

OPERATING INSTRUCTIONS  
FOR  
TYPE 675-M  
PIEZO-ELECTRIC OSCILLATOR  
FORM 384-B



**GENERAL RADIO COMPANY**  
CAMBRIDGE A, MASSACHUSETTS



# GENERAL RADIO COMPANY

---

## PATENT NOTICE

The Type 675-M Piezo-Electric Oscillator is manufactured and sold under the following United States Letters Patent owned by the General Radio Company or by license grants from other companies:

|           |           |
|-----------|-----------|
| 1,542,995 | 1,951,530 |
| 1,713,146 | 1,943,302 |
| 1,744,675 | 1,955,739 |
| 1,967,185 |           |

and all patents and patent applications of Dr. G. W. Pierce pertaining to piezo-electric crystals and their associated circuits.

This instrument is licensed under patents of the American Telephone and Telegraph Company solely for utilization in research, investigation, measurement, testing, instruction, and development work in pure and applied science.





# GENERAL RADIO COMPANY

---

## OPERATING INSTRUCTIONS FOR TYPE 675-M PIEZO-ELECTRIC OSCILLATOR

### PART 1 DESCRIPTION

**PURPOSE** The Type 675-M Piezo-Electric Oscillator is a secondary frequency standard of high accuracy intended for use primarily in the laboratory. It is intended for use only with Type 676-A (50-kc) and Type 476-A (100 kc) Quartz Bars. Successful operation cannot be obtained with any other type of quartz crystal.

**PRINCIPLE OF OPERATION** The crystal oscillator circuit was developed particularly for use in frequency standards. It is one in which the crystal is operated at, or very near, its true resonant frequency. The entire oscillator circuit has been designed to insure maximum stability. Voltage compensation is employed to reduce to entirely negligible values the small changes in frequency caused by line voltage variations.

The crystal is connected in series with an inductor and the combination acts as the inductance of a Colpitts oscillator. The condensers of the oscillator are mounted with the crystal and coil in the temperature-control unit. In this way, all of the principal frequency-determining elements of the system are held under similar and constant conditions.

Figure 1, page 5, is a complete circuit diagram.

**FREQUENCY ADJUSTMENT** A small variable condenser, placed in parallel with one section of the main oscillator condenser, provides for regulation of the oscillator frequency over a narrow range to adjust the standard into agreement with standard frequency transmissions or any other standard of comparison.

A small condenser (the value of which is adjustable by a screw driver adjustment) may be cut into the circuit by operating a push-button on the panel, causing a fre-

quency reduction of roughly 8 parts per million while the button is pressed. This change may be used in frequency measurements to determine the sign of a beat difference, that is, whether an unknown frequency lies above or below the standard frequency.

**OUTPUT** Two output amplifiers are provided, one for the crystal fundamental frequency for use in controlling multivibrators and the other for harmonics of the crystal frequency for use in frequency measurements.

**TEMPERATURE CONTROL** Room is provided in the temperature-controlled space for mounting a Type 476-A Quartz Bar on a Type 476-Pl Base, or for mounting a Type 676-A Quartz Bar and circuit. Within the metal case are placed a balsa wood insulating wall, distributed heaters (placed on all six faces of the interior assembly), a cast aluminum distributing layer, an asbestos attenuating layer, and a second heavy cast aluminum distributing layer which forms the wall of the temperature-controlled space. A thermometer is mounted behind a removable cover plate on the panel and is illuminated by the heat control signal lamp. The thermometer indicates the air temperature of the inner space. The temperature control system is completely a-c operated.

**POWER SUPPLY** The Type 675-M Piezo-Electric Oscillator is designed for complete a-c operation from 115-volt 50-60 cycle supply. The internal power supply provides for three filament circuits at 6 volts and for 50 milliamperes at 180 volts for external equipment, such as multivibrators, operated with the oscillator.

# GENERAL RADIO COMPANY

## PART 2 INSTALLATION

**MOUNTING** In general, the unit should be mounted to be as free from vibration as possible, if the best performance is to be realized. Ordinary vibration, such as that caused by traffic, will cause no difficulty. The oscillator is preferably installed in a relay rack, properly grounded.

**QUARTZ BAR** Install the quartz bar inside the temperature-controlled space (if not shipped in place) and connect the leads to the terminals on the mounting base.

**THERMOSTAT AND THERMOMETER** Place the thermostat in the mounting block on the rear face of the aluminum temperature-control box. Connect the leads to the terminals on the block just above the thermostat mounting. If shipped in place, check the connections. Install the thermometer in its mounting behind the removable cover plate on the panel.

**VACUUM TUBES:** Install tubes as follows:

| <u>Type</u> | <u>Location</u>                |
|-------------|--------------------------------|
| 77          | Top Shelf                      |
| 76          | 5-Prong sockets on lower shelf |
| 83          | 4-Prong socket on lower shelf  |

Be sure the clip is connected to the grid terminal at the top of the 77 tube. If only one amplifier is desired, the other amplifier tube may be omitted. Looking at the rear of the unit, the left-hand five-prong socket is the one for the linear, or "control output" amplifier while the right-hand five-prong socket is for the "harmonic" amplifier. The terminal connections for the desired output are shown on the wiring diagram.

**POWER SUPPLY** Connect the oscillator to the 115-volt, 50- to 60-cycle mains by means of the cord and plug combination applied.

**OUTPUT CONNECTIONS** The output connections are made by means of the small multipoint connector at the rear of the instrument. For further details, see the circuit diagram. Impedance of control output, 10,000 ohms approximately; of harmonic output, 65 ohms approximately.

**POWER SUPPLY FOR EXTERNAL EQUIPMENT** Three 6-volt filament circuits and also plate supply at 180 volts are available at the large multipoint connector at the rear. See the circuit diagram for connections.

## PART 3 OPERATION

Having placed the unit in operating condition as described above, throw the HEAT ON-OFF switch to ON. The heat indicator bull's-eye should light immediately.

To test the operation of the heat-control circuit, short circuit the thermostat temporarily. The relay should open and the heat indicator lamp go out.

The heat will remain on for about one-half hour, before the thermostat begins to operate. After about one hour the thermostat will operate so that the heat is on (indicator lamp lighted) about 20 seconds and off (indicator lamp out) about 95 seconds at ordinary room temperatures. A period of about four hours is required before the inner temperature reaches its final value.

A fusible link is provided which melts and opens the heater circuit if the temperature becomes excessively high, due to relay or thermostat failure.

**CAUTION** When first starting up the temperature-control system, particularly if the instrument is very cold, turn on the heat for 15 minutes, then turn it off for five minutes, and so on, until the thermostat begins to operate. If desired, the balsa wood cover may be removed and the heat left on. When the thermostat begins to operate, replace the balsa wood cover.

These precautions are necessary because the heat remains on long enough to raise the air temperature to a point which will melt the fusible link, before enough heat has been absorbed by the unit to cause the thermostat to operate.

It is recommended that the temperature control be operated continuously, unless the equipment is to be shut down for an extended period.

Throw the POWER SUPPLY ON-OFF switch to ON; adjust the supply voltage control



# GENERAL RADIO COMPANY

until a filament voltage of 6 volts is indicated on the filament voltmeter. The plate voltmeter will indicate about 200 volts until the tubes begin to draw plate current, after which the voltage will drop somewhat. The crystal oscillator plate current meter will read about one milliampere when the crystal is not oscillating, dropping to 0.3 to 0.7 milliampere (depending on type of crystal) with the crystal

oscillating. Adjust the crystal oscillator TUNING dial to the setting given in the calibration certificate, or, if no certificate is given, set to 50 divisions. When checked against standard frequency transmissions, or other frequency standard, the dial should be adjusted to bring the frequency into agreement with the comparison standard.

## PART 4 SPECIFICATIONS

**FREQUENCY RANGE** The instrument is designed only for 50-kc operation, with a Type 676-A Quartz Bar, or 100 kc with a Type 476-A Quartz Bar. Other frequencies can be supplied only on special order.

**ACCURACY** The absolute guaranteed accuracy is 20 parts per million (0.002%). The frequency stability is 1 part per million (0.0001%) over long periods of time.

**QUARTZ BAR** Not furnished with the instrument, which is intended for use only with Type 676-A (50-kc) or Type 476-A (100 kc) Quartz Bars. Other crystal frequencies between these values may be obtained on special order.

**ACCURACY OF TEMPERATURE CONTROL** The unit will control the temperature of the inner space to within  $+0.1^{\circ}\text{C}$  for room temperature changes of  $\pm 20^{\circ}\text{C}$  from normal of  $25^{\circ}\text{C}$ .

**OPERATING TEMPERATURE** Normally  $60^{\circ}\text{C}$ , but thermostats for other temperatures can be supplied if ordered.

**THERMOSTAT** Fixed, or non-adjustable, mercury type. Accuracy of working point  $\pm 0.1^{\circ}\text{C}$ . Sensitivity,  $0.05^{\circ}\text{C}$ .

**OUTPUT AMPLIFIERS** Two output amplifiers are provided, one to pass the crystal oscillator fundamental frequency (for control of multivibrators) and the other to emphasize harmonics of the crystal frequency (for measurement purposes). Either, or both, may be used as desired. Impedance of control amplifier, 10,000 ohms, approximately; of harmonic amplifier, 65 ohms approximately.

**POWER SUPPLY** 105-125 volts, 50-60 cycles. Provision is made through a multipoint connector for obtaining three filament circuits at 6 volts, and 50 milliamperes at 180 volts, for supplying up to three Type 692-B Multivibrators, or two Type 692-B Multivibrators and one Type 693-B Syncro-Clock and Amplifier.

**POWER CONSUMPTION** 45 watts, heaters off; 120 watts, heaters on, with no external units connected to power supply.

**CONTROLS** Power supply ON-OFF switch; HEAT ON-OFF switch;  $\Delta f$  switch (push button). Line input voltage control. Crystal oscillator tuning condenser.

**METERS** Filament voltage; plate voltage; crystal oscillator plate current.

**ACCESSORIES SUPPLIED WITH INSTRUMENT** See packing list.

**ADDITIONAL ACCESSORIES REQUIRED** Quartz bar, Type 676-A or Type 476-A.

**TUBES**  
1 - Type 77 Crystal Oscillator  
2 - Type 76 Amplifiers  
1 - Type 83 Rectifier

**MOUNTING** Standard 19-inch relay rack mounting. Unit fitted with dust cover. Can be supplied in walnut cabinet on special order.

**DIMENSIONS** Panel (width) 19 x (height) 17-1/2 x (depth) 12 inches over-all.

**NET WEIGHT** 63 pounds.

# GENERAL RADIO COMPANY

## PARTS LIST

### Resistors

|                    |                     |
|--------------------|---------------------|
| A = 1 M $\Omega$   | R-1 = 2500 $\Omega$ |
| B = 40 k $\Omega$  | R-2 = 1500 $\Omega$ |
| C = 0.1 M $\Omega$ | R-3 = 10 k $\Omega$ |
| D = 20 k $\Omega$  | R-4 = 700 $\Omega$  |
| E = 10 k $\Omega$  | R-5 = 18 $\Omega$   |
| F = 20 k $\Omega$  | R-6 = 5 k $\Omega$  |
| G = 50 k $\Omega$  | R-7 = 150 $\Omega$  |
| H = 1 M $\Omega$   |                     |
| J = 30 k $\Omega$  |                     |

### Condensers

|                      |                      |
|----------------------|----------------------|
| C-1 = 100 $\mu$ f    | C-11 = 1.0 $\mu$ f   |
| C-2 = 10-70 $\mu$ f  | C-12 = 1.0 $\mu$ f   |
| C-3 = 0.001 $\mu$ f  | C-13 = 1.0 $\mu$ f   |
| C-4 = 0.01 $\mu$ f   | C-14 = 1.0 $\mu$ f   |
| C-5 = 0.025 $\mu$ f  | C-15 = 0.01 $\mu$ f  |
| C-6 = 0.025 $\mu$ f  | C-16 = 0.25 $\mu$ f  |
| C-7 = 0.0001 $\mu$ f | C-17 = 0.002 $\mu$ f |
| C-8 = 0.002 $\mu$ f  | C-18 = 0.01 $\mu$ f  |
| C-9 = 0.0001 $\mu$ f | C-19 = 0.01 $\mu$ f  |
| C-10 = 0.005 $\mu$ f |                      |

### Switches

|                              |
|------------------------------|
| S-1 = Heat Switch            |
| S-2 = Heat Switch            |
| S-3 = Power Switch           |
| S-4 = Relay                  |
| S-5 = Thermostat             |
| S-6 = $\Delta$ f Push Button |

### Tubes

|                    |
|--------------------|
| T-1 = Radiotron 77 |
| T-2 = " 76         |
| T-3 = " 76         |
| T-4 = " 83         |

### Inductor

L-1 = 8 mh

The circuit elements shown within the dotted area in wiring diagram comprise a Type 476-A or a Type 676-A Quartz Bar and Mounting.

## PACKING LIST

### VACUUM TUBES:

- 1 - Radiotron Type 77
- 2 - Radiotron Type 76
- 1 - Radiotron Type 83

### MISCELLANEOUS:

- 1 - Thermostat
- 1 - Thermometer
- 1 - Attachment Cord and Plug
- 2 - Multipoint Connectors

### SPARE PARTS:

- 5 - 1/10-amp. fuses
- 5 - 1-1/2-amp. fuses
- 2 - Pilot lamps (2.5 volts for heat indicator)
- 2 - Pilot lamps (6 volts)
- 2 - Fusible links

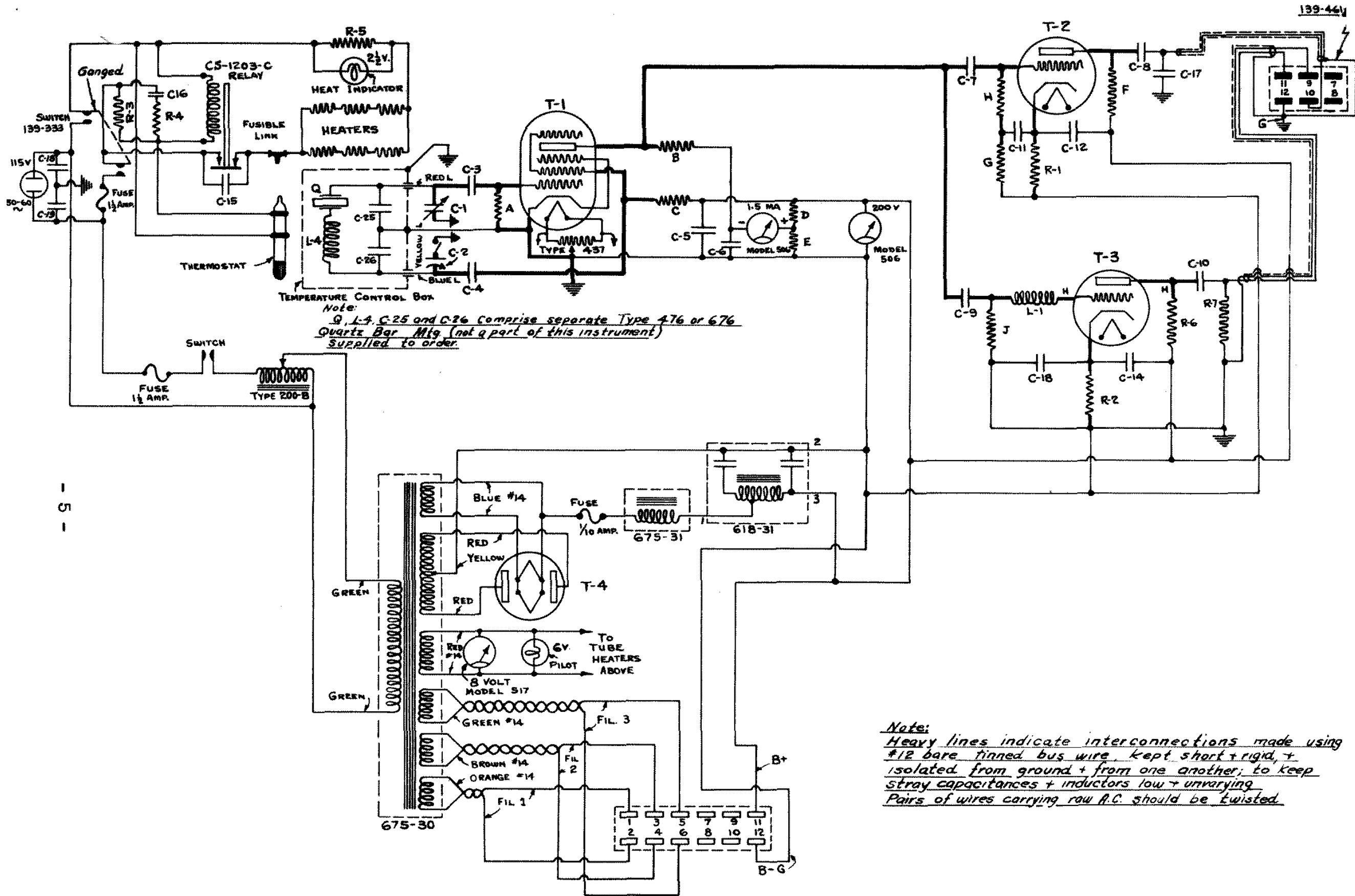

Figure 1. Circuit Diagram for Type 675-M Piezo-Electric Oscillator.

GENERAL RADIO COMPANY



