

BULLETIN 926

GENERAL RADIO

QUALITY APPARATUS



TRADE MARK

Manufactured by the
GENERAL RADIO CO
Cambridge, Mass. U.S.A.



PRINTED IN U.S.A.



File Courtesy of GRWiki.org



THE GENERAL RADIO COMPANY was incorporated in 1915 for the purpose of developing and manufacturing radio apparatus for use in laboratory experimental work and in radio transmission and reception.

Since 1915 the General Radio Company has done much in scientific research and development work to promote the present-day efficiency of broadcast reception.

Low loss condenser design has received much attention, and the General Radio Company was the first in this country to supply such condensers commercially. It was also the first company to supply closed core audio frequency amplifying transformers, and has been foremost in supplying audio frequency transformers to accompany the great improvements in broadcasting station quality of transmission and improved loud speaker reproduction.

The products of the General Radio Company include not only those listed in this catalog, but also radio and electrical laboratory apparatus.

Information and bulletins of special apparatus will be sent on request.

These instruments include:

Oscillograph	Galvanometer Shunt
Decade Condensers	Impedance Bridge
Precision Condensers	Capacity Bridge
Variometers	Audibility Meter
Standards of Inductance	Ratio Arm Box
Wavemeters	Hot Wire Ammeters

Low Loss Variable Air Condensers

Decade Resistance Boxes

Standards of Resistance

Recorders

Miscellaneous Apparatus

The instruments manufactured by the General Radio Company are the result of careful engineering design. In many cases they represent the result of years of development work and investigation in the General Radio laboratories.

It has been the aim of this company to contribute only quality instruments to the radio and electrical industry.

Every instrument is guaranteed.

This bulletin replaces Bulletin No. 925.



FOREWORD

N buying radio apparatus it is always well to remember that Radio is a Science depending upon definite electrical principles.

It, therefore, requires instruments that are scientifically correct — mechanically and electrically.

The radio apparatus described in this catalog has been developed by experienced radio engineers after extensive research and careful study of actual operating conditions. This development work has been conducted in the well-equipped electrical laboratories of the General Radio Company.

All General Radio parts are constructed to meet the most exacting requirements of radio broadcast reception, and are of the same high standard of materials and workmanship as the radio laboratory instruments manufactured by the General Radio Company.

The prices listed in this catalog are as low as the highest quality of materials, workmanship, and manufacturing methods permit. Prices are revised and correct to October, 1926, subject to change without notice.

The General Radio Company has endeavored to make it possible for the experimenter to obtain its products with a minimum of effort. A careful selection of distributors and dealers has been made. They are best fitted to serve you. If, however, you are unable to obtain our products in your particular locality they will be delivered to you, postpaid, direct from the factory upon receipt of list price.

When ordering by telegraph specify quantity and our code word.

Unless otherwise instructed we shall use our own judgment regarding method of shipment.

GENERAL RADIO CO.

30 State Street

Cambridge, 39, Mass.





**TYPE 400
POWER AMPLIFIER AND PLATE SUPPLY**

The Type 400 Power Amplifier and Plate Supply is designed to operate on 110 volt (60 cycle) A. C. and provides voltages of 45, 90, and 130 for the receiver in addition to supplying the proper plate voltage and grid bias for the power amplifier.

It is designed for use with all popular makes and circuits of radio receivers regardless of whether they may be operated by storage battery or dry cell tubes.

The Power Amplifier in conjunction with the plate supply permits the convenient use of a high power tube in the last amplifier stage.

This overcomes the tendency toward tube overloading and removes the most common cause of distortion in loudspeaker operation.

An outstanding feature of the Type 400 unit is that it has no variable resistance voltage controls to get out of order and cause noisy reception. Voltages in this unit are controlled by fixed resistances, which are tightly sealed from dust and moisture.

Once installed it requires no further attention and is ready for years of unfailing service.

The Type 400 unit uses the Rectron UX-213 rectifier tube and the UX-171 power tube in the amplifier.

Voltage drops at the various taps per milliamper load are as follows:

Tap	Open circuit	Rate of drop per milliamper
45	50	2.35
90	118	3.57
130	179	2.92

Type 400 Power Amplifier and Plate Supply, without tubes.....\$68.00

Dimensions 15¼" x 7" x 7". Weight 18¼ lbs.

Code Word: "ANNUL."





Type 405

**TYPE 405
PLATE SUPPLY**

The Type 405 Plate Supply is similar in general appearance and construction to the Type 400 except that it does not have the power amplifier feature. It is a thoroughly dependable source of plate voltage operating from 110 volt (60 cycle) A. C. The new Raytheon type BH tube is used as a rectifier. Voltages, as in the Type 400 unit, are readily adaptable to all popular makes and circuits of receivers by means of fixed resistances, thus eliminating bothersome

and noisy tendencies of variable resistance voltage controls.

The Type 405 unit has four positive plate voltage taps, providing voltages of 45, 90, 130 and 200.

The voltage drops at the various taps per milliamper load are as follows:

Tap	Open	Rate of drop per milliamper
45	55	2.35 volts
90	132	3.50 volts
130	205	3.10 volts
200	260	1.80 volts

Type 405 Plate Supply, with BH Raytheon Tube.....\$46.00

Dimensions 9½" x 7" x 6". Weight 13 lbs.

Code Word: "ANODE."

TYPE BH RAYTHEON TUBE

The Raytheon tube possesses characteristics which make it particularly well suited to use in the plate supply circuit. Unlike the thermionic tubes, the Raytheon tube has no filament. This feature not only removes a possibility of accidental damage to the tube, but also eliminates the limiting factor of the ordinary type of tube's life. It will supply enough current for multi-tube sets, its maximum output being 80 milliamperes.

Another feature of this tube is that by the inclusion of two anodes, double wave rectification is secured in one tube. This results not only in a great increase in the efficiency of the device, but also reduces the amount of hum in the output.

Type BH Raytheon Rectifier Tube.....\$6.00

Code Word: "RAYTHEON."



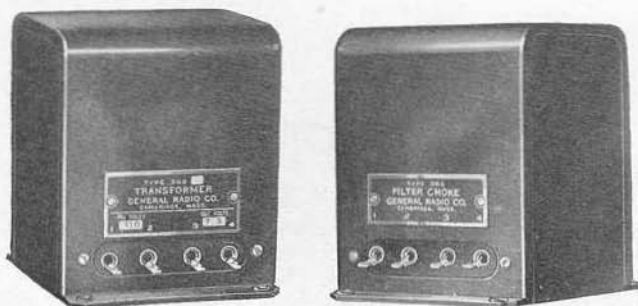

Type 365

RECTIFIER TRANSFORMER

With the development of satisfactory and reliable rectifying devices there has arisen a demand for a suitable transformer for use in plate supply units. The Type 365 Transformer has been developed especially for this use and has a wide range of applicability to various rectifying devices.

The primary is designed for a 110-volt 60-cycle circuit. The high voltage secondary consists of two sections of 275 volts each. There is also a 7.5 volt secondary. This combination of windings makes the Type 365 Transformer adapted to either single or double wave rectifiers. The low-voltage winding may be used to light the filament of a thermionic rectifier, or in case the Raytheon tube is used as a rectifier it may be used as a filament supply for a power amplifier. It is possible to operate one stage of power amplification with unrectified filament supply.

The 365 Transformer is mounted in a black japanned metal case which provides both complete shielding and an attractive assembly.

Type 365 Rectifier Transformer.....\$8.00

Dimensions 4¼" x 3⅝" x 4½". Weight 4½ lbs.

Code Word: "TENOR."

Type 366

FILTER CHOKE

In conjunction with rectifiers used in plate supply units some form of filter is necessary in order to eliminate the hum in the rectifier output. The Type 366 Filter Choke is designed to meet this need. It is actually two chokes assembled in one case. The resistance is low, reducing the voltage lost in the chokes to a minimum. Four terminals are brought out to the panel, so that the chokes may be connected in any type of filter system the constructor may desire.

The Type 366 Filter Choke is mounted in the same type and size of case as the 365 Transformer.

Type 366 Filter Choke.....\$8.00

Dimensions 4¼" x 3⅝" x 4½". Weight 4¾ lbs.

Code Word: "TEPID."

In addition to the rectifier transformer, filter choke, socket, and tube several fixed condensers are used in the plate supply circuit. We are prepared to supply these condensers at the following prices:

0.1 M F., \$0.70; 1 M F., \$1.25; 2 M F., \$1.75; 4 M F., \$3.50

Clarostat Resistances for voltage control.....\$2.25



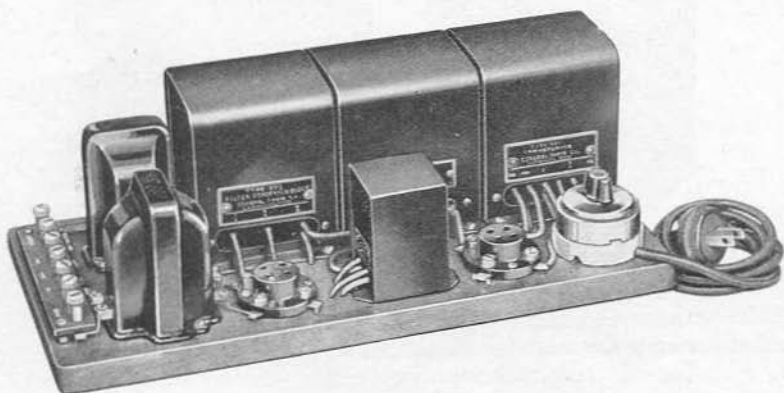

Type 390

RECTRON POWER AMPLIFIER AND PLATE SUPPLY KIT

The above illustration shows the Type 390 Rectron Plate Supply and Power Amplifier kit fully assembled and ready for operation.

This unit is supplied in knocked down form similar to the Type 395 Raytheon unit shown on the opposite page.

The kit contains all parts necessary to the construction of a Power Amplifier and Plate Supply using the UX-213 Rectron Rectifier tube and UX-171 Power Tube in the amplifier and includes a drilled baseboard, cord with wall plug, switch, binding post strip, binding posts, and all screws and nuts. In characteristics and performance it is exactly the same as the complete Type 400 unit described on page 9231.

The assembled unit operates from 110 volt (60 cycle) A. C. and provides voltages of 45 and 90, for the receiver and supplies a plate voltage of 180 direct to the power tube together with the necessary grid bias for this tube.

Type 390 Rectron Kit, without tubes.....\$47.50

Dimensions 15" x 7½" x 4¾". Weight 17½ lbs.

Code Word: "ANVIL."





Type 395

RAYTHEON POWER AMPLIFIER AND PLATE SUPPLY KIT

This unit is supplied in knocked down form as shown above, and when assembled is similar in appearance to the unit described on the previous page.

The Type 395 kit is designed to use the new Type BH Raytheon tube as a rectifier and provides voltages of 45 and 90 for the receiver and 180 for the plate of the UX-171 power tube of the amplifier together with the necessary grid bias for this tube.

It operates from 110 volt (60 cycle) A. C. and is readily adaptable to all popular radio receiver circuits.

Voltages are adjusted by means of fixed resistances which are tightly sealed from dust and moisture.

This unit may be easily assembled and operated by the most inexperienced amateur builder in a single evening. Baseboard is supplied all drilled so that the instrument may be readily mounted and wired. The kit consists of a Type 365 Rectifier Transformer, Type 366 Filter Choke, all necessary by-pass condensers, resistances, a cord with wall plug, switch, binding posts and screws and nuts.

Type 395 Raytheon Kit, without tubes.....\$50.00

Dimensions 15" x 7½" x 4¾". Weight 17 lbs.

Code Word: "APART."





Type 285
1 to 6 ratio
Type 285-L
1 to 2 ratio
Type 285-D
1 to 3 ratio

**TYPE 285
AUDIO AMPLIFYING
TRANSFORMERS**

In order to improve both the upper and lower ends of the amplification curve, transformers must be designed in such a way that they will not have a high distributed capacity, but at the same time will have high inductance values.

This has been accomplished in the new Type 285 transformers by using a larger core of a very high quality of selected steel and properly adjusting the coil turns.

In some instances a single stage of amplification using the 1:6 ratio transformer is satisfactory. Where additional amplification is required a second transformer having a lower ratio, 1 to 2, is provided. In many cases, particularly in the vicinity of broadcasting stations, two 1 to 2 ratio transformers are sufficient. This combination gives an intense volume with amazing purity of tone.

Type 285 Amplifying Transformer, 1 to 6 ratio.....\$6.00
Code Word: "TOKEN."

Type 285L Amplifying Transformer, 1 to 2 ratio.....\$6.00
Code Word: "TOPAZ."

The new General Radio Type 285-D has been designed specifically for use in the first stage of audio amplification following the new 200A detector tube. It produces very noticeably better tone quality than is possible with other transformers having a lower input impedance.

The transformer, however, gives excellent results with other tubes in either the first or second stage of amplification, but is particularly recommended for the UX-200A. It has a turns ratio of 1:3.

Type 285-D Audio Transformer..... Price \$6.00
Code Word: "TOTEM."

Dimensions 3½" x 3¼" x 2½". Weight 1½ lbs.





TYPE 369 COUPLING IMPEDANCE

Many experimenters are now engaged in a search for a perfect amplifier. While the greater efficiency of the transformer coupled amplifier counts heavily in its favor, somewhat better quality can be obtained by the use of other methods of coupling if one is willing to dispense with the gain in amplification due to the transformer.

The impedance method of coupling has much in its favor as compared to the use of resistances.

By using a choke of sufficiently high inductance, a quality of reproduction may be obtained which could not be distinguished from that obtained by the use of resistance, and a larger amplification per stage secured. The use of chokes has the added advantage that less plate voltage is required.

Those who are familiar with the use of resistance or impedance coupled amplifiers will find in the Type 369 a coupling impedance that will give them a combination of amplification and quality they have long been waiting for.

The Type 369 Coupling Impedance is mounted in a black japanned metal case, identical in size and appearance with the Type 285 Transformers.

Type 369 Coupling Impedance.....\$5.00

Dimensions 3½" x 3¼" x 2½". Weight 1½ lbs.

Code Word: "TONIC."





Type 387

SPEAKER FILTER



The Type 387 Speaker Filter is designed to adjust the impedance of all standard amplifier tubes to the cone type Western Electric and other similar speakers, thus producing a very noticeable improvement in quality of reproduction.

The action of most loudspeakers is affected by plate currents of more than a few milliamperes and the function of the filter is to protect the speaker windings from the direct current while allowing an unimpeded flow of alternating frequency current.

The 387 is capable of covering a very wide frequency range so that no distortion is introduced and may be used in an impedance range of from 3,000 to 25,000 ohms. In installing the Type 387 it is simply necessary to connect the filter primary to the output of the amplifier and the secondary to the speaker unit.

Type 387 Speaker Filter.....Price \$6.00

Dimensions 3½" x 4" x 4⅛". Weight 3 lbs.

Code Word: "TOWEL."

Type 367

OUTPUT TRANSFORMER

This transformer is similar in appearance to the Type 285 Amplifying Transformer and is particularly adapted to use between the UX-112 tube and a Western Electric or similar cone type loudspeaker. It serves to adapt the output impedance of the amplifier tube to the input of the speaker, with the result that very marked improvement in tone quality is produced. In connecting this instrument in the circuit it is simply necessary to connect the primary to the amplifier output and the secondary to the speaker input.

Type 367 Output Transformer.....Price \$5.00

Dimensions 3½" x 3¾" x 2½". Weight 2½ lbs.

Code Word: "TESTY."





Type 271

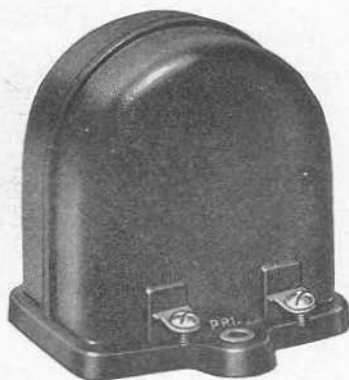

Type 331

MEDIUM FREQUENCY TRANSFORMERS

The 271 Transformer has been designed to meet the specific requirements of a medium frequency transformer for use in long wave reception. The working range is from 7000 to 12,000 meters with a peak frequency of 10,000 meters.

The transformer is shielded both electrostatically and electromagnetically, making it possible to use several of these transformers in cascade with a separation as small as one inch.

The whole unit is enclosed in an attractively japanned metal case fitted with convenient mounting holes and terminal posts with binding screws.

Type 271 Medium Frequency Transformer.....\$5.00

Dimensions $2\frac{1}{2}'' \times 2\frac{1}{4}'' \times 1\frac{1}{2}''$. Weight 6 oz.

Code Word: "TULIP."

Type 331

TUNED TRANSFORMER

In some circuits amplification at the peak frequency of the medium frequency transformers is desirable. In order that this amplification may be over as narrow a band as it is practical to work, a tuned or filter transformer should be used in the output stage. The Type 331 Tuned Transformer provides the necessary tuning to enable the Type 271 Transformers to be used at their peak frequency. An excellent combination for 30 K. C. amplification is three Type 271 Transformers and one Type 331.

The Type 331 Transformer has an air core and has close coupling between the primary and secondary winding. The fixed tuning condenser is mounted inside of the attractive moulded bakelite case that encloses the unit. The mounting holes are the same as those of the Type 271 Transformer.

Type 331 Tuned (30 K. C.) Transformer.....\$5.00

Dimensions $2\frac{3}{4}'' \times 2\frac{3}{4}'' \times 2\frac{1}{2}''$. Weight 8 oz.

Code Word: "TABLE."





TYPE 268 VARIO COUPLER

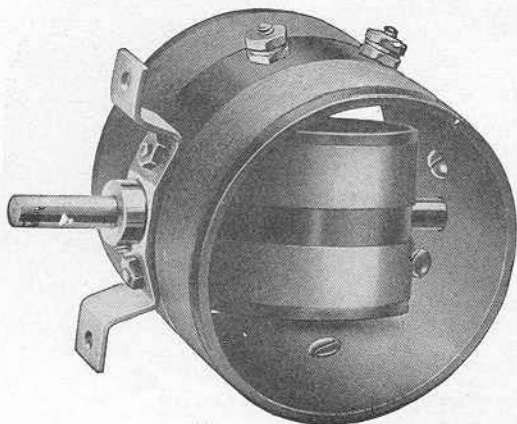

The Type 268 Vario-coupler covers the band of wavelengths from 60 to 600 meters, which includes practically all popular radio broadcast reception. This instrument is especially compact and very efficient in circuits which require a high grade coupler.

Both the rotor and stator forms are of genuine moulded bakelite and are wound with green silk covered wire. The metal parts are of nickel finish.

The bearings are exceptionally accurate and smooth running so as to insure uniform operation over long periods of use.

Mounting to panel is by means of a convenient and rugged mounting bracket. Necessary screws and nuts are provided with each instrument.

Type 268 Variocoupler.....\$2.75

Dimensions 4" x 4" x 2½". Weight 6 oz.

Code Word: "VALET."

TYPE 269 VARIOMETER

The outstanding features of the Type 269 Variometer are its size and its efficiency of operation.

It is much smaller than the average variometer which gives it a decided advantage where compactness and portability of the set are considerations. It is equally efficient mechanically and electrically and has a maximum to minimum inductance range of 660 to 60 microhenries.

The stator and rotor forms are of genuine moulded bakelite, wound with green silk covered wire. Terminals are very accessible, and a soldering lug is provided for using the instrument in circuits requiring split variometer connections. The bearings are accurate and very smooth running.

All metal parts are brass with nickel finish. Panel installation is made easy by a convenient mounting bracket.

Type 269 Variometer...\$5.00

Dimensions 4¾"x3"x1¾".

Weight 7 oz.

Code Word: "VALID."

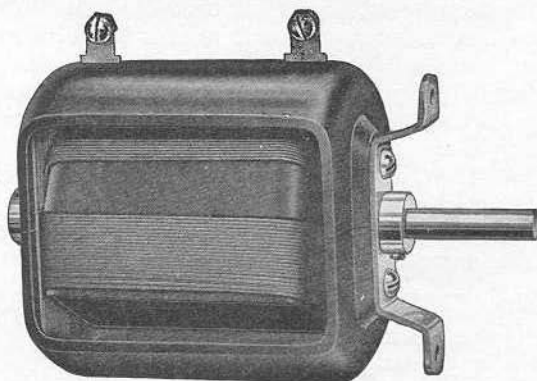

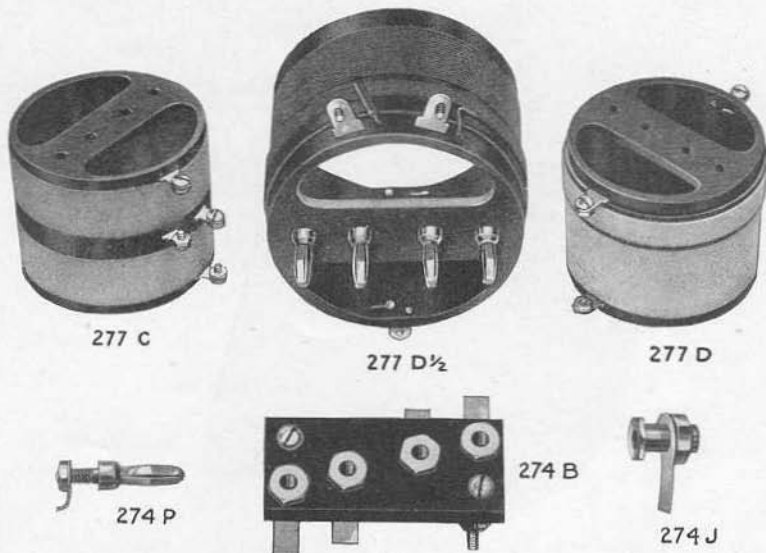

INDUCTANCE AND COUPLING COILS

The Type 277 Coils are so shaped in ratio of diameter to length, the material so chosen, and the construction such that they have very low losses.

Models A, B, and C have single windings and are wound in two sections so that the mid point may be obtained or coupling turns added at the center point. Models D, D $\frac{1}{2}$, and D $\frac{1}{4}$ are coupling coils with a small primary winding.

The inductances of the 277-A, B, and C coils and of the large windings of the 277-D $\frac{1}{4}$, D $\frac{1}{2}$, and D coils are .014, .055, and .217 milli-henries respectively. When used with 500 M M F. condensers these coils have wavelength ranges of 50-150, 100-300, and 200-600 meters respectively.

Mounting holes are arranged so that Type 274-P Plugs may be inserted and coils may be used interchangeably in the coil mounting bases.

Type	Wavelength	Code Word	Price
277-A	50 to 150 meters	VALOR	\$1.25
277-B	100 to 300 meters	VAPID	1.25
277-C	200 to 600 meters	VENUS	1.25
277-E	300 to 900 meters	VIRUS	1.50
277-D	Coupling Coil, 200 to 600 meters	VIGIL	1.50
277-D $\frac{1}{2}$	Coupling Coil, 100 to 300 meters	VIPER	1.50
277-D $\frac{1}{4}$	Coupling Coil, 50 to 150 meters	VILLA	1.50
277-U	Unwound Coil Form	VIGOR	.75

Dimensions 3 $\frac{1}{2}$ " x 2 $\frac{1}{4}$ ". Weight 5 oz.

Coil Mounting Accessories

274-A	Base with 3 jacks.....	\$0.90
274-B	Base with 4 jacks.....	1.00
274-C	Base with 2 jacks.....	.75
274-P	Contact Plug.....	ea. .10
274-J	Jacks.....	ea. .10



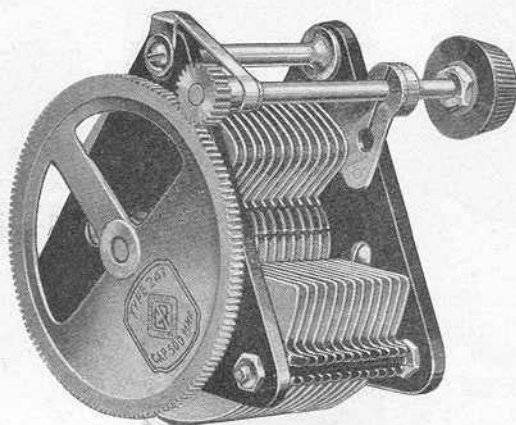

TYPE 247-H
VARIABLE CONDENSER
with Vernier Gear

The tuning of radio circuits can best be accomplished both from a range and simplicity viewpoint by the use of variable condensers. Because of this, much attention has been given to their design with the result that today high quality condensers are available at very moderate prices.

The General Radio Company has been very closely associated with condenser development and has contributed much to the science of radio in condenser design. In 1915 it supplied the first low loss type of condenser.

During the war General Radio condensers were used by the U. S. government in connection with superheterodyne and other circuit developments. In 1922 the present low loss soldered type was introduced.

- Type 247-H, 500 M M F. Panel mounting, with gear.....\$5.00
Dimensions 4" x 4" x 4 $\frac{1}{8}$ ". Weight 1 $\frac{1}{8}$ lbs.
Code Word: "COMIC."
- Type 247-P, 350 M M F. Panel mounting, with gear.....\$4.75
Dimensions 4" x 4" x 4 $\frac{1}{8}$ ". Weight 1 lb.
Code Word: "ABBEY."
- Type 247-M, 250 M M F. Panel mounting, with gear.....\$4.50
Dimensions 4" x 4" x 4". Weight $\frac{7}{8}$ lb.
Code Word: "CIGAR."



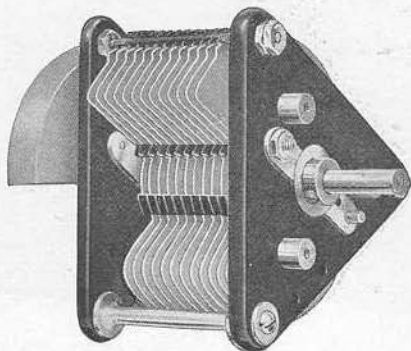

Type 247-F
VARIABLE CONDENSER
With Counterweight

In the soldered plate type, the rotors and stators are each soldered in specially constructed jigs which permit only flat plates to be used and keep the plates uniformly spaced. This method of assembly not only insures accurate spacing but a low resistance and a permanent contact between plates. It also makes the entire assembly very rigid.

To secure smoothness in operation and uniformity of turning torque all rotors are carefully counter balanced. Where slow motion is desired to secure fine settings the condensers are equipped with a gear and pinion.

There are two general types of design, the insulated (hard rubber) end plate and the metal (aluminum) and plate type described on page 9246. The overall losses are essentially the same and the installation conditions will determine which type should be used. The Type 247 condensers are the hard rubber end plate type while the 334 and 374 series have metal end plates which are grounded to the condenser rotors.

- Type 247-F, 500 M M F. Panel mounting, without gear.....\$4.00
Dimensions 4" x 4" x 4 $\frac{1}{8}$ ". Weight 1 lb.
Code Word: "COCOA."
- Type 247-N, 350 M M F. Panel mounting, without gear.....\$3.75
Dimensions 4" x 4" x 4 $\frac{1}{8}$ ". Weight $\frac{7}{8}$ lb.
Code Word: "ABASE."
- Type 247-K, 250 M M F. Panel mounting, without gear.....\$3.50
Dimensions 4" x 4" x 4". Weight $\frac{7}{8}$ lb.
Code Word: "CARGO."



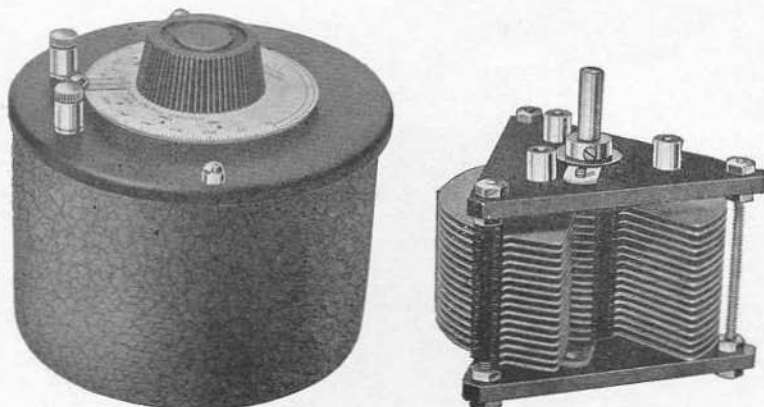

Type 247

MOUNTED VARIABLE CONDENSER

Experimental radio receiving sets require condensers capable of extreme accuracy in capacity variation. The Types 247-E, G, J, and L Condensers definitely meet this demand. They are mounted in a metal case finished with a black crystalline finish, the same as is used on expensive laboratory instruments. This case is grounded to the rotor plates, thus shielding the condenser and eliminating many of the disturbing effects due to bringing the hand near the condenser.

The minimum capacity of these condensers is approximately 20 micromicrofarads. This low value makes a wide range of wavelengths possible when the proper coils are used.

In addition to the regular degree graduations of the etched metal dial, this dial is marked with a scale to show capacity measurements in micromicrofarads. This is a unique and valuable feature for radio receiving condensers, and it enables the operator to know at all times just what capacity he is using.

- Type 247-E, 500 M M F. mounted, without gear.....\$6.25
Dimensions 5" x 5" x 4½". Weight 2 lbs.
Code Word: "COUPE."
- Type 247-G, 500 M M F. mounted, with gear.....\$7.25
Dimensions 5" x 5" x 5⅛". Weight 2¼ lbs.
Code Word: "COLIC."
- Type 247-J, 250 M M F. mounted, without gear.....\$5.75
Dimensions 5" x 5" x 4½". Weight 1¾ lbs.
Code Word: "CANON."
- Type 247-L, 250 M M F. mounted, with gear.....\$7.00
Dimensions 5" x 5" x 4½". Weight 1¾ lbs.
Code Word: "CAROM."



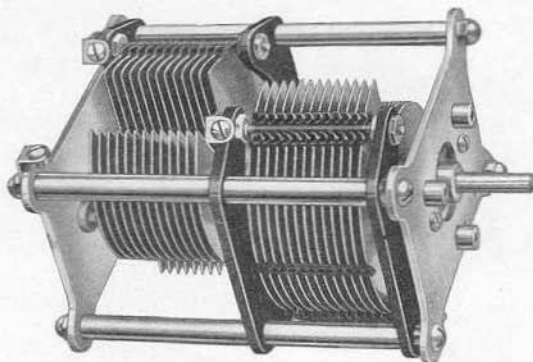

Type 374-F

STRAIGHTLINE FREQUENCY CONDENSER

Grounded Rotor Type

With the increasing use of frequency instead of wavelength for dial settings, there has come a demand for a straight line frequency condenser. Such a condenser opens up the low wavelength end of the scale at the expense of the upper end. In order that the scale may be as uniform as possible, the straight line frequency curve has been somewhat modified in the Type 374 Condensers so that the scale is better adapted to actual working conditions.

The general design of these condensers is the same as the Type 334 illustrated and described on the following page. The smaller area of the rotor plates makes it necessary to use double the number of plates that are used in the straight line wavelength type to obtain the same capacity. In order to get the proper support, the 500 M M F. size is made as a tandem balanced rotor type. Particular attention is called to the fact that the panel space required is identical with that of the Type 334 Condensers. This economy of panel space is a very advantageous feature.

- | | |
|---|--------|
| Type 374-B, 125 M M F. capacity..... | \$3.75 |
| Dimensions $3\frac{3}{4}$ " x $3\frac{3}{4}$ " x $3\frac{1}{4}$ ". Weight 1 lb. | |
| Code Word: "BONUS." | |
| Type 374-K, 250 M M F. capacity..... | \$4.25 |
| Dimensions $3\frac{3}{4}$ " x $3\frac{3}{4}$ " x $4\frac{1}{4}$ ". Weight 1 lb. 2 oz. | |
| Code Word: "BOSOM." | |
| Type 374-N, 350 M M F. capacity..... | \$6.50 |
| Dimensions $3\frac{3}{4}$ " x $3\frac{3}{4}$ " x 5". Weight 2 lbs. | |
| Code Word: "BOXER." | |
| Type 374-F, 500 M M F. capacity..... | \$7.00 |
| Dimensions $3\frac{3}{4}$ " x $3\frac{3}{4}$ " x 6". Weight 2 lbs. 2 oz. | |
| Code Word: "BRAVO." | |



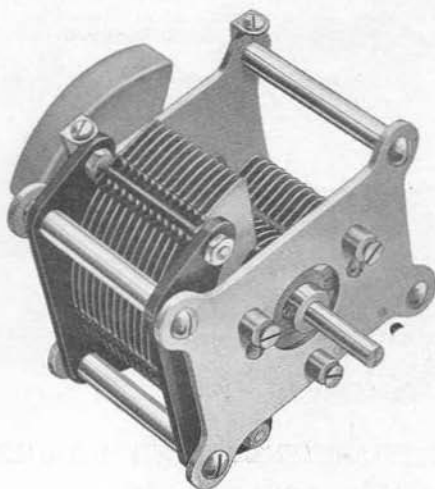

Type 334-F

VARIABLE CONDENSER

Grounded Rotor Type

In many popular receiving circuits the shielding of a condenser is important. To meet this specific need the Type 334 Condensers have been designed which have metal end plates and grounded rotor.

The rotor and stator units are the same as used in the Type 247 Condensers, and good conductivity is assured through solder-sealed contacts. The advantages of the soldered plate condenser are now well established in the minds of radio engineers.

End plates are of aluminum and condenser plates are of brass.

The Type 334 Condensers are made in panel mounting models only, with and without geared vernier.

For manufacturing uses we are prepared to supply this condenser in multiple sections under Hogan patent No. 1,014,002.

The construction of the Type 247 and 334 Condensers is also protected under General Radio patent No. 1,542,995.

Type 334-F, 500 M M F. Panel mounting, without gear.....\$4.25

Code Word: "BEGIN."

Type 334-H, 500 M M F. Panel mounting, with gear.....\$5.25

Code Word: "BELAY."

Type 334-N, 350 M M F. Panel mounting, without gear.....\$4.00

Code Word: "BESET."

Type 334-P, 350 M M F. Panel mounting, with gear.....\$5.00

Code Word: "BEVEL."

Type 334-K, 250 M M F. Panel mounting, without gear.....\$3.75

Code Word: "BELOW."

Type 334-M, 250 M M F. Panel mounting, with gear.....\$4.75

Code Word: "BERYL."

Dimensions 3¾" x 3¾" x 4½". Weight 1½ lbs.



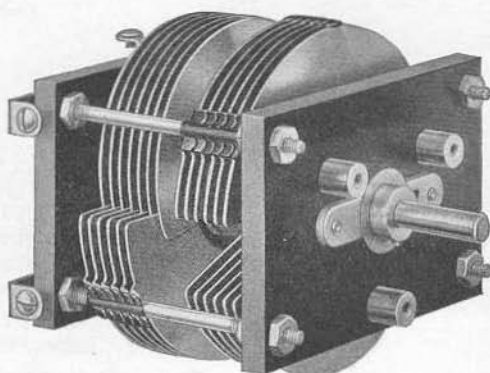

Type 248-K
TANDEM CONDENSER

The tendency in radio today is to simplify the operation of a receiving set by reducing its number of controls. The most popular method of accomplishing this is by the use of tandem condensers for the simultaneous tuning of two circuits, particularly in tuned radio frequency sets.

The Type 248 Tandem Condensers are assembled of rotor and stator units identical to those used in the Type 247 Condensers. This soldered type of construction insures that the capacities of both sections of the condensers will be very nearly identical—a most important point in multiple tuning.

The end plates are of hard rubber, rectangular in shape, and with the dielectric in a weak electrostatic field.

The rotor units are on opposite sides of the shaft and perfectly balanced.

Bearings are standard General Radio spring bearings, tight, yet smooth in operation, and designed to compensate for wear.

These condensers are particularly compact and rugged. Terminals are so arranged that the capacities of the individual units may be connected to different circuits or the total capacity of both sections may be connected in one circuit.

Type 248-F, 2 units each of 500 M M F. capacity.....\$6.50
Dimensions 3½" x 3¼" x 5¼". Weight 1 lb. 4 oz.
Code Word: "ABODE."

Type 248-N, 2 units each of 350 M M F. capacity.....\$6.15
Dimensions 3½" x 3¼" x 5½". Weight 1½ lbs.
Code Word: "ACORN."

Type 248-K, 2 units each of 250 M M F. capacity.....\$5.75
Dimensions 3½" x 3¼" x 5½". Weight 1 lb. 10 oz.
Code Word: "ABUSE."





**TYPE 334
TRANSMITTING CONDENSER**

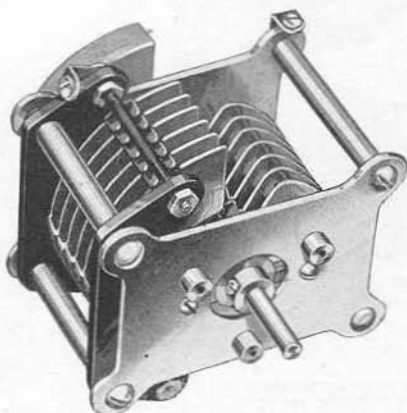

The Type 334-T and V condensers are similar in appearance and assembly to all other Type 334 condensers except that they have double spacing for use in short wave transmitting on voltages up to 2000. They have metal end plates. Plates of the rotor and stator groups are soldered to insure perfect electrical contact. The Type 334 transmitting condensers are supplied with counter weights only.

Type 334-T Transmitting Condenser, Capacity 100 M M F., Price.....\$4.25
Code Word: "BILLY."

Type 334-V Transmitting Condenser, Capacity 50 M M F., Price.....\$3.75
Code Word: "BIPEd."
Dimensions 3 3/4" x 3 3/4" x 4". Weight 1 lb. 4 oz.

TYPE 368 MICRO-CONDENSER

A small balancing condenser is often required in sets employing the recently developed circuits. Such a condenser should be as small as practical, and the mounting should be simple, preferably of the one-hole type. Such a condenser is available in the Type 368. This condenser has a maximum capacity of 15 M M F. It is of our standard low-loss soldered-plate type.

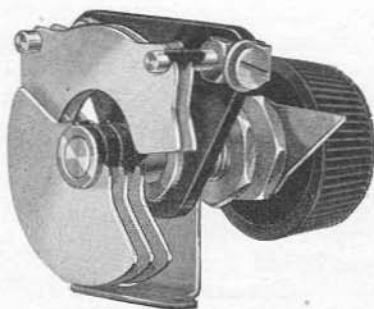

Type 368 Micro-Condenser, 15 M M F\$1.25
Dimensions 2" x 2" x 1 7/8". Weight 2 oz.
Code Word: "BULLY."

Type 368-B Micro-Condenser 50 M M F.....\$1.50
Dimensions 2" x 2" x 2". Weight 2 1/2 oz.
Code Word: "BURIN."



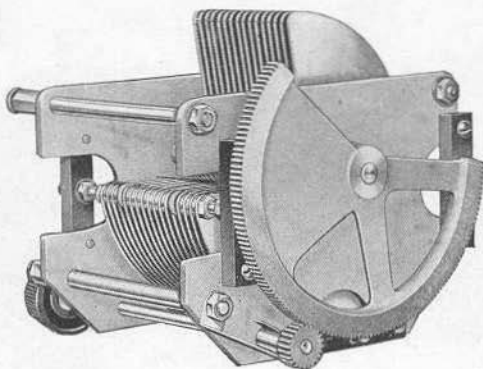

Type 239

LABORATORY CONDENSER

To meet the most exacting requirements of carefully designed radio sets, and for general laboratory use, the above illustrated Type 239 Condenser is particularly recommended. It is somewhat similar in design to the General Radio precision condenser. It has metal end plates, locked cone bearings, and is rigidly supported. The only solid dielectric material used is in the form of supporting strips for the fixed plates. These strips are of selected hard rubber, and are placed in a weak and non-varying electrostatic field. This reduces the dielectric loss to a minimum.

The rotor plates are grounded to reduce body capacity. The plates are of aluminum and are so shaped as to give a nearly uniform wavelength variation.

The Type 239 Condensers are supplied either with slow motion gear or counterweight.

A precise vernier adjustment is made possible on the models with counterweights by use of vernier dials shown on page 9261.

Type 239-H, 1000 M M F, unmounted, without gear.....	\$10.00
Dimensions $4\frac{1}{2}$ " x $4\frac{3}{4}$ " x 6".	Weight 2 lbs.
Code Word: "BARON."	
Type 239-G, 1000 M M F. unmounted, with gear.....	\$13.50
Dimensions $4\frac{1}{2}$ " x $4\frac{3}{4}$ " x 6".	Weight 2 lbs.
Code Word: "BASAL."	
Type 239-M, 2000 M M F. unmounted, without gear.....	\$13.00
Dimensions $4\frac{1}{2}$ " x $4\frac{3}{4}$ " x 6".	Weight 3 lbs.
Code Word: "BAYAN."	
Type 239-L, 2000 M M F, unmounted, with gear.....	\$16.50
Dimensions $4\frac{1}{2}$ " x $4\frac{3}{4}$ " x 6".	Weight 3 lbs.
Code Word: "BEFIT."	



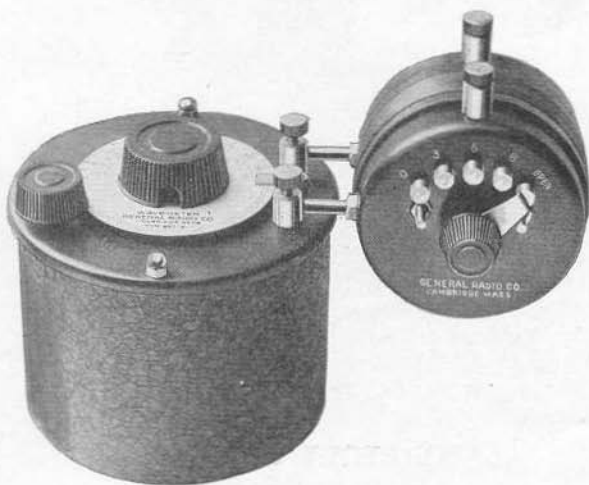

**Type 247-W
WAVEMETER AND FILTER**

The selectivity of a receiving set is greatly improved by a radio filter. Interference from various sources may also be reduced to a minimum by use of a reliable filter.

The Type 247-W Wavemeter is ideally adapted to this purpose. The filter coil may be connected either in series or parallel with the receiving set. When used in series connection a single interfering broadcasting station may be eliminated. The parallel filter is used to eliminate several interfering stations simultaneously and accept only one station within the filter range.

The range of the 247-W Wavemeter is 200 to 600 meters. Wavelengths may be determined by direct readings from the condenser dial which is calibrated with an accuracy of 2%.

A full set of instructions accompanies each instrument.

Type 247-W Wavemeter and Filter.....\$10.00

Dimensions 5" x 4½" x 8". Weight 2½ lbs.

Code Word: "WAGON."

When longer or shorter wavelengths are desired Types 247-W2, 247-W½, and 247-W¼ Extension Coils may be used interchangeably.

Type 247-W2 Extension Coil (400-1200 meters).....\$3.00

Dimensions 4" x 4" x 3". Weight 6 oz.

Code Word: "VOCAL."

Type 247-W½ Extension Coil (100-300 meters).....\$3.00

Dimensions 4" x 4" x 3". Weight 6 oz.

Code Word: "VIZOR."

Type 247-W¼ Extension Coil (50-150 meters).....\$3.00

Dimensions 4" x 4" x 3". Weight 6 oz.

Code Word: "VIVID."



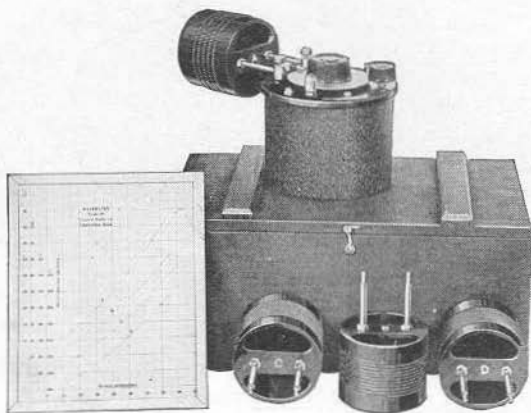

Type 358
AMATEUR WAVEMETER

The General Radio Type 358 Wavemeter is designed particularly for amateur use. It covers a wavelength range of approximately 14 to 220 meters, covering all the amateur bands in common use. The wavemeter consists of a mechanically rugged coil of low loss construction, mounting directly on the binding posts of a shielded condenser. The condenser capacity is 125 M M F. Mounted on the condenser panel and connected in series between the condenser and coil is a resonance indicator in the form of a small lamp. The lamp socket is so arranged that it is short circuited when the lamp is removed.

The wavelength range is covered by means of four coils. Each wavemeter is individually calibrated with an accuracy of 1%. A calibration curve is plotted for each coil and the curve sheet mounted on a substantial metal backing. The coil ranges, providing adequate overlaps, are as follows:

Coil A	14 to 28
Coil B	26 to 56
Coil C	54 to 114
Coil D	105 to 220

The condenser, coils and chart are contained in a wooden box which provides proper protection for the instrument when not in use.

Type 358 Wavemeter complete.....\$22.00

Dimensions 11 $\frac{3}{4}$ " x 7 $\frac{1}{4}$ " x 5 $\frac{1}{2}$ ". Weight 4 $\frac{1}{2}$ lbs.
Code Word: "UPPER."



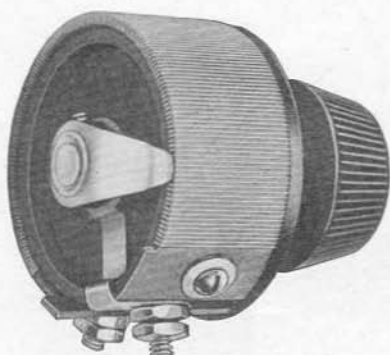

Type 301

RHEOSTATS

Rheostats used in vacuum tube circuits must be so constructed and the contact so arranged that there is no possibility of a momentary opening of the circuit, or a sudden change of resistance in the circuit. Either of these would result in an objectionable click in the ear phones or loud speaker.

The resistance of the Type 301 Rheostat changes gradually and uniformly throughout its entire range, and thereby secures the same degree of control for all working conditions of the battery. With the tubes now available and with the gradual change of resistance provided by the Type 301 Rheostat no vernier attachment is necessary.

The resistance unit is tightly wound on a specially treated fiber strip. Genuine moulded bakelite is used for the base. A tapered knob with pointer indicates position of the contact arm. The shaft is $\frac{1}{4}$ " in diameter and is arranged to fit panels up to $\frac{3}{8}$ " thick.

Type 301 Rheostat.....\$1.25

Dimensions 2" x 1 $\frac{3}{4}$ " x 2 $\frac{1}{8}$ ". Weight 4 oz.

Resistance	Current	Code Word
6 ohms	1.00 amp.	PALSY
12 "	0.75 "	REMIT
25 "	0.5 "	RENEW

In ordering be sure to specify resistance desired.

POTENTIOMETERS

The potentiometer is similar in general construction to the rheostat except that a third connection is provided and it has a greater resistance.

Type 301—200 ohm Potentiometer.....\$1.25

Dimensions 2" x 1 $\frac{3}{4}$ " x 2 $\frac{1}{8}$ ". Weight 4 oz.

Code Word: "REBUS."



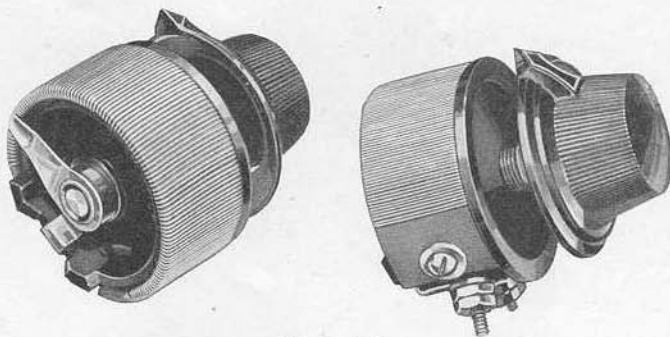

Type 410

RHEOSTATS

The Type 410 rheostats are similar in general appearance and construction to the Type 301 rheostat described on the opposite page, except that they have the single hole mounting feature.

This method of mounting to the panel is preferred by many experimenters because it eliminates the bother of locating and drilling two mounting screw holes. In the case of the Type 410, the bushing for the shaft serves to mount the rheostat to the panel.

In electrical characteristics, the Types 301 and 410 are identically the same.

The resistance wire is tightly wound on a specially treated fibre strip. The base is of genuine moulded Bakelite. The tapered knob which is also of moulded Bakelite, has an engraved pointer which indicates the position of the switch arm along the arc of the resistance unit.

The shaft is $\frac{1}{4}$ " in diameter and the outside diameter of the bushing is $\frac{3}{8}$ ". The length of the bushing is such that the rheostat may be easily mounted on panels up to $\frac{3}{8}$ " in thickness.

Type 410 Rheostat\$1.25

Dimensions 2" x $1\frac{3}{4}$ " x $2\frac{1}{4}$ ". Weight 4 oz.

Resistance	Current	Code Word
6 ohms	1.00 amp.	SABOT
12 "	0.75 "	SALON
25 "	0.5 "	SALTY

In ordering, be sure to specify resistance desired.

POTENTIOMETERS

In general construction the potentiometer is similar to the rheostat except that a third connection is provided and it has a greater resistance.

Type 410—200 ohm Potentiometer.....\$1.25

Dimensions 2" x $1\frac{3}{4}$ " x $2\frac{1}{8}$ ". Weight 4 oz.

Code Word: "SATIN."



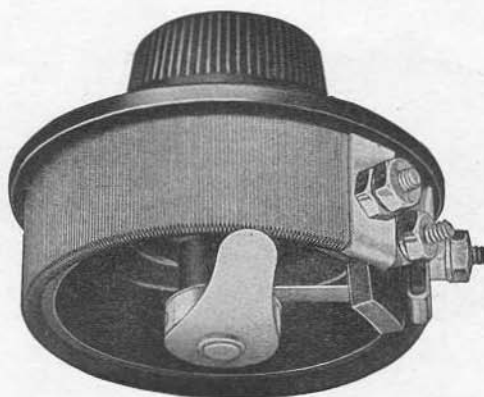

Type 214

RHEOSTATS

Where the best in rheostat construction is desired, and for laboratory use, the Type 214 is particularly recommended. This rheostat is made in two types, 214-A for back of panel mounting and 214-B for front of panel or table mounting. The Type 214 Rheostats are larger than the Type 301 Rheostats, and are therefore capable of a more gradual and accurate resistance control. It is similar in general construction to the Type 301, and embodies the best of materials and workmanship.

Type 214 Rheostat.....\$2.25
Dimensions 3" dia. x 2¼". Weight 7 oz.

CODE WORD

Resistance	Current	Type 214-A	Type 214-B
		Panel Mounting	Table Mounting
2 ohms	2.5 amp.	RUDDY	RUMOR
7 ohms	1.5 amp.	RURAL	RUSTY
20 ohms	0.75 amp.	RAZOR	READY
50 ohms	0.5 amp.	RAPID	RAVEL

POTENTIOMETERS

Many of the most efficient circuits now in common use require a potentiometer to control the grid potential. The Type 214 is supplied with a high resistance winding and a third connection which enables it to be used as a potentiometer capable of extremely fine voltage control.

Type 214—400 ohm Potentiometer.....\$3.00
Dimensions 3" dia. x 2¼". Weight 7 oz.
Code Word, Type 214-A, panel mounting: "ROSIN."
Code Word, Type 214-B, table mounting: "ROWEL."



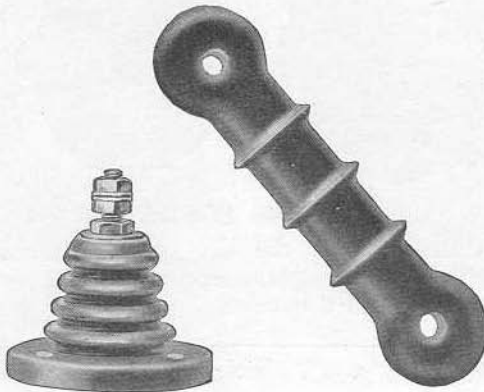

Type 260

Type 280

PORCELAIN INSULATORS
ANTENNA INSULATOR

For antenna insulation, correctly designed porcelain strain insulators are to be preferred to other commercial types. The Type 280 Strain Insulator, illustrated above, will be found particularly satisfactory. It is made of carefully glazed brown porcelain and will withstand severe weather conditions.

Type 280—Strain Insulator\$0.15
Dimensions $4\frac{1}{2}'' \times 1\frac{1}{8}'' \times 1''$. Weight 4 oz.
Code Word: "CRULLER."

WALL INSULATOR

Another convenient insulator is the Type 260, illustrated above. It may be used inside to support wiring or instruments, or may be used outside for supporting lead-ins or ground wires. Two of these insulators with a threaded rod connecting them make an excellent lead-in combination. As they are also constructed of glazed brown porcelain they may be used either indoors or out.

Each insulator is equipped with nuts and washers assembled, as shown above.

Three polished nickel mounting screws are also provided.

Type 260—Insulator\$0.25
Dimensions $2\frac{1}{8}'' \times 2\frac{1}{8}'' \times 2''$. Weight 4 oz.
Code Word: "CONIC."



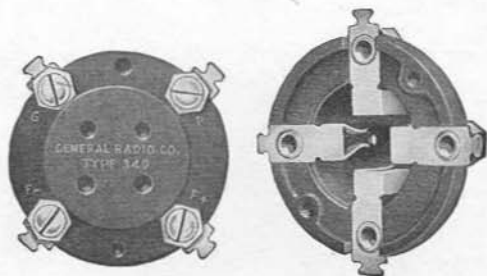

TYPE 349 SOCKET

This socket is designed for the UX types of tubes. Positive contacts are made with double gripping springs to the sides of the tube prongs. The base is of moulded bakelite.

Type 349 Socket.....\$0.50

Dimensions $2\frac{1}{4}'' \times 2\frac{1}{4}'' \times \frac{3}{4}''$. Weight 2 oz.

Code Word: "SEDAN."

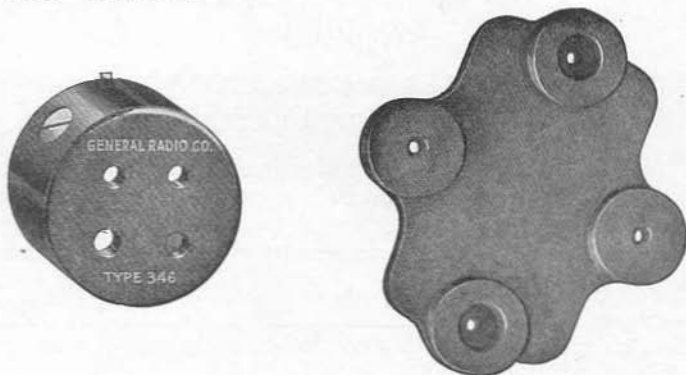

Type 346

Type 309

TYPE 346 ADAPTER

The Type 346 Adapter enables the UX-199 and UX-120 tubes to be used in standard tube sockets. The adapter is of moulded bakelite. A set-screw is provided for securing the tube base firmly in the adapter.

Type 346 Adapter.....\$0.30

Dimensions $1\frac{1}{2}'' \times 1\frac{1}{2}'' \times \frac{7}{8}''$. Weight 1 oz.

Code Word: "AMASS."

TYPE 309 SOCKET CUSHION

Many of the undesirable noises heard in a radio set are due to the microphonic action of the tubes. This condition can be eliminated by the use of the Type 309 Socket Cushion under the Types 156, 299, and 346 Sockets. This cushion is of sponge rubber and gives complete protection. Mounting is from the tube socket to the cushion, then from the cushion to the sub-panel.

Type 309 Socket Cushion.....\$0.35

Dimensions $2\frac{1}{4}'' \times 2\frac{1}{2}'' \times \frac{3}{8}''$. Weight 1 oz.

Code Word: "SABER."



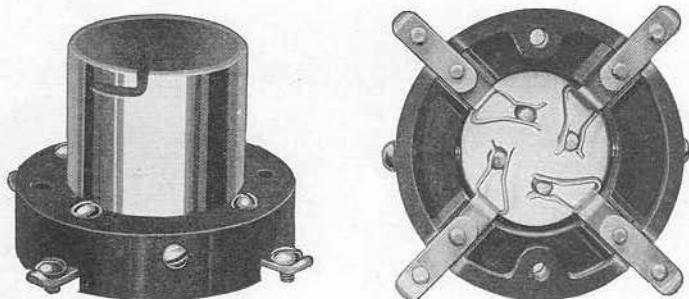

Type 156

A vacuum tube socket must be more than a tube mounting device. It must not only hold the tube securely to prevent vibration, but also must make firm electrical contact with the four tube prongs. In the design of all General Radio sockets care has been given in each case to make the socket meet specifically the requirements of the tube it is to be used with. This is the reason that the three types are distinctly different in their design.

TYPE 156 SOCKET

This socket is designed for tubes using what was formerly known as the standard base. These tubes include the UV-200, UV-201-A, UV-202, and WD-12. The phosphor bronze contact springs are so arranged as to make positive contact on the sides of the tube prongs. The wiping action of these double contact springs assures a clean positive connection. The tube is of heavy brass with highly polished nickel finish and carefully grooved bayonet slot to take the tube base locking pin.

Type 156 Socket.....\$1.00

Dimensions $3\frac{1}{2}'' \times 2\frac{1}{2}'' \times 1\frac{3}{4}''$. Weight 4 oz.

Code Word: "SOBER."

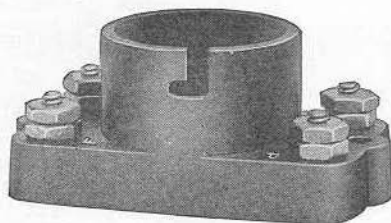

TYPE 299 SOCKET

The springs of this socket, which is designed for the UV-199 tubes, are multiple, and make a spring contact to the bottom of the tube prongs. Special attention has been given to provide for a low resistance contact.

Type 299 Socket.....\$0.50

Dimensions $2\frac{3}{8}'' \times 1\frac{3}{8}'' \times 1''$. Weight 2 oz.

Code Word: "STORY."

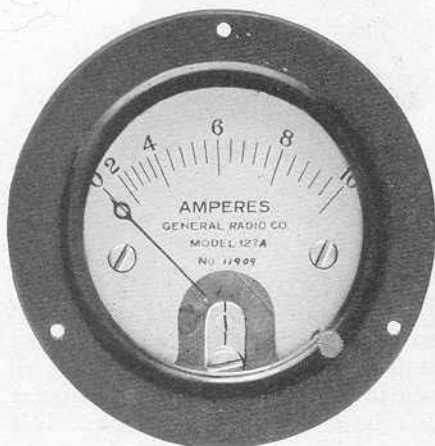

Type 127-A

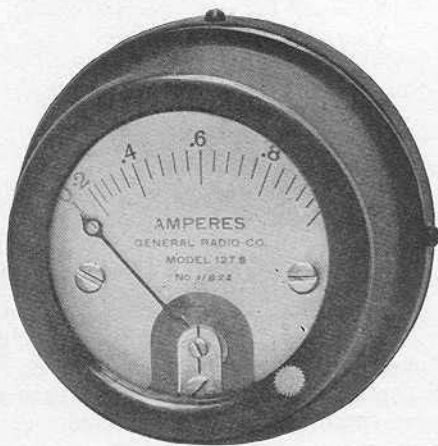

Type 127-B

HOT WIRE AMMETERS

The Type 127 Hot Wire Ammeters are equally accurate on direct or alternating currents of any frequency. They may be used for measuring filament currents, storage battery charging rates, antenna radiation, and many other purposes.

The expanding strip of these meters is of thin platinum, so as to prevent oxidation. It is so proportioned that it works at a low temperature and is of low resistance. These are two highly desirable features, since the former permits reasonable overloading without burning out, and the latter minimizes the losses.

The type of multiplying action is such that a more uniform scale is obtained than with many hot wire meters. These meters have been corrected for temperature so that there is very little shift of zero, and this is easily taken care of by the knurled adjusting screw.

These instruments are made in three types, the flush mounting for use on panels, the front-of-board mounting for use on switch boards, and the portable type for general use. The flush type meters are mounted in metal cases finished in black japan, while the front-of-board and portable types have cases of moulded bakelite.





Type 127-C

CODE WORD

Range		TYPE 127-A Flush Mounting	TYPE 127-B Front-of-Board	Price
100	Milli-Amperes.	MEDAL	MAYOR	\$9.00
250	Milli-Amperes.	MERCY	MADAM	7.75
500	Milli-Amperes.	MERIT	MAJOR	7.75
1	Ampere	MERRY	MANOR	7.75
1.5	Amperes	MINUS	MISTY	7.75
2.5	Amperes	MINOR	MAPLE	7.75
5	Amperes	MINIM	MATIN	7.75
10	Amperes	MINNY	MAXIM	7.75
	Galvanometer	MITER	MAGIC	7.25

Dimensions 3" x 1½". Weight 9½ oz.

Range		Type 127-C Code Word	Case	Price
100	Milli-Amperes.	MUGGY	Portable	\$10.00
250	Milli-Amperes.	MOCHA	Portable	9.00
500	Milli-Amperes.	MOGUL	Portable	9.00
1	Ampere	MOLAR	Portable	9.00
2.5	Amperes	MOTOR	Portable	9.00
5	Amperes	MUMMY	Portable	9.00
10	Amperes	MUSTY	Portable	9.00
	Galvanometer	MOTTO	Portable	8.50



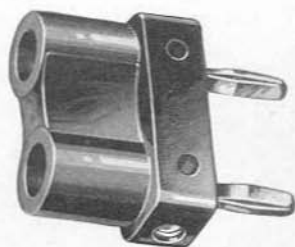

Type 274-M

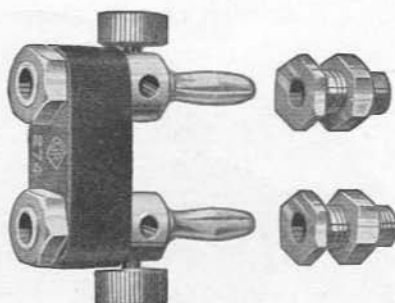

Type 274

MULTI-CONNECTOR PLUGS

For many experimental uses on radio work a plug and jack combination is far handier than binding posts. Particularly at high voltages, the conventional telephone type of plug is not practical. To meet this general need the Type 274-M Insulated Plug was developed.

By using these plugs any number of series or parallel combinations may be provided.

Type 274-M—Multi-Connector Plug.....\$0.50

Dimensions $1\frac{3}{4}'' \times 1\frac{1}{2}'' \times \frac{5}{8}''$. Weight 2 oz.

Code Word: "PATTY."

Similar to the Type 274-M Insulated Plug is the Type 274 Plug. Thumb screws are used in place of set screws to secure the contact wires. This plug, while somewhat more adaptable than the Type 274-M Insulated Plug should be used only with low voltages.

Type 274—Multi-Connector Plug, complete with jacks.....\$1.00

Dimensions $1\frac{1}{2}'' \times 1\frac{5}{8}'' \times \frac{1}{2}''$. Weight 2 oz.

Code Word: "PAPER."

TYPE 236 BY-PASS CONDENSER

It is often advisable to by-pass portions of a radio circuit with a condenser of fairly large capacity in order to reduce the audio frequency impedance of that portion of the circuit.

A by-pass condenser across the "B" battery is particularly helpful in eliminating oscillations in the audio amplifier, due to long leads, or a high resistance in the common "B" battery.

The Type 236 Condenser is impregnated with paraffin as wound, and mounted in a substantial metal container.

Type 236—.5 M F. By-Pass Condenser.....\$1.00

Dimensions $4'' \times 1\frac{1}{8}'' \times 1\frac{1}{8}''$. Weight 5 oz.

These condensers may also be supplied with capacities of .1, .2, .3 and .4 M.F. without change in price.

Code Word: "PECAN."



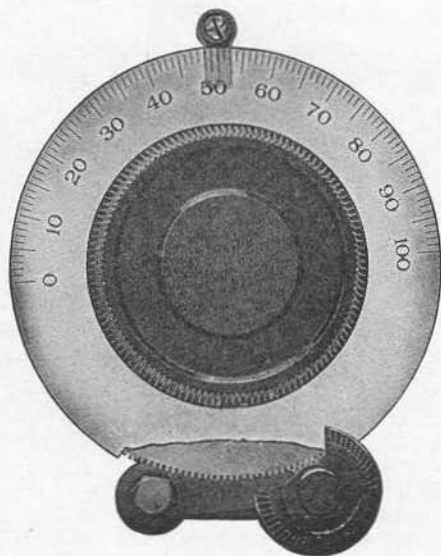

Type 303

VERNIER DIALS
Frosted Silver Finish

The Types 302 and 303 Dials are provided with a specially designed vernier attachment. A brass gear with accurately machined teeth is swaged firmly to the back of the dial. A small fibroil pinion under the vernier knob is kept in tight contact with this gear by a spring arm. The finish of the dial is frosted silver with graduated scale in black. Extremely accurate adjustments are made possible by the use of this vernier dial, inasmuch as there is absolutely no backlash. Each dial is packed with a celluloid hair line indicator and template for drilling panel for mounting the spring arm.

- Type 302—2¾ in. Vernier Dial, for ¼ in. Shaft.....\$1.75
Dimensions 3½" x ¾". Weight 6 oz. Code Word: "DAISY."
- Type 303—4 in. Vernier Dial, furnished for ¼ in. or ⅜ in. Shaft.....\$2.50
Dimensions 4⅝" x ¾". Weight 10 oz. Code Word: "DALLY."

DIAL AND INDICATOR
Without Vernier

The Type 310 Dial and Indicator combination permits precise dial setting and is a great help in logging stations. The dial is of brass with a frosted silver finish and graduated scale in black. The knob is of bakelite. The indicator of transparent celluloid with fine line is mounted by a nickel finished screw and nut.

The construction features of the Type 317 Dial are similar to those of the Type 303 Dial, except that it is without vernier gear.

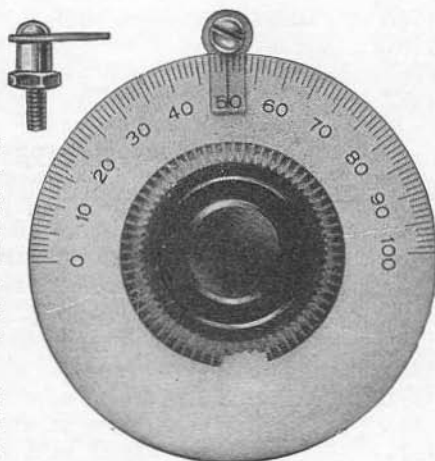

Type 310

- Type 310—2¾ in. Dial and Indicator.....\$0.60
Dimensions 2¾" x ⅝". Weight 3½ oz. Code Word: "DANDY."
- Type 317—4 in. Dial and Indicator.....\$1.50
Dimensions 4" x ¾". Weight 6½ oz. Code Word: "DEBUT."





GENERAL RADIO

PARTS AND ACCESSORIES

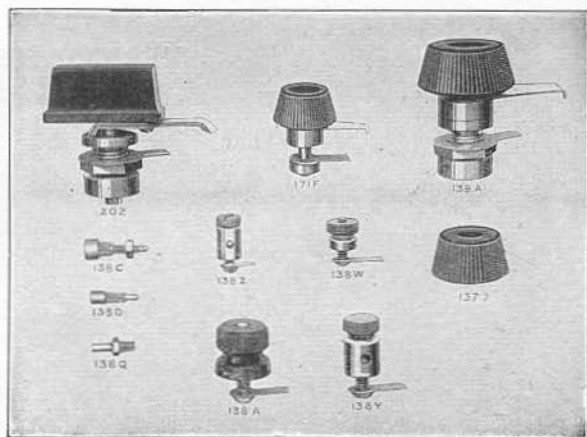

STANDARD PARTS

Experimental work frequently requires certain standard parts. Consequently we are listing for the convenience of experimenters many of the parts used in the assembly of General Radio instruments. These parts have the advantage of matching those used on instruments already installed.

BINDING POSTS

Type	Description	Diameter	Height	Screw Sizes	Price
138A	Bakelite	$\frac{3}{4}$ "	$\frac{5}{8}$ "	10-32	\$0.25
138W	N. P. Brass	$\frac{7}{16}$ "	$\frac{1}{2}$ "	6-32	.12
138Y	" "	$\frac{1}{2}$ "	$\frac{3}{4}$ "	10-32	.15
138Z	" "	$\frac{3}{8}$ "	$\frac{5}{8}$ "	6-32	.10

SWITCHES AND PARTS

Type	Description	Price
139A	Multiple Leaf Switch $1\frac{3}{8}$ " Radius	\$0.95
171F	Single Leaf Switch $\frac{7}{8}$ " Radius	.40
202	Low Contact Resistance Switch $\frac{3}{8}$ " Radius	1.25
138C	$\frac{5}{16}$ " Contact for 139A or 202 Switches	.05
138D	$\frac{3}{16}$ " Contact for 171F Switch	.04
138Q	Switch Stop with Nut	.05
137D	Moulded Knob (same as used on 139A Switch)	.35
137H	Moulded Knob (same as used on 317 Dial)	.75
137J	Moulded Knob (same as used on 301 Rheostat)	.25
137K	Moulded Knob (same as used on 247 Vernier)	.25

The Types 137D and J Knobs are for $\frac{1}{4}$ " shaft, while the 137H may be supplied for either $\frac{1}{4}$ " or $\frac{3}{8}$ " shafts. The 137K Knob is tapped for a 10-32 thread. The Types 137D and 137J Knobs may be supplied with polished nickel pointers for five cents additional.



The **UNIVERSAL STANDARDS** of RADIO





Quality Easily Recognized

