



INSTRUCTION MANUAL

Type 1807
**Dc Microvoltmeter/
Nanoammeter**

A

GENERAL RADIO



Contents

SPECIFICATIONS
CONDENSED OPERATING INSTRUCTIONS
INTRODUCTION – SECTION 1
INSTALLATION – SECTION 2
OPERATION – SECTION 3
THEORY – SECTION 4
SERVICE AND MAINTENANCE – SECTION 5
PARTS LISTS AND DIAGRAMS – SECTION 6

WARRANTY

We warrant that each new instrument manufactured and sold by us is free from defects in material and workmanship and that, properly used, it will perform in full accordance with applicable specifications for a period of two years after original shipment. Any instrument or component that is found within the two-year period not to meet these standards after examination by our factory, District Office, or authorized repair agency personnel will be repaired or, at our option, replaced without charge, except for tubes or batteries that have given normal service.

Type 1807
**Dc Microvoltmeter/
Nanoammeter**

A

©GENERAL RADIO COMPANY 1969

West Concord, Massachusetts, U.S.A. 01781

Form 1807-0100-A

March, 1969

ID-0100



Condensed Operating Instructions

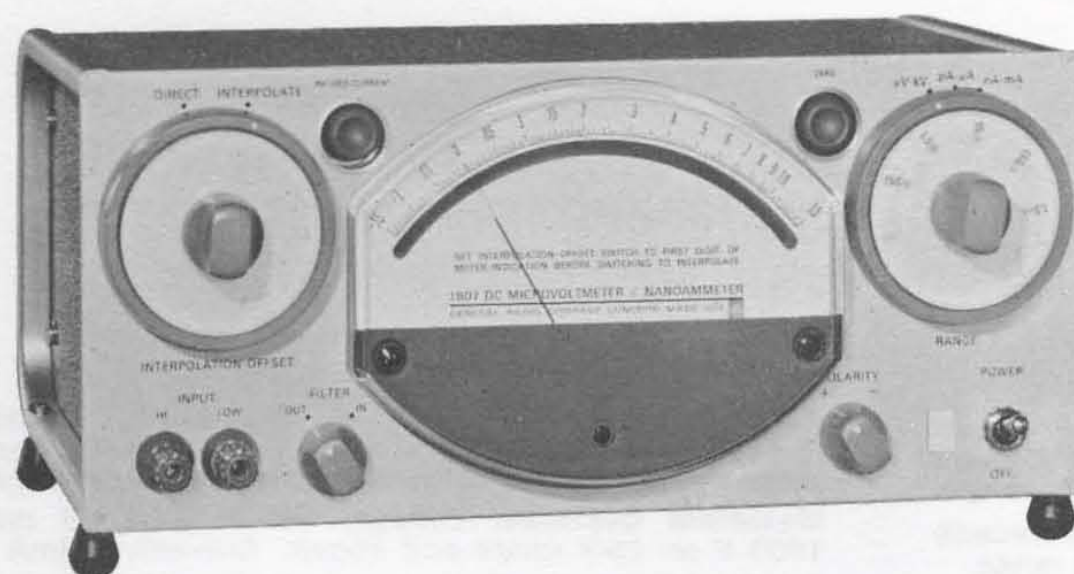

DC Microvoltmeter/Nanoammeter

CAUTION

Do not apply more than 150 V on the 1.5-V range or below. Make sure that the RANGE switch is set to μV - kV before a voltage to be measured is applied to the instrument. Do not apply more than 10 V to the instrument when the RANGE switch is set to any nA or mA range; use external shunts when current greater than 10 mA is applied to the instrument.

GENERAL.

Use all-copper wires (including any connectors) if interconnecting μV or pA sources and set the FILTER switch to IN when measuring voltage or current in this range. For maximum accuracy when using the interpolation-offset feature on the 150- μV and 1.5-mV ranges, check the meter-zero in the manner described in Section 3. Adjust the meter-zero occasionally, to calibrate the sensitive ranges.

TURN ON.

- Set the RANGE controls to the desired range and position corresponding to the type of signal being measured, observing the cautions described above.
- Set the INTERPOLATION OFFSET switch to DIRECT and the POLARITY switch to the appropriate position.
- Connect the unknown signal to the INPUT terminals.
- If "floating" or bridge measurements are being made, disconnect the shorting bar between the LO terminals on the rear panel, even when using the front-panel INPUT terminals.
- Set the POWER switch to ON.

VOLTAGE MEASUREMENTS.

- Set the RANGE switch to approximately the range of the measured voltage, observing the cautions described above; set the INTERPOLATION switch to DIRECT, and set the POLARITY switch to the appropriate position.
- Read the voltage on the meter scale, taking into account the position of the RANGE switch. If greater accuracy is required, refer to "INTERPOLATION," below.

CURRENT MEASUREMENTS.

Perform steps a and b, above, except use the current range of the RANGE control and set the FILTER switch to IN if the current is in the pA to μA range.

INTERPOLATION.

- Set the INTERPOLATION OFFSET knob control to the first digit of the meter reading if the reading is below 1.0, or to the first two digits if the reading is between 1.0 and 1.5.
- Set the INTERPOLATION ring dial to INTERPOLATE; the position of the inner dial indicates the first digit, or digits, of the reading and the meter indicates the following digits.

USE WITH A RECORDER.

Connect the recorder or other monitoring device to the rear-panel RECORDER jack and adjust the RECORD CURRENT adjustment for the desired recorder response; if the INPUT LO terminal on the rear panel is grounded, do not ground the recorder.

Specifications

RANGE

Voltage (either polarity): 15 μV to 1500 V full scale in 9 decade ranges; 0.05- $\mu\text{V}/\text{div}$ resolution near zero on most sensitive range.

Current (either polarity): 15 pA to 1.5 mA full scale in 9 decade ranges; 0.05-pA/div resolution near zero on most sensitive range.

ACCURACY

Record-Current Linearity: $\pm(0.1\%$ of reading + 0.5 μV).

Interpolate: $\pm[0.1\%$ of full scale (range) + 0.1% of reading + 0.5 μV].

Direct: $\pm(1.5\%$ of reading + 0.5 μV) above 10% of full scale. $\pm(0.1\%$ of full scale + 0.1% of reading + 0.5 μV) below 10% of full scale.

Temperature Coefficients (typical)

Record-Current Zero Drift: $\pm(0.001\%$ of full scale + 0.15 μV) per degree C.

Interpolate: $\pm(0.001\%$ of reading + 0.001% of full scale + 0.15 μV) per degree C.

Direct: $\pm(0.02\%$ of reading + 0.001% of full scale + 0.15 μV) per degree C.

INPUT IMPEDANCE

Voltage: 150- μV to 1.5-V ranges, $> 500 \text{ M}\Omega$ on direct and typically 5,000 $\text{M}\Omega$ on interpolate; 15- μV range, $> 50 \text{ M}\Omega$; 15-V to 1500-V ranges, 10.5 $\text{M}\Omega$.

Current: Internal Shunts, 1 $\text{M}\Omega$ in pA-uA ranges, 1 $\text{k}\Omega$ in nA-mA ranges.

Meter: Single scale from -1.5 to 15. Logarithmic (20 dB) above 10% of full scale.

Input Current: Less than 5 pA.

Noise: Typically 0.5 μV for 3σ with 1 $\text{k}\Omega$ across input.

Common-Mode Rejection: $>160 \text{ dB}$ for dc with up to 600 V dc max above ground; $>120 \text{ dB}$ for 60-Hz common-mode signal of $<8 \text{ V}$ pk with input filter.

Record-Current Response Time (typical): 0.1 s without input filter (1.5-Hz bandwidth, 0.3 s with filter (0.5-Hz bandwidth) on all ranges above 15 μV ; 10 times slower on 15- μV range.

Maximum Overload: Voltage: 150 V on 1.5-V range and below, 1500 V on 15-V range and above. Current: 10 mA max all ranges.

Overload Recovery Time: Approx 3 s for 10^6 overload.

Recorder Output: Adjustable up to $\pm 2.5 \text{ V}$ open circuit for full scale meter deflection; $\pm 1 \text{ mA}$ into 1.5 $\text{k}\Omega$ max load.

GENERAL

Terminals: Gold-plated copper binding posts on front and rear panels. Ground connection on rear panel only.

Power Required: 105 to 125, 205 to 250 V, 50 to 60 Hz, 5 W. Also operates from external 24-V dc supply; 1538-P3 Battery and Charger recommended.

Accessories Supplied: Power cord, spare fuse.

Accessories Available: Input probe, Tektronix type P6028, with type 274-QBJ (adapts binding posts to BNC); 1538-P3 Battery and Charger.

Mounting: Convertible-Bench Cabinet.

Dimensions (width x height x depth): Bench, 12 x 5 $\frac{7}{8}$ x 10 $\frac{1}{4}$ in. (305 x 150 x 260 mm); rack, 19 x 5 $\frac{1}{4}$ x 8 $\frac{1}{2}$ in. (485 x 135 x 220 mm).

Net Weight: Bench, 9 $\frac{1}{2}$ lb (4.4 kg); rack, 10 $\frac{3}{4}$ lb (4.9 kg).

Shipping Weight: Bench, 16 $\frac{1}{2}$ lb (7.5 kg); rack, 18 lb (8.5 kg).

Catalog Number	Description
1807-9700	1807 DC Microvoltmeter / Nanoammeter Bench Model Rack Model Input probe, Tektronix type P6028
1807-9701	
1807-9601	

See *General Radio Experimenter*, August-September 1968.

NOTE: This instrument is equipped with our new snap-on knob for added convenience and safety. Refer to the Service Section for details.



Introduction—Section 1

1.1 PURPOSE	1-1
1.2 DESCRIPTION	1-1
1.3 CONTROLS AND CONNECTORS	1-4
1.4 ACCESSORIES SUPPLIED	1-4
1.5 ACCESSORIES AVAILABLE	1-4
1.6 PATCH CORDS AND ADAPTORS	1-4

1.1 PURPOSE.

The 1807 Dc Microvolter/Nanoammeter is a sensitive, general-purpose dc voltmeter combining the features of microvoltmeter, nanoammeter, null detector, and differential voltmeter, all with 0.2% accuracy. As a microvoltmeter it provides nine decade measurement ranges, from 15 μV (with resolution of 0.05 μV) to 1500 V full-scale, with an input filter provided for noise suppression.

As a nanoammeter it also provides nine decade measurement ranges, from 15 pA (0.05-pA resolution) to 10 mA full-scale (or higher with external shunts).

As a null detector the 1807 has a common-mode rejection ratio of greater than 160 dB and a 3-s recovery time for a 10^6 overload, and as a differential voltmeter it offers accuracy 10 times better than that of conventional voltmeters.

The high accuracy is obtained by an accurately calibrated interpolation offset, or zero-suppression feature, which allows any segment of the meter scale to be expanded for 10 times better accuracy and resolution. High input impedance ensures full benefit from the instrument's precision without the need of loading-effect corrections. A single log/linear meter scale provides uniform accuracy over the entire range and high resolution near zero. The meter also allows unipolar readings; the polarity is selected at the front panel, allowing the measurement of dc voltages of the opposite polarity which do not exceed 10% of the full scale. Shunts, selectable at the front panel, provide the current-measurement capability.

The instrument can be operated from 115 or 230 V ac, 50 to 60 Hz, or from a 24-V battery source; both sources can be connected simultaneously, if desired. A GR 1538-P3 24-V Battery and Charger is available as an accessory, for supplying external power, if desired.

Minute voltages and currents (to as little as 0.5 pA), such as are encountered in biological, chemical, and medical research, can be readily measured with the 1807. The

instrument also serves well in the measurement of thermal voltages, ionization currents and similar phenomena of interest in the electronics and physics laboratory. An output is provided to drive dc recorders for plotting permanent records.

Several characteristics of the 1807 make it especially useful as a null indicator for use with dc bridges. An isolated input, excellent rejection of both dc and 60-Hz common-mode signals, the up-scale meter zero for unambiguous null definition, high input impedance, possible operation from a battery, and fine resolution near zero all contribute to this application.

The instrument's specifications are listed at the front of the manual.

1.2 DESCRIPTION.

The 1807 is assembled in a metal cabinet ready for bench use. A Rack Adaptor Set (P/N 0480-9832) is available for installation of the instrument in a EIA standard 19-in.-wide relay rack.

Front-panel binding posts are gold-plated copper to keep thermal electromotive forces (emf's) to a minimum, and alternate input connectors on the rear panel are convenient for permanent connection in rack-mounted assemblies. A GR 274-QBJ Adaptor is supplied as an accessory to provide a shielded connection from the standard 3/4-in. binding posts to a type-BNC plug.

Most of the instrument's circuit components, including calibration adjustments (see Figure 5-2), are on one etched-circuit board. Other circuit components are on the front and rear panels and transformer T501 terminal board. These components are easily accessible by loosing the captive screws on the rear of the instrument and removing the dust covers.

The front feet are adjustable to permit tilting for easy viewing of the front panel.



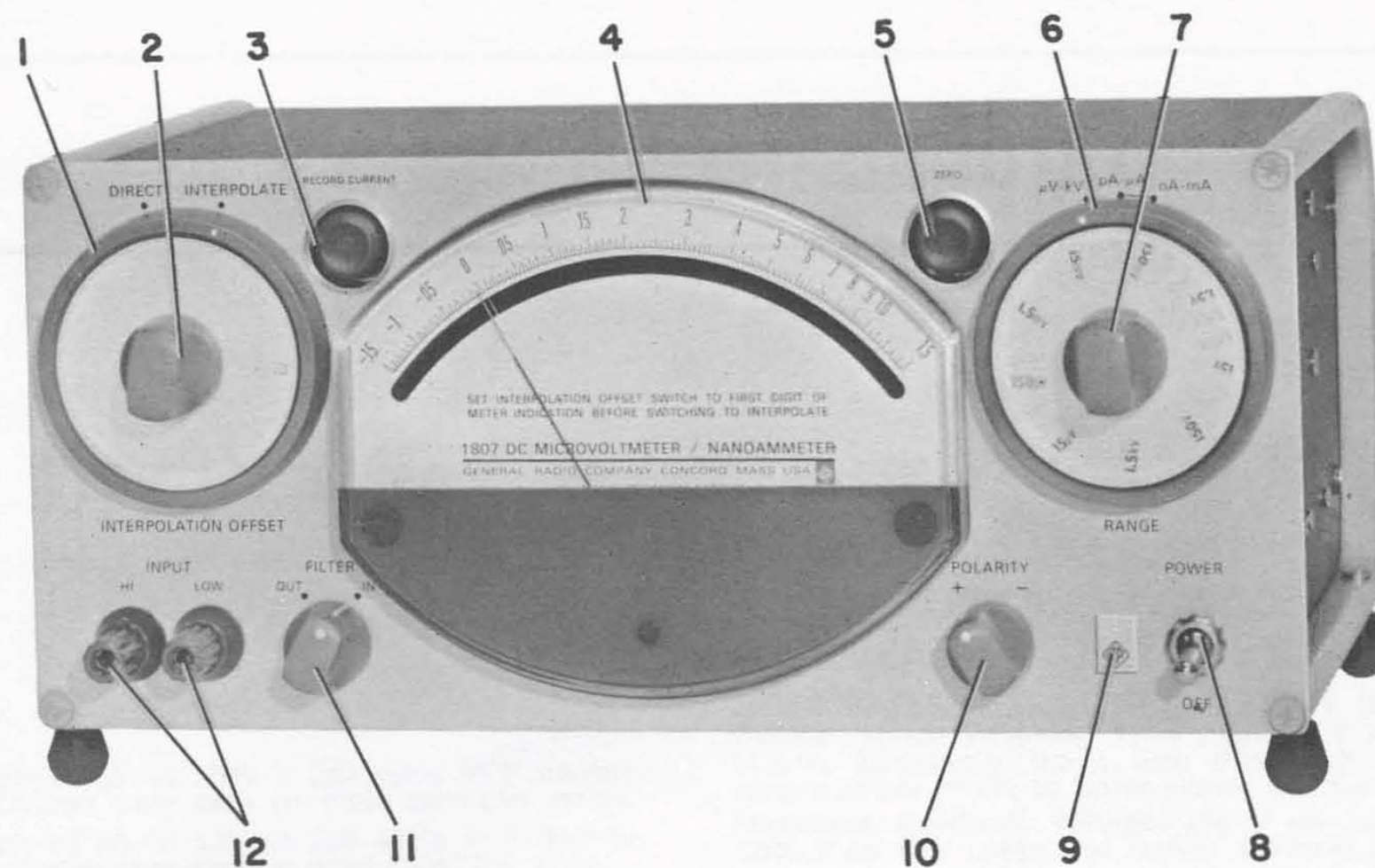

Figure 1-1. Front-panel view of the 1807.

Table 1-1
FRONT-PANEL CONTROLS, CONNECTORS, and INDICATORS

Fig. 1-1 Ref. No.	Name	Type	Function
1	INTERPOLATION OFFSET DIRECT- INTERPOLATE	Two-position rotary switch (outer dial)	When set to DIRECT, the meter reads directly the measured voltage or current in the range determined by the RANGE switch. When set to INTERPOLATE and the INTERPOLATE OFFSET 16-position rotary switch is set to the first digit (or first two digits of numbers between 1.0 and 1.5) of the direct meter reading, the meter scale is expanded ten times, indicating two or more of the following digits of the setting of the INTERPOLATION OFFSET 16-position rotary switch.
2	INTERPOLATION OFFSET	Sixteen-position rotary switch	Used in conjunction with the outer DIRECT-INTERPOLATE switch to interpolate a direct meter reading. The switch should be set to the first digit of a direct reading below 1.0 and to the first two digits of a direct reading between 1.0 and 1.5.
3	RECORD CURRENT	Thumbset adjust- ment	Adjusts the level of output at the rear-panel RECORDER jack ± 2.5 V open circuit for full scale reading; ± 1 mA into a 1.5 k Ω max. load.

Table 1-1 (cont)			
Fig. 1-1 Ref. No.	Name	Type	Function
4	Meter	Microvoltmeter/ nanoammeter	Indicates dc voltages from microvolts to kilovolts and dc currents from picoamps to milliamps (or higher, using external shunts) in ranges determined by the setting of the RANGE switch.
5	ZERO	Thumbset adjustment	Adjust the meter zero reading for the more sensitive measurement ranges (first three groupings on the RANGE switch). The effect of the adjustment is negligible on the higher ranges.
6	RANGE	Three-position rotary switch (outer dial)	Sets the meter measurement function for volts or current. The μV -kV position is for voltages within this range and the μA -mA and nA-mA positions are for current. The current ranges overlap.
7	RANGE	Nine-position rotary switch	Provides measurement ranges within each of the three limits established by the setting of the outer RANGE switch.
8	POWER	Toggle switch, DPST	When set to ON, energizes the instrument.
9	—	Pilot lamp	Lights when the instrument is energized.
10	POLARITY	Two-position switch	When set to +, the meter reads positive voltages. When set to -, the meter reads negative voltages on the above-zero part of the meter. However, voltages opposite the polarity setting can be read without changing the switch setting, provided the voltage does not exceed 10% of the full scale.
11	FILTER		When set to IN, connects a filter to the input for suppressing noise superimposed on dc voltages and currents. The switch can be set to ON whenever the signal source impedance is large compared to 10 k Ω or when measuring microvolts or picoamps.
12	INPUT	Jack-top binding-post pair	Connection for the signal to be measured. The binding posts are in parallel with the rear-panel INPUT terminals. The LOW binding post can be connected to the chassis via a shorting link between the rear-panel LO INPUT binding posts and, via the power cord, to ground.

1.3 CONTROLS AND CONNECTORS.

Figure 1-1 shows the front-panel controls and connectors, and Table 1-1 contains a description of the controls and indicators. Table 1-2 contains a description of the rear-panel connectors.

1.4 ACCESSORIES SUPPLIED.

The following accessories are supplied with the 1807:

1. Power Cord, 3-wire, 7-ft., P/N 4200-9622
2. Fuse, Slo-Blow, Bussman, MDL, 0.1 A

1.5 ACCESSORIES AVAILABLE.

1.5.1 General.

Table 1-3 lists the accessories and related equipment available.

1.6 PATCH CORDS AND ADAPTORS.

The front- and rear-panel INPUT connectors are standard 3/4-in. -spaced binding-post pairs that accept banana plugs, standard telephone tips, alligator clips, crocodile clips, spade terminals, and all wire sizes up to number 11 (Figure 1-2). All-copper wires (and connectors if any are used) are recommended when interconnecting mV or pA sources. A Tektronix Type P6028 input probe, an available accessory, is recommended for other measurement ranges. The rear panel RECORDER jack accepts Switchcraft type 440 phone plugs.

Table 1-2
REAR-PANEL CONTROLS and CONNECTORS

Name	Type	Function
BATTERY INPUT	Four-prong male connector (Accepts GR Type 1538-P3 Battery and Charger)	Connection for an external 24-V dc battery supply, as an alternate means for powering the instrument.
RECORDER	Telephone jack	Output for a recorder or other monitoring device. One side of the jack is connected to the INPUT LO binding post. The polarity of the recorder signal is changed by operating the POLARITY switch.
INPUT	Three 3/4-in.-spaced jack-top binding posts	Alternate input connection for the signal to be measured. The binding posts are in parallel with the front-panel INPUT terminals. The gray-colored post is connect to the circuit ground directly and can be connected to the chassis via a ground link to the metallic post, which is connected to the chassis and, via the power cord, to ground.
Power connector.	Three-wire power-plug receptacle	Connection for 100- to 125-V or 200- to 250-V, 50- to 60-Hz line voltage.
100-125, 200-250, 50-60 Hz	Switch, slide, screwdriver adjust	When set to 100-125, the instrument will operate on 100- to 125-V line voltage. When set to 200-250, the instrument will operate on 205- to 250-V line voltage.



Table 1-3
ACCESSORIES AND RELATED
EQUIPMENT AVAILABLE

Name	Type or Part No.	Function
Rack Adaptor Set		Rack-mount instrument.
Battery and Charger	GR Type 1538-P3	External 24-V power supply source (see Appendix).
Input Probe and GR Type 274-QBJ Adaptor.	Tektronix Type P6028 probe package and GR adaptor. (1807-P1 Probe, P/N 1807-9601)	Aid for routine voltage and current measurements (not for extremely low levels). Type 274-QBJ adapts binding posts to BNC.
Standard Resistors	GR Types 1440-9601 and 1440-9611	External shunts for measuring currents to 300 mA (1440-9611) and to 1A (1440-9601).
Adaptor Cable	GR Type 1560-P95	Provide phone plug-to-jack-top binding posts (3/4-in.-spaced) recorder connection (36 in. long).
Adaptor	GR Type 777-Q1	Phone plug and two jacks with 3/4-in. spacing, for recorder connection.

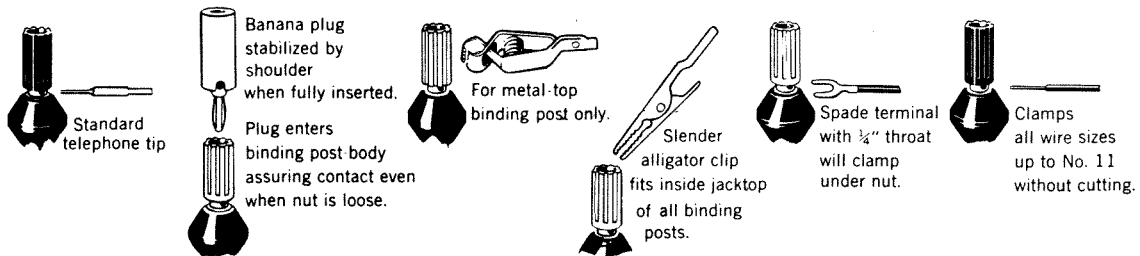

Figure 1-2. Methods of connection to the binding post terminals.

Installation—Section 2

2.1 INSTRUMENT LOCATION	2-1
2.2 DIMENSIONS	2-1
2.3 ELECTRICAL CONNECTIONS	2-1
2.4 BENCH MOUNTING	2-1
2.5 RACK MOUNTING	2-2

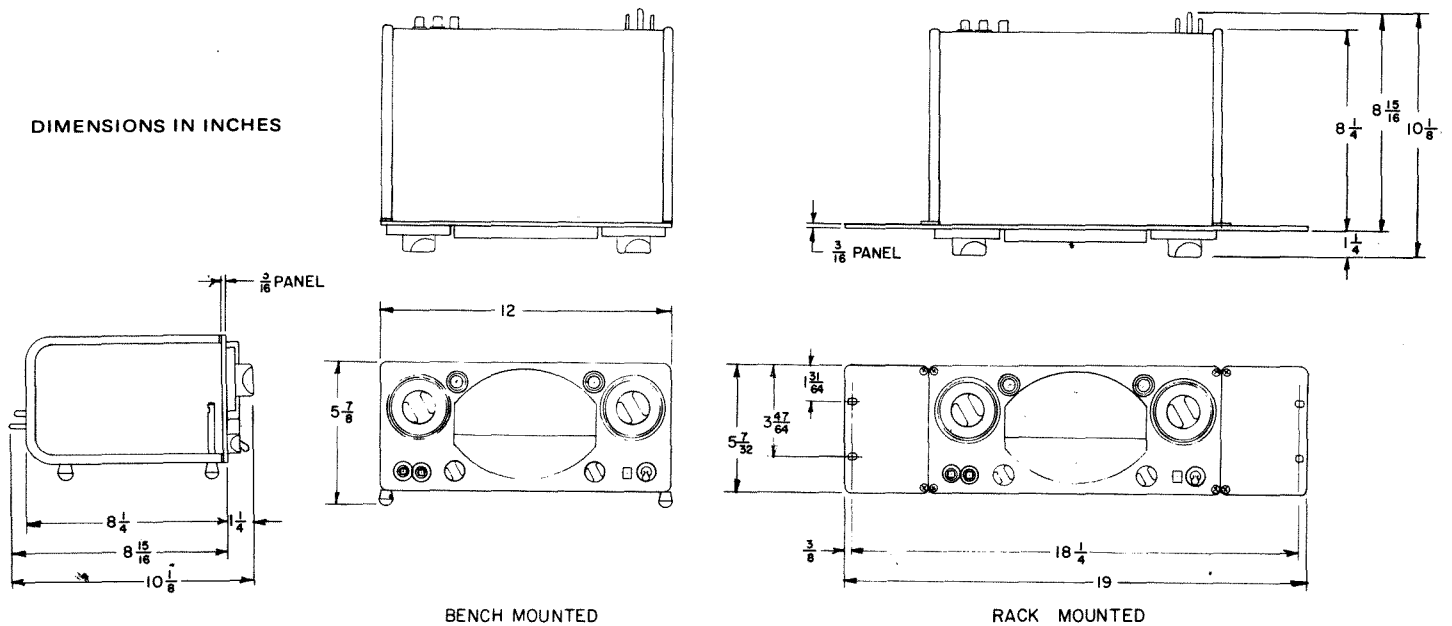

Figure 2-1. Outline of the 1807 in bench and rack-mount configurations.

2.1 INSTRUMENT LOCATION.

For effects of temperature on operation, refer to Section 3.

2.2 DIMENSIONS.

Figure 2-1 is an outline drawing showing over-all dimensions of the 1807 in bench and rack configurations.

2.3 ELECTRICAL CONNECTIONS.

The 1807 operates on 50- to 60-Hz line voltages of either 100 to 125 V or 200 to 250 V, depending on the setting of the two-position switch on the rear panel.

Set the line-voltage selector switch to the desired setting, using a narrow-blade screwdriver, and connect the three-wire power cord to the line and the male power connector on the rear panel.

The instrument can also be operated from a 24-V battery. The GR Type 1538-P3 Battery and Charger is recommended for this type of operation. Both the line power and battery power can be connected to the instrument simultaneously. The instrument will then operate from the source that supplies the higher effective voltage. Refer to the Appendix at the rear of the manual for battery-connection instructions.

2.4 BENCH MOUNTING.

To set the instrument in a tilted position, pull down the front feet and turn the legs to lock them in position.

2.5 RACK MOUNTING.

With the Rack Adaptor Set (P/N 0480-9832), the portable bench model can be converted for use in an EIA-standard 19-in. relay rack with universal spacing. Table 2-1 lists the parts included in the Rack Adaptor Set.

Mount the instrument as follows (see Figure 2-2):

a. Remove the rubber feet (A); retain the screws.

NOTE

The legs on the front feet of the 1807 are treaded into the feet.

b. Remove and retain the screws (C) that secure the front panel to the aluminum end frames.

CAUTION

Do not lose the spring and pin held in the threaded-bottom-end of each frame. The pins may pop out when the screws are removed.

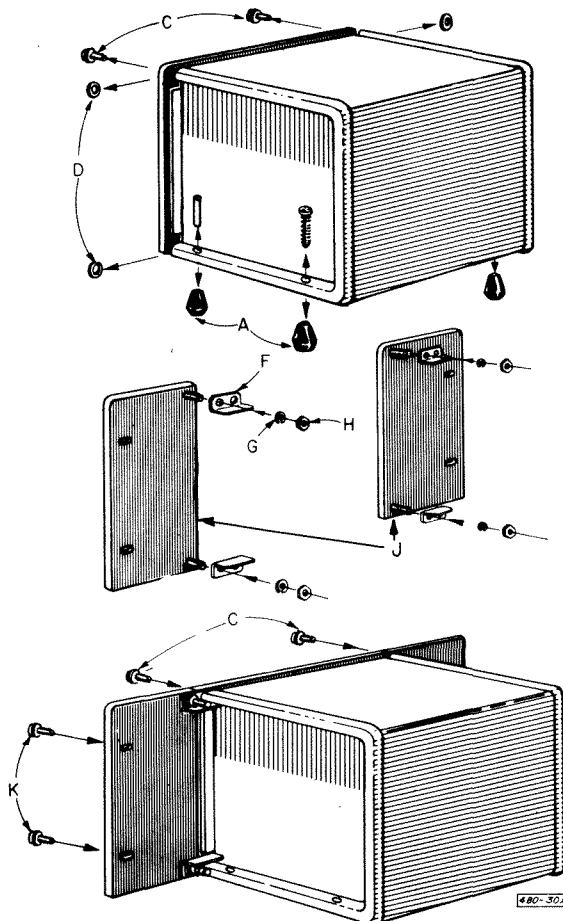

Figure 2-2. Method of rack mounting the 1807.

c. Remove the spacers (D) between the front panel and end frames.

d. Install two brackets (F) on each adaptor panel (J) using screws (C), lockwashers (G) and nuts (H) provided. The springs and pins should be retained in the threaded ends of the frames, to prevent their loss.

e. Attach the panels to the instrument with the front-panel screws (C) remove in step b. The protruding brackets on the adaptor panel slide into the space left by removal of the spacers (D).

f. To reconvert the instrument to a bench-mount unit, reverse the rack mounting procedure. It may be necessary, however, to remove the end frames when reinstalling the rigid (metal shafts) front feet. The end frames slide off the side panels. Make sure the spring and pin are inserted in the bottom threaded hole on the frame, with the spring inserted first. Push the pin back with a pointed object and insert the rigid foot through the frame, threaded end first; screw the feet on to the shafts.

Table 2-1
PARTS INCLUDED IN THE RACK
ADAPTOR SET, P/N 0480-9832

Fig. 2-2 Ref.	No. Used	Item	GR Part No.
J	2	Adaptor Plate	0480-8723
—	1	Hardware Set includes:	0480-3240
F	4	Bracket	—
C	8	Screw, No. 10-32 1/2-in., with fiber washer	—
—	1	Nut Plate (not used)	—
H	8	Nut, hex, No. 10-32	—
G	8	Lockwasher, No. 10	—
K	4	Screw, No. 10-32 1/2-in., with nylon cupwasher	—

Operation – Section 3

3.1 GENERAL INSTRUCTIONS	3-1
3.2 TURN-ON	3-1
3.3 VOLTAGE MEASUREMENTS	3-2
3.4 CURRENT MEASUREMENTS	3-2
3.5 USE WITH A RECORDER	3-2
3.6 APPLICATIONS	3-2

CAUTION

Do not apply more than 150 V on the 1.5-V range or below. Make sure that the RANGE switch is set to μV - kV before a voltage to be measured is applied to the instrument. Do not apply more than 10 V to the instrument when the RANGE switch is set to any nA or mA range; use external shunts when current greater than 10 mA is applied to the instrument.

3.1 GENERAL INSTRUCTIONS.

Observe the following general rules:

1. Avoid large temperature gradients across the instrument, to minimize thermal electromotive forces (emf's) on low-level measurements.

2. Allow 15 minutes for instrument warmup for microvolt and picoampere measurements, to avoid thermoelectric voltages.

3. Adjust the meter-zero occasionally, to calibrate the sensitive ranges (15 μV – 1.5 mV, 15 pA – 1.5 nA, and 15 nA – 1.5 μA , the last three groupings on the RANGE switch). Short-circuit the input terminals, set the outer INTERPOLATION OFFSET switch to INTERPOLATE, the INTERPOLATION OFFSET rotary switch to 0, and use the ZERO adjustment. It is not necessary to adjust the meter-zero for ranges above 1.5 mV, since the effect of the adjustment is negligible on any range above 1.5 mV.

The following practices are suggested:

1. Use all-copper wires when interconnecting microvolt or picoampere sources. The INPUT binding posts are gold-plated copper to minimize thermoelectric voltages, which are a main source of errors when measuring microvolts dc.

2. Set the FILTER switch to IN to measure voltages or currents in the microvolt or picoampere ranges.

3. If a static charge on the meter cover is suspected, wet the cover with an anti-static solution, Weston Statnul* or equivalent.

3.2 TURN-ON.

The instrument can be operated from 115- or 230-V ac, 50-60-Hz line voltage, or from a 24-V battery. The battery and the line voltage can be connected to the instrument simultaneously, and the instrument will operate from the source that supplies the higher effective voltage. Perform the following steps to turn on the instrument:

a. If line voltage is used to operate the instrument, set the line-voltage selector switch to the line-voltage used and connect the instrument to the power line, using the power cable supplied. If battery power is to be used, connect the battery to the rear-panel BATTERY connector.

b. Set the outer and inner RANGE switches to the range and type of source being measured. Observe the cautions specified at the beginning of this section.

c. Set the outer INTERPOLATION OFFSET switch to DIRECT.

d. Set the POLARITY switch to the appropriate position.

e. Connect the source to be measured to the front- or rear-panel INPUT terminals. The Tektronix type P6028

*Registered trademark of Weston Instruments, Inc.



Voltage Probe, available as an accessory, is useful to measure voltages in the order of 1 mV and above and currents that are not exceedingly small. The GR Type 274-QBJ Adaptor, supplied with the probe, converts the front- or rear-panel 3/4-in.-spaced binding posts to a type-BNC which will accept the voltage probe. The probe should not be used for low-level signals, since thermoelectric voltages may be induced. Refer to paragraph 3.1 for information on interconnecting microvolt or picoampere sources.

f. For "floating" or bridge measurements, disconnect the shorting link between the two LO terminals on the rear panel, even if using the front-panel INPUT terminals.

g. Set the POWER switch to POWER; refer to the appropriate paragraph for instructions on performing various measurements (voltage and current) and recording.

3.3 VOLTAGE MEASUREMENTS.

CAUTION

Set the outer RANGE switch to μV - kV before applying the voltage to be measured to the instrument. For voltages above 150 V, make sure the inner RANGE switch is set to 1.5 V or above.

a. Set the RANGE switch to approximately the range of the measured voltage, the outer INTERPOLATION switch to DIRECT, and POLARITY switch to the appropriate position, as stated previously in the turn-on procedure.

b. Read the voltage on the meter scale, taking into account the position of the RANGE switch. If greater accuracy is required, perform steps c and d.

NOTE

For maximum accuracy when using the interpolation-offset feature on the 150- μV and 1.5-mV ranges, check the meter zero with the INPUT terminals short circuited and the INTERPOLATION OFFSET ring dial set to INTERPOLATION and the knob switch set to 0; adjust the meter zero if necessary.

c. Set the INTERPOLATION OFFSET inner switch to the first digit of the meter reading if the reading is below 1.0, or to the first two digits if the reading is between 1.0 and 1.5. For example, if the meter reading is 0.27, set the switch to 0.2. If the meter reading is 1.27, set the switch to 1.2.

d. Set the outer INTERPOLATION OFFSET switch to INTERPOLATE. The position of the inner INTERPOLATION OFFSET switch indicates the first digit, or digits, of the reading, and the meter indicates the following digits. For example, if the inner INTERPOLATION OFFSET switch is set to 0.2 and the meter indication is 0.72 the

significant figures are 272. If the switch is set to 1.2 and the meter reading is 0.51 the significant figures are 1251. To obtain the actual value, however, multiply the meter reading by 0.1 and add it to the setting of the inner INTERPOLATION switch (e.g., $(0.51)(0.1) = 0.051 + 1.2 = 1.251$).

For use with a recorder, refer to paragraph 3.5.

3.4 CURRENT MEASUREMENTS.

CAUTION

Do not apply current greater than 10 mA without external shunts, and voltage greater than 10 V in any of the nA to mA ranges.

The RANGE switch provides two overlapping current ranges. Either range can be used to measure the unknown current, if it is within the overlap of both ranges; however, the pA - nA range has a 1-M Ω shunt, whereas the nA - mA range has a 1-k Ω shunt.

Proceed as follows:

a. Set the RANGE switch to approximately the range of the measured current, the other INTERPOLATION switch to DIRECT, POLARITY switch to appropriate position, and FILTER switch to IN, if the current to be measured is in the picoamp to microamp range.

b. Read the current on the meter, taking into account the position of the RANGE switch. If greater accuracy is required, perform steps c and d of the previous paragraph.

3.5 USE WITH A RECORDER.

a. Connect the recorder or other monitoring device to the rear-panel RECORDER jack and adjust the RECORD CURRENT adjustment for the desired recorder response.

b. If the INPUT LO terminal on the rear panel is grounded, do not ground the recorder. No damage will result, but there will be no output for one POLARITY switch position, since one side of the RECORDER jack is connected to the INPUT LO binding post. If necessary, unground the LO binding post or the recorder.

NOTE

The RECORDER CURRENT thumbset adjustment allows adjustment of the RECORDER jack output ± 2.5 V open circuit for full scale reading, ± 1 mA into a 1.5 k Ω max. load.

3.6 APPLICATIONS

3.6.1 General.

Because of its versatility, the 1807 will undoubtedly find applications in physics, biology, and chemistry, as well as in electronics. Thus the applications discussed below should not be interpreted as being the prime uses of this instrument.

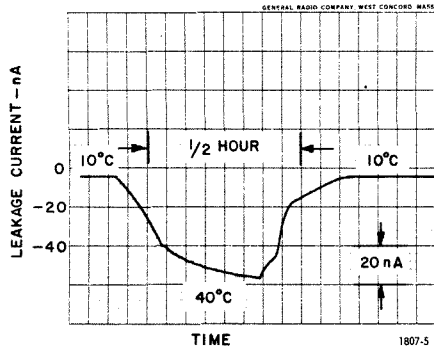

Figure 3-1. Recording of the leakage current for a Type 1N3604 diode cycled through a temperature change of 10°C to 40°C.

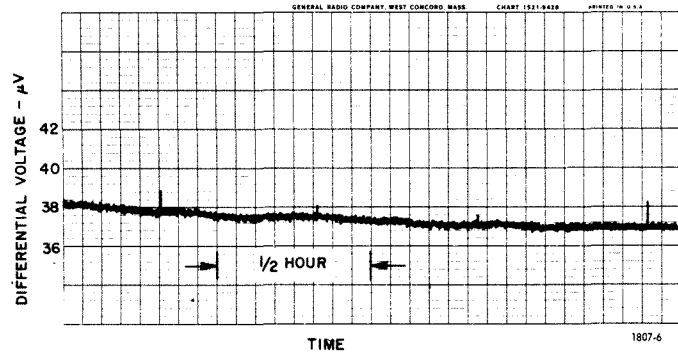

Figure 3-2. Recording of the drift of the voltage difference between two unsaturated standard cells at 25°C.

3.6.2 Diode or Transistor Matching.

Quite often it is desirable to match a pair of diodes for leakage current or forward voltage drop (emitter-to-base voltage in case of transistors). The 1807 can be used to measure the forward voltage drop with a high degree of accuracy (using the interpolation feature) and the reverse leakage current with high sensitivity. Figure 3-1 shows a recording of leakage current for a type 1N3604 diode cycled through 10°C to 40°C.

3.6.3 Low-Level Differential Measurements.

For comparison of various standard cells (e.g., saturated versus unsaturated), one is interested in making dc differential measurements of a few hundred microvolts with accuracies of about 1 or 2 μV. Figure 3-2 shows a recording of differential measurements for two unsaturated standard cells. This recording, taken over a two-hour period, shows that the cells differed by 38.1 μV at the beginning of the test and by 36.8 μV at the end of two hours. The test temperature was 25°C.

3.6.4 Temperature Measurements.

Figure 3-3 is a recording of the thermoelectric voltages generated by temperature difference between two points in a non-air-conditioned room. A copper-constantan thermocouple with a temperature coefficient of 39 μV/°C was used in this test. The recording, taken over a one-hour period, shows the thermoelectric voltage between the two junctions of the thermocouple to vary between +8 μV and -28 μV. Thus, the temperature variation is concluded to be about 0.9°C.

3.6.5 High-Value Resistance Measurements.

The low-current sensitivity and the high accuracy of the 1807 make it suitable for very-high-resistance measurements. Figure 3-4 is a typical setup for such measurements. A nominal current i of 410 pA at 50°C was measured with the 1807, using the interpolation feature (Figure 3-5). Thus, the value of R_x at 50°C is calculated to be $9.75 \times 10^{10} \Omega$. As the temperature was dropped to 0°C, the current measured by the 1807 decreased to 376 pA. The resistance of R_x at 0°C, therefore, is $1.06 \times 10^{11} \Omega$.

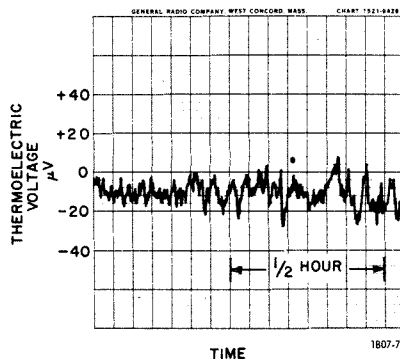

Figure 3-3. Recording of the thermoelectric voltage generated by a thermocouple.

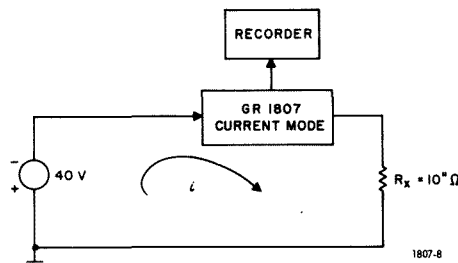

Figure 3-4 Test set-up for measuring unknown resistor R_x .

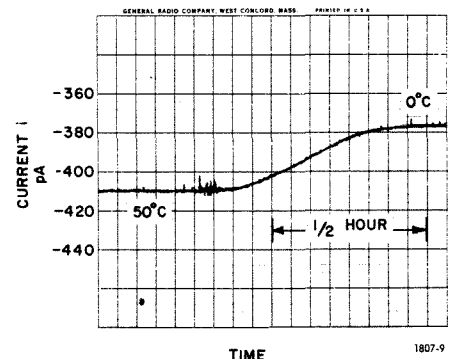

Figure 3-5. Recording showing the change in current i (Figure 3-4) as the ambient temperature changes from 50°C to 0°C.

Theory – Section 4

4.1 INTRODUCTION	4-1
4.2 DETAILED DESCRIPTION	4-3

4.1 INTRODUCTION.

The 1807 operates on the principle of converting low-level dc signals to ac, amplifying the signals, reconvert- ing the signals to dc, applying the signals to a meter that indicates the amplitude of the signal. The instrument's interpolation-offset feature allows the user to read the difference between two signals (one signal produced inter- nally) to within 0.1 % of the reading plus 0.1 % of full-scale accuracy. When an interpolation-offset switch is set to the appropriate position, a calibrated voltage equal to the most significant digit(s) of the unknown input signal is subtracted from the signal; the difference is then read on the meter. giving accuracies usually associated with digital techniques.

Figure 4-1 shows a simplified block diagram of the 1807. The input signal is applied to a photochopper, which converts the dc signal to ac. The ac signal is amplified and converted to dc, amplified again by a dc amplifier, and applied to a meter and to a recorder circuit, for driving an externally connected recorder.

The signal is also fed back to the input photochoppers. If the signal is interpolated, a calibrated voltage equal to the most significant figure(s) of the unknown signal is sub- tracted from the input when the INTERPOLATION con- trols are set to the appropriate positions.

High input impedance is achieved by high loop gain in the amplifiers and the high impedance of the series-shunt cadmium-selenide (CdSe) photoconductors at the input.

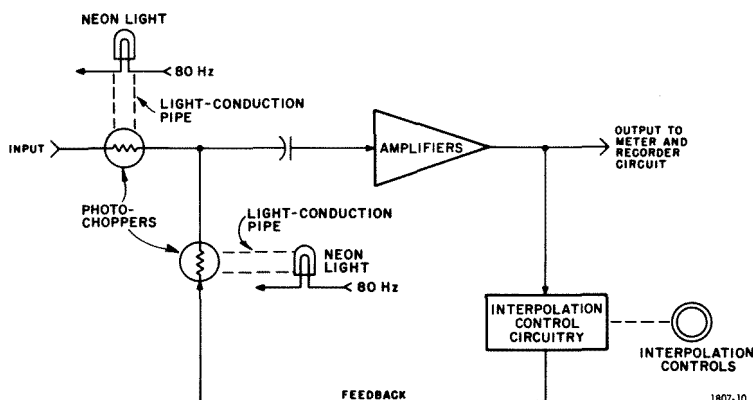

Figure 4-1. Simplified block diagram of the 1807.

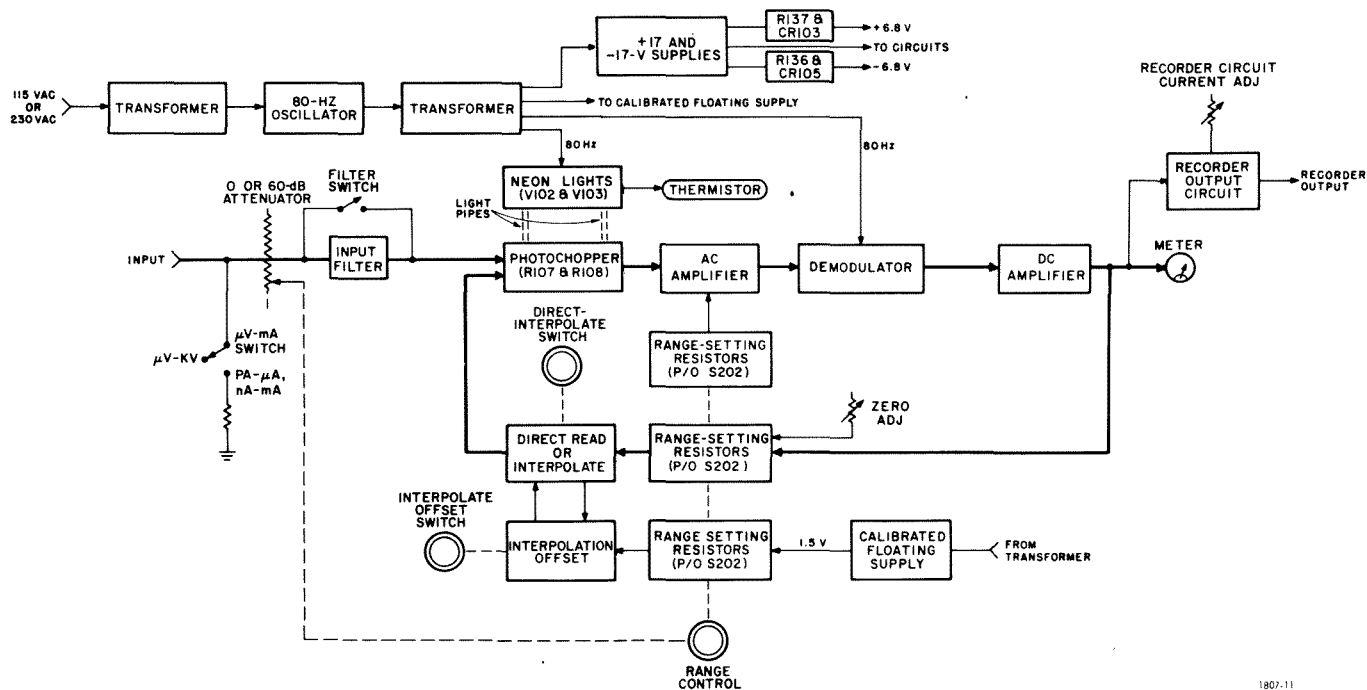

Figure 4-2. Detailed block diagram of the 1807.

Figure 4-2 shows a detailed block diagram of the 1807. As shown, the 1807 consists of the following circuits:

1. Current or voltage selector switch ($\mu\text{V} - \text{mA}$)
2. Zero to 60-dB attenuator
3. Input filter and switch
4. Photochopper, including neon lights and light pipes
5. Ac amplifier
6. Demodulator
7. Dc amplifier
8. Meter
9. Recorder-output circuit
10. Range-setting resistors that are a part of the RANGE switch
11. Calibrated floating supply
12. DIRECT-INTERPOLATE and INTERPOLATION OFFSET switches and circuits
13. Transformers and power supplies.

The setting of the μV -mA RANGE selector at the input determines the type of measurement to be made, either voltage or current. If the input signal is in a range above 1.5 V (15, 150, and 1500 V), the signal is switched through a 60-dB attenuator when the appropriate range is selected with the RANGE control. The FILTER switch allows the suppression of noise superposed on the dc voltage or current, by steering the signals through a filter network. The input dc voltage or current is then applied to the photochopper circuit.

The photochopper circuit converts the dc signal to ac. Neon bulbs, connected through light-conduction pipes to photoconductors and flashing at an 80-Hz rate, activate the

photoconductors, causing the dc signal to be converted to ac. The ac signal is amplified by the ac amplifier, reconverted to dc by the demodulator, and amplified again by the dc amplifier. The signal is applied to the meter, which provides an indication of the magnitude of the current or voltage. The signal is also applied to the recorder output circuit, to drive an externally connected recorder.

A feedback loop originating at the output of the dc amplifier is fed back through range-setting resistors to the photochopper circuit directly, if the DIRECT-INTERPOLATE control is set to DIRECT. The feedback signal, applied to the appropriate range-setting resistor(s), provides a high loop gain in the ac amplifier, contributing to the high input impedance of the 1807. If the measurement is to be interpolated, the feedback signal is fed through an interpolation-offset network when the DIRECT-INTERPOLATE switch is set to INTERPOLATE.

The calibrated floating power supply is connected to the interpolation-offset network through what is essentially a voltage-divider network of range-setting resistors. The resistors, selected by the setting of the RANGE control, establish the appropriate voltage range. This voltage is then applied to the interpolation-offset resistor network — also a resistor-divider network — which, under control of the INTERPOLATION OFFSET control, introduces a voltage into the feedback circuit corresponding to the most significant digit(s) selected with the INTERPOLATION OFFSET control. This calibrated voltage (or current) subtracts from the input, causing the meter to read less by the amount of interpolation offset selected.

The line-voltage transformer drives an 80-Hz square-wave oscillator. The output of the oscillator is applied to the primary of another transformer. The transformer's secondary feeds the calibrated floating power supply, +17 and -17-V power supplies, and the neon bulb-thermistor circuit. The secondary also feeds an 80-Hz square wave directly to the demodulator. The power supply, in turn, furnishes voltages to various circuit components and also feeds two reference-diode circuits which produce +6.8 V and -6.8 V for various circuit components.

The thermistor minimizes the changes in the impedance of the instrument over operating temperatures.

4.2 DETAILED DESCRIPTION.

4.2.1 General.

For the following discussion, refer to Figures 6-3 and 6-4.

4.2.2 μV -mA RANGE Control.

The μV -mA portion of the RANGE control permits the measurement of current, by connecting either a 1-M Ω (R201) or 1-k Ω (R202) shunt to the input, for the pA- μA and nA-mA ranges, respectively.

4.2.3 Attenuator.

The attenuator is comprised of resistors R109, R110, and R222 to R224. When measurements in the 15-V, 150-V, and 1.5-V ranges are being made, and the RANGE control is set to these respective ranges, the input signal is applied to the attenuator and is attenuated 60 dB. R110 allows calibration of the instrument.

4.2.4 Filter.

The input filter is an RC low-pass filter with a cutoff frequency of 1.5 Hz at the input. The filter suppresses any noise that may be superposed on dc voltages and currents. For faster response time, the filter can be switched out by the front-panel FILTER switch.

4.2.5 Photochoppers.

The photochoppers, R107 and R108, convert the dc signal to ac. The frequency of chopping is controlled by the 80-Hz oscillator, whose output is applied to transformer T502. Two neon bulbs, V102 and V103, are connected to the transformer secondary. The bulbs are connected to flash alternately on the positive and negative cycles of the 80-Hz signal. Light-conduction pipes direct the light from the flashing bulbs to photoconductors mounted at the end of pipes. The flashing bulbs activate the photoconductors, converting the dc signal applied to the photoconductors to ac.

Thermistor R508 in the neon-bulb circuit keeps the impedance of the instrument constant for various operating temperatures. This is possible because the photoconductors have a positive coefficient and their impedance increases as the temperature increases. The thermistor also has a positive temperature coefficient and tends to reduce the

current in the neon bulbs, reducing the light of the bulbs. The reduced light reduces the efficiency of the photoconductors, hence, the input impedance. Conditions reverse when the temperature is lowered.

V101, a neon bulb in the output circuit, is a protective device that prevents damage to the instrument if the input is overloaded.

4.2.6 Ac Amplifier.

The ac amplifier is feedback type comprised of Q101 through Q104. The gain of the amplifier is determined by the setting of the RANGE switch, which controls the resistance in the emitter circuits of Q101 and Q104. The gain can be varied from approximately two on the least-sensitive range to about 2000 on the 15- μV and 150- μV ranges. Since the gain of each circuit following the ac amplifier is constant, the loop gain of the instrument is constant and equal to approximately 300 on all ranges, except the most sensitive range, where the loop gain is 30.

ZERO adjustment, R401, is connected across point F at CR101 and D at Q101 on the amplifier and is used to zero the meter. Q101 is specially selected for low-noise applications and provides high impedance to the photochoppers preceding it.

CR102 limits the collector bias voltage for Q102 to Q104 to less than 10 V. CR101 limits the Q101 collector voltage to less than 6.8 V.

4.2.7 Demodulator.

The demodulator, Q105, is operated in an inverted mode. An 80-Hz signal from point E on the secondary of T502 is applied at point E to drive the modulator, reconverts the ac signal to dc.

4.2.8 Dc Amplifier.

The dc amplifier consists of transistors Q106 through Q109. Q106 and Q107 comprise a differential amplifier, with approximately equal collector currents and voltages, minimizing any offset introduced by these transistors. A positive voltage at the base of Q106 causes Q106 to conduct more and Q107 to conduct less. The voltage at the base of Q108 then rises, causing it to conduct less. This in turn causes Q109 to conduct less, increasing the output voltage at its emitter. Feedback from Q109 to Q106 converts the amplifier to an integrator. Adjustment R132 in the differential-amplifier circuit provides correction for any offset produced by Q106 and Q107.

The amplifier's gain is approximately 50 dB at frequencies of .007 Hz and below. The gain drops at a rate of 6 dB-per-octave until a 5-Hz frequency is reached, at which the gain is 0 dB.

4.2.9 Meter.

The meter scale is logarithmic above 10% of full scale and linear below 10% of full scale. The zero is offset by about 20°, to allow readings about zero and still preserve most of the meter movement for higher resolution. The front-panel POLARITY switch allows measurements on

either region of the meter. R140 allows for correction for the full-scale deflection of the meter and CR401 protects the meter against overloading.

4.2.10 Recorder Circuit.

The recorder circuit is connected directly to the output of Q109. Series resistor R135 prevents damage to the instrument for any load, including a short circuit, connected in series with R402, at the output. R140, the RECORD CURRENT adjustment on the rear panel, allows adjustment of the level of the output at the RECORDER jack (± 2.5 V open circuit) for full meter deflection, ± 1 mA into a $1.5\text{-k}\Omega$ recorder.

4.2.11 Range-Setting Resistors.

The output of the dc amplifier is fed back to photoconductor R108 through the range-setting resistors (starting with R213), the INTERPOLATION control network, and R116. The first group of range-setting resistors establishes a voltage corresponding to the voltage range. The arm of R401, the ZERO adjustment, connects to this group of resistors. The output of this group of resistors is fed directly to R116 and R108, if the INTERPOLATION OFFSET control is set to DIRECT. If the reading is to be interpolated, the floating power supply is connected to a group of range-setting resistors (starting with R203) when the INTERPOLATION OFFSET control is set to INTERPOLATION. These resistors establish voltages corresponding to the nine voltage ranges (1.5 V maximum).

The output of the range-setting resistors is then applied to a voltage-divider network associated with the INTERPOLATION controls; this voltage-divider network consists of resistors R301 through R307. Figure 4-3 illustrates the operation of the network.

As shown in Figure 4-3, the network acts as a battery-voltage supply, introducing a calibrated voltage into

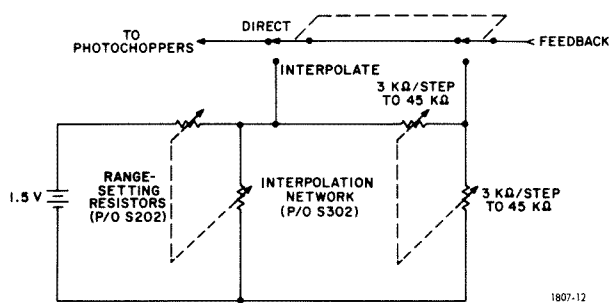

Figure 4-3. Range-setting and interpolation divider network.

the feedback loop that "bucks", or subtracts, from the voltage in the feedback loop when the reading is interpolated. The 1.5-V is supplied by the calibrated voltage supply. The range-setting resistors establish a voltage proportional to the selected range. The voltage is applied to the interpolation network, which consists of a voltage divider with divisions that can be varied in $3\text{-k}\Omega$ steps.

When the INTERPOLATION OFFSET 16-position rotary switch is set to the first digit, or first two digits, of a direct meter reading, the divider network causes a calibrated voltage corresponding to the selected switch position (or significant figure(s) of the unknown) to be placed in the feedback loop, "bucking" the feedback voltage and subtracting from the input. The difference is then read on the meter.

4.2.12 Calibrated Floating Supply.

The calibrated floating supply is derived from a very stable, 9.4-V Zener diode, CR107. The bridge circuit of the supply compensates for the series impedance of the diode; therefore, the series resistance of the diode is corrected for line-voltage variations. R102 provides for adjustment of the output and for calibration of the instrument. The output of the supply is 1.5 V.

4.2.13 Oscillator.

The 80-Hz square-wave oscillator is turned on when the instrument is energized, and is free running. The output is fed to the primary of T502 to drive the power supplies and flash the neon bulbs associated with the photochoppers. The 80-Hz signal is provided at point E on the secondary of T502 to drive the demodulator.

4.2.14 Transformers and Power Supplies.

The instrument can be powered by $50\text{-}60\text{-Hz}$ line voltages of either $100\text{-}125$ V or $200\text{-}250$ V, or by an external battery. Both the battery and the line voltage can be connected simultaneously, and the instrument will operate from the higher effective source. When the POWER switch is turned on, and the instrument is operating on line voltage, the half-wave rectifiers comprised of CR503 and CR504 supply a dc voltage that turns on the oscillator. If a battery is used, it also supplies a dc voltage when the POWER switch is turned on. The power supply with the bridge circuit consisting of diodes CR505 to CR508, supplies $+17$ V, $\pm 10\%$ at output A of the supply and -17 V, $\pm 10\%$ at output B. These voltages are fed to the circuits and to Zener diodes CR103 and CR105, which provide reference voltages of $+6.8$ V and -6.8 V, respectively, for various circuit elements.

Service and Maintenance—Section 5

5.1	GR FIELD SERVICE	5-1
5.2	INSTRUMENT RETURN.	5-1
5.3	MINIMUM PERFORMANCE STANDARDS	5-1
5.4	PART LOCATIONS.	5-5
5.5	DUST COVER REMOVAL-REPLACEMENT.	5-5
5.6	SERVICING ETCHED-CIRCUIT BOARD	5-5
5.7	TEST POINTS	5-6
5.8	CALIBRATION.	5-6
5.9	TROUBLE ANALYSIS	5-6
5.10	REPLACEMENT OF CONTROLS	5-6
5.11	LAMP-REPLACEMENT	5-10
5.12	PHOTOCHOPPER REPLACEMENT	5-10
5.13	FRONT-PANEL FINISH	5-10

5.1 GR FIELD SERVICE.

Our two-year warranty attests the quality of materials and workmanship in our products. When difficulties do occur, our service engineers will assist in any way possible. If the difficulty cannot be eliminated by use of the following service instructions, please write or phone our Service Department (see last page), giving full information of the trouble and of steps taken to remedy it. Be sure to mention the serial, type and ID numbers of the instrument.

5.2 INSTRUMENT RETURN.

Before returning an instrument to General Radio for service, please write or phone our Service Department or nearest District Office, requesting a "Returned Material Tag." Use of this tag will ensure proper handling and identification. For instruments not covered by the warranty, a purchase order should be forwarded to avoid unnecessary delay.

5.3 MINIMUM PERFORMANCE STANDARDS.

5.3.1 General.

The following paragraphs contain information to determine that the 1807 is performing within specifications. The procedures enable instrument-standards laboratories and equivalently equipped service facilities to perform checks at periodic intervals and after repair, to determine that the instrument is operating properly. These procedures are bench checks that require the use of only front-panel controls and externally available test points (i.e., instrument disassembly is neither required or recommended).

Table 5-1 lists the recommended test equipment for a minimum performance check, adjustment and calibration procedures, and trouble analysis.

The following checks are included, to determine that the instrument is operating properly:

1. Noise
2. Accuracy and recorder output
3. Current range
4. Polarity
5. Input impedance
6. Input current
7. Dc common-mode rejection
8. Ac common-mode rejection.

5.3.2 General Instructions.

Table 5-1 lists the test equipment required for the minimum-performance standards checks, calibration procedures, and trouble analysis. Refer to Section 3 for interconnection instructions, when making checks on various measurement ranges. Wires for interconnecting the voltage divider must be all-copper to keep thermal emf's to minimum. It is suggested that all checks be made in an air conditioned room, if possible.

5.3.3 Noise Check.

Perform the following steps to check for noise conditions:

- a. Set the 1807 controls as follows:

DIRECT-INTERPOLATE	DIRECT
FILTER	IN
POLARITY	+
RANGE (ring dial)	nA - mA
RANGE (knob dial)	15 nA



Table 5-1
TEST EQUIPMENT

Type	Requirement	Recommended*
Oscillator	60-Hz, 16-V pk-pk sinewave output	GR 1310 Oscillator
Decade Resistor	.05 % accuracy, four decades	GR Type 1434-N Decade Resistor
Voltage Divider	Voltage ratios from .00001 to 0.10000, 10 kΩ input resistance	GR Type 1455-B Decade Voltage Divider
Adjustable dc power supply	Accurate dc voltages of 1.0, 10.0, 100 and 600 V	GR Type 1822 Digital Voltmeter Calibrator
Oscilloscope	General purpose	Tektronix Type 504
Digital Voltmeter	100μV sensitivity, accuracy .01 % of full scale	Hughes Type 5100
Volt-Ohm-Milliammeter	General purpose	Triplet Type 630-NA
1-kΩ & 1-MΩ resistance standards	0.1% accuracy	GR Type 1440
200-MΩ resistance standard	5% accuracy	—
All-copper inter-connecting wires	—	—
Patch cords	Refer to paragraph 1.6	—

*Or equivalent

b. Connect the instrument to the line-voltage source and turn on the instrument according to Section 3; no input signal is used in this check.

c. Adjust the meter-zero using the ZERO adjustment on the front panel and observe that the rapid pk-pk fluctuation of the meter pointer is less than .05 (equivalent to 0.5 μV) for at least 95% of the time.

5.3.4 Accuracy and Recorder-Output Check.

Perform the following steps to check the instrument's accuracy and recorder output:

a. Make the test setup shown in Figure 5-1, using all-copper wires for measurements in the lower ranges. (Refer to Section 3 for interconnection instructions.) Connect the digital voltmeter (DVM) to the RECORDER jack on the rear panel.

b. Set the controls as follows:

- | | |
|----------------------|-------------|
| 1. Type 1822 | |
| OUTPUT | 10 V |
| 2. Type 1455 | |
| Decades to: | .15000 |
| 3. Type 1807 | |
| DIRECT-INTERPOLATE | INTERPOLATE |
| INTERPOLATION OFFSET | 1.5 |
| RANGE (ring dial) | μV-kV |
| RANGE (knob dial) | 1.5 V |
| RECORD CURRENT | Full cw |
| FILTER | OUT |

c. Turn on the instruments and observe that the 1807 reads 0 ± 0.015

d. Decrease the INTERPOLATION OFFSET control setting and the 1455 control settings in 0.1 and .01 steps,

5-2 SERVICE



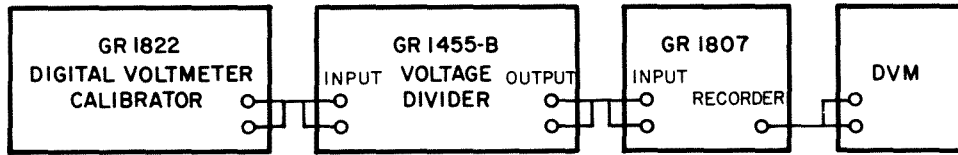

1807-13

Figure 5-1. Accuracy and recorder test setup.

Table 5-2
RECORDER OUTPUT LINEARITY

Step	1455 Control Settings	DVM Reading
1	.15000	$(1.5000 + x) \pm .0015$
2	.12000	$(1.2000 + x) \pm .0012$
3	.08000	$(0.8000 + x) \pm .0008$
4	.04000	$(0.4000 + x) \pm .0004$

x = value obtained in step e.

respectively, and observe that the 1807 meter reads $0 \pm .015$ at each of the INTERPOLATION OFFSET control settings

e. Set the 1807 DIRECT-INTERPOLATE control to DIRECT and the 1455 controls to .00000 and, with the RECORD CURRENT adjustment set full cw, record the DVM reading.

f. Set the 1455 controls to .10000 and observe a 1807 meter reading of 1.0 and a DVM reading of +1.67 V, or higher.

g. Connect a GR 1434-N Decade Resistor in parallel with the 5100 input terminals and adjust the resistor for a 5100 reading of 1.000 plus the reading noted in step e; the 1434-N value should be less than 1.5 k Ω .

h. Check the output linearity as indicated in Table 5-2.

i. Set the 1807 INTERPOLATION OFFSET control to 1.0 and the RANGE ring dial-control to $\mu\text{V-kV}$; check the accuracy of the 1807 according to the steps listed in Table 5-3.

Table 5-3
ACCURACY CHECK

Step	1807 Control Settings		1822 Output	1455 Control Settings	1807 Meter Reading	Notes
	DIRECT-INTERPOLATE	RANGE				
1	DIRECT	15 μV	1.0	.00000	$0 \pm .05$	Set meter zero
2	DIRECT	15 μV	1.0	.00001	$1.0 \pm .11$	—
3	DIRECT	150 μV	1.0	.00000	$0 \pm .005$	Set meter zero
4	DIRECT	150 μV	1.0	.00010	$1.0 \pm .02$	—
5	INT	150 μV	1.0	.00010	$0 \pm .075$	—
6	DIRECT	1.5 V	1.0	—	$1.0 \pm .015$	Remove 1455
7	INT	1.5 V	1.0 V	—	$0 \pm .015$	—
8	DIRECT	15 V	Short-circuited	—	0	Set meter zero
9	DIRECT	15 V	10.0 V	—	$1.0 \pm .015$	—
10	INT	15 V	10.0 V	—	$0 \pm .015$	—

5.3.5 Current Range.

Perform the following steps to check the current range:

a. Connect a 1-M Ω , 0.1% resistance standard between the 1822 and 1807; the DVM and voltage divider should be removed from the test setup.

b. Set the controls as follows:

1. Type 1822	
OUTPUT	1.0 V
2. Type 1807	
DIRECT-INTERPOLATE	INTERPOLATE
INTERPOLATION OFFSET	.5
RANGE (ring dial)	pA- μ A
RANGE (knob dial)	1.5 μ A
FILTER	IN

c. Observe that the 1807 meter reads between $-.02$ and $+0.02$.

d. Set the 1807 RANGE ring dial-control to nA-mA, replace the 1-M Ω resistance standard with the 1-k Ω 1% standard, and observe that the meter reads between $-.02$ and $+0.02$.

5.3.6 Polarity.

Perform the following steps to check the polarity feature:

a. Reconnect the 1822 Digital Voltmeter Calibrator directly to the 1807 with no resistance standard inserted between the units and set the 1807 controls as follows:

DIRECT-INTERPOLATE	INTERPOLATE
INTERPOLATE OFFSET	.1
RANGE (ring dial)	μ V-kV
RANGE (knob dial)	15 V
POLARITY	-
FILTER	OUT

b. Set the 1822 for a -1.0-V output and observe that the 1807 meter reads $-.016$ to $+0.016$.

5.3.7 Input Impedance.

Perform the following step to check the input impedance:

a. Connect a 200-M Ω , 5% resistance standard in series between the 1807 and 1822, set the 1807 DIRECT-INTERPOLATE switch to DIRECT and the RANGE control to 1.5 V, and set the 1822 for a 1.0-V output; observe that the 1807 meter reading is greater than 0.72 V.

5.3.8 Input Current.

Perform the following steps to check the input current:

a. Disconnect all test equipment from the 1807; this test is made without any input.

b. Set the 1807 controls as follows:

DIRECT-INTERPOLATE	DIRECT
RANGE (ring dial)	nA-mA
RANGE (knob dial)	15 nA
FILTER	IN
POLARITY	+

c. Set the meter-zero using the ZERO adjustment.

d. Set the RANGE ring dial-control to pA- μ A and observe that the meter reads between -5 to $+5$ pA; if necessary, set the POLARITY switch to minus(-).

5.3.9 Dc Common-Mode Rejection.

Perform the following steps to check the dc common-mode rejection:

a. Set the 1807 controls as follows:

DIRECT-INTERPOLATE	DIRECT
RANGE (ring dial)	nA-mA
RANGE (knob)	15nA
POLARITY	+
FILTER	IN

b. Remove the shorting link on the 1807 rear-panel LO terminal and set the meter zero using the front-panel ZERO adjustment.

c. Connect the 1822 to the 1807 and apply 600 V between the HI terminal and the chassis (metallic terminal); the 1807 meter should read between -6 and $+6$ nA after the pointer stops fluctuating.

d. Apply the 600 V between the LO terminal on the rear panel and the chassis and observe that the meter reads between -6 and $+6$ nA after the pointer stops fluctuating.

e. Set the output of the 1822 to 1 V and disconnect it from the 1807.

5.3.10 Ac Common-Mode Rejection.

Perform the following steps to check the ac common-mode rejection.

a. Set the 1807 controls as specified in paragraph 5.3.9; the shorting link should remain disconnected.

b. Connect a GR Type 1310 Oscillator, or equivalent, between the HI terminal on the 1807 rear panel and the chassis.

c. Apply a 60-Hz, 16-V pk-pk signal to the 1807 (monitor the signal amplitude with an oscilloscope) and observe that the 1807 meter reads between -8 and $+8$ nA.

d. Repeat step c with the oscillator connected between the LO terminal and the chassis; observe the same reading as in step c.

e. Disconnect the test equipment and replace the shorting link.

5.4 PART LOCATIONS.

Most of the parts and all internal adjustments are on one etched-circuit board in the instrument. (See Figure 5-2.) Other parts, such as the range-setting resistors (see Figure 6-5) and the interpolation-offset resistor-divider network (see Figure 6-6), are on switch wafers. A few parts (CR510, CR502, and CR514) are on the terminal board attached to transformer T501. C501 and C502 are mounted at power connector PL501, and CR401 is mounted at the rear of the meter. Table 5-4 lists the locations of parts according to reference designation groupings.

Table 5-4
PART LOCATIONS

Part No.	Location
100 thru 199	Circuit board
200 thru 299	S201-S202
300 thru 399	S302
400 thru 499	Meter
500 thru 599	Circuit board

5.5 DUST COVER REMOVAL-REPLACEMENT.

To gain access to the parts and internal adjustments, loosen the screws at the rear of the top and bottom dust covers and remove the covers. Remove the plate at the bottom of the etched-circuit board by removing the screws from the plate, if it desired to gain access to the circuit board. The circuit board can be tilted down for access to the parts and components by removing the two screws at the rear of the board and carefully swinging the board down; the front of the board is mounted on pivot blocks.

5.6 SERVICING ETCHED-CIRCUIT BOARD.

The 1807 has one etched circuit board. The board has the parts on one side and the circuitry on the opposite side.

When removing or replacing parts, use a low-heat soldering iron and a small-diameter rosin core solder. Do not subject the parts or boards to excessive or prolonged heat. Parts can be removed by placing the soldering iron on the component lead on the circuit side of the board and pulling up on the lead from the part side. If a part is obviously faulty or damaged, clip the leads close to the part and then remove the leads from the circuit side.

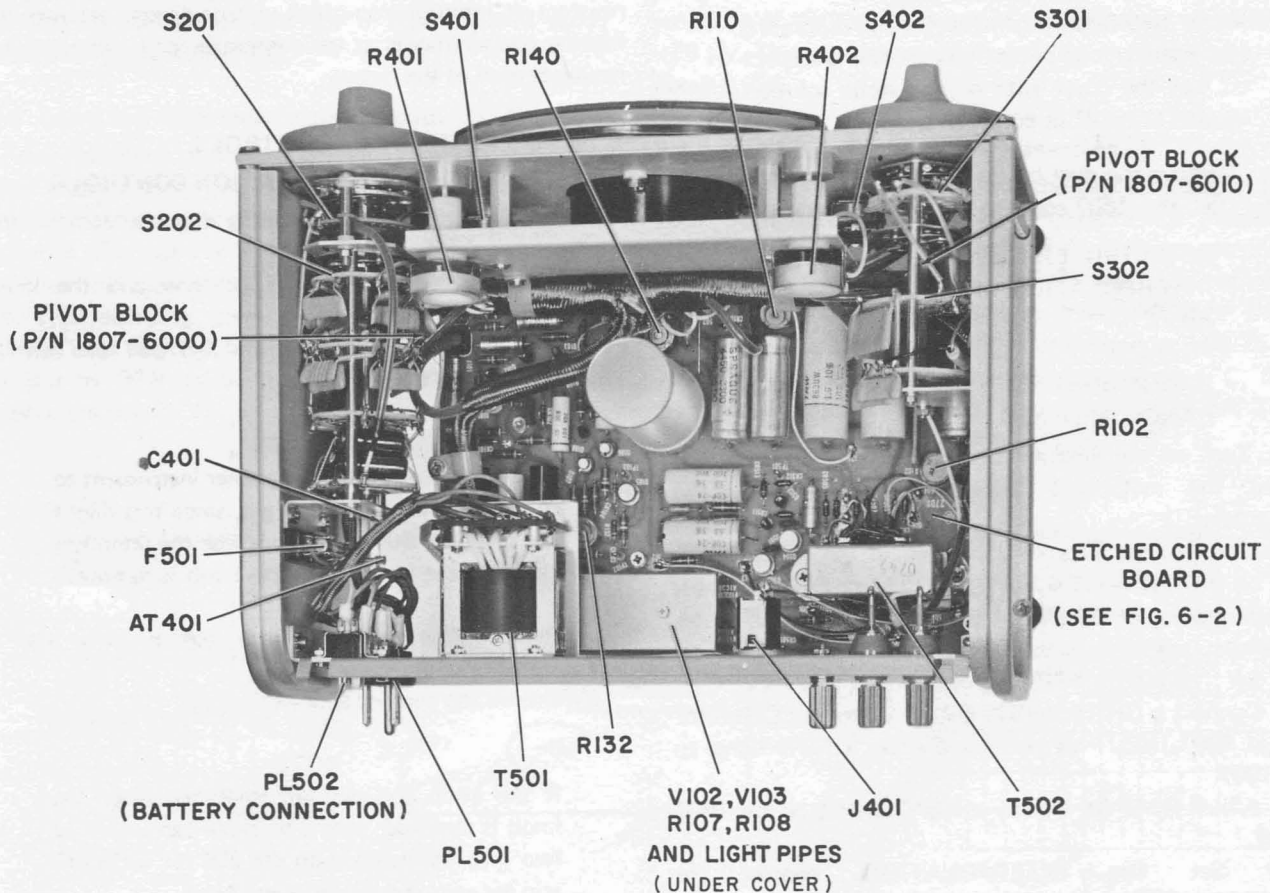

Figure 5-2. Top view of the 1807 with the dust covers removed.

The part lead hole should be cleaned before inserting a new lead. Heat the solder in the hole, quickly remove the soldering iron, and insert a pointed nonmetallic object such as a toothpick, or use a "solder sucker."

Shape the new component leads, insert them in to holes, reheat with the iron, and add solder as necessary to form a good electrical connection. Clean any excess flux from the connection and adjoining area.

5.7 TEST POINTS.

Test points are provided for making signal measurements. The test points consist of pins with hooked ends' mounted on the circuit board. These points are clearly labeled on the board. Signal measurements can also be made at anchor terminals (AT's) on the circuit board and on connectors and panels. The AT's are identified in the illustrations and schematics in Section 6. AT's on the circuit board are clearly marked and are not prefixed by letters.

5.8 CALIBRATION.

If the instrument does not meet the minimum performance standards specified in paragraph 5.3, calibrate the instrument as follows:

NOTE

Allow two hours warm up before calibrating. If a static charge on the meter cover is suspected, wet the cover with an anti-static solution, Weston Statnul* or equivalent.

- a. Remove the dust covers according to paragraph 5.5.
- b. Set the 1807 controls to the following positions:

DIRECT-INTERPOLATE	DIRECT
INTERPOLATION OFFSET	1.0
FILTER.	IN
POLARITY	+
RANGE (ring dial)	nA-mA
RANGE (knob dial)	15 nA

c. Turn on the instrument according to Section 3 and adjust the meter-zero using the front-panel ZERO adjustment.

d. Connect the Digital Voltmeter to the RECORDER jack on the rear panel and adjust R132 (see Figure 5-2) for a DVM reading of $0 \pm 300 \mu V$, noting that the 1807 meter reads zero (adjust if necessary).

e. Set the 1807 RANGE ring dial-control to μV -kV.

f. Connect a GR Type 1822 Digital Voltmeter Calibrator to the 1807 INPUT terminals and apply a 1.0 V signal to the 1807.

g. Adjust R140 for exactly a 1.0-V reading on the 1807 meter.

h. Set the INTERPOLATION control to INTERPOLATION and adjust R102 for a 1807 meter reading of $0 \pm .005$.

*Registered trademark of Weston Instruments, Inc.

i. Set the 1807 RANGE knob dial-control to 15 V and apply 10 V to the 1807; adjust R110 for a $0 \pm .005$ reading on the 5100.

5.9 TROUBLE ANALYSIS.

5.9.1 General.

Table 5-1 lists the equipment recommended for trouble analysis. Table 5-5 lists most of the symptoms of malfunctions that can occur in the instrument, and the possible causes and/or the circuit(s) to be checked to isolate the fault. Table 5-6 contains the circuit test and test data for the power input circuit, 80-Hz oscillator, and power supplies. The schematic diagrams (Section 6) show waveforms and dc voltages at significant points in the circuits, for various operation conditions, as noted on the schematic.

Obvious checks that should be performed before trouble analysis are not listed in Table 5-5. These include power and power connections, fuses, lamps, etc. The instrument should also be inspected for broken and short-circuited wiring and damaged or faulty parts.

Use the panel controls wherever possible, to determine which part of a circuit failed. For example, it may be possible to isolate a failure to a portion of the range-setting resistors or interpolation-offset voltage-divider network by making measurements at various ranges and observing the results at each of the ranges.

5.10 REPLACEMENT OF CONTROLS.

5.10.1 RANGE and INTERPOLATION CONTROLS.

Removal. Perform the following steps to remove the controls.

- a. Set the ring dial-control full ccw and the knob dial-control full ccw.
- b. Hold the instrument securely and pull the control knob off with the fingers.

CAUTION

Do not use a screwdriver or other instrument to pry off the knob if it is tight, since this might mar or crack the dial. Do not lose the retention spring in the knob when the knob is removed.

- c. Remove the setscrew from the bushing; use a hex-socket key wrench.
- d. Remove the bushing and vernier dial.

NOTE

If the knob and dial are combined when the knob is removed, turn a machine tap a turn or two into the bushing on the dial for sufficient grip for easy separation of the knob.

- e. From the ring dial bushing, remove the two setscrews; remove the bushing and dial.

5-6 SERVICE



Table 5-5
FAULT INDICATIONS AND PROBABLE CAUSE

Fault Indication	Probable Cause	Notes
No reading in any mode of operation or the instrument reads off scale when the input is short circuited.	80-Hz oscillator, T502, power supplies and associated components (CR103 & CR105), photochopper, ac amplifier, demodulator, and/or dc amplifier.	Check the 80-Hz oscillator and power supplies. If they are operating properly, the malfunction may be in the feedback loop. Set the instrument in the open-loop condition by short circuiting AT107 to ground. Set the instrument to the 1.5-V range and apply approximately 1 V to the input. Check AT109 for a square-wave. If the square wave is not present, the malfunction is in the photoconductor circuitry or the neon bulbs. If the signal is present, check the amplifiers and demodulator in sequence. Voltages and waveforms are given on the schematic.
Instrument reads correctly in DIRECT mode but not correctly in INTERPOLATION OFFSET mode.	Calibrated floating power supply, particularly CR107; INTERPOLATION control circuitry, and/or range-setting resistors.	Check the calibrated floating power supply, INTERPOLATION-OFFSET control resistor-divider network (R301-R307), and range-setting resistors (R203-R207, R209, and R226).
Instrument is very noisy.	Q101 and/or ac amplifier.	Replace Q101. If the fault is not corrected, set the instrument in the open-loop mode of operation by short circuiting AT107 to ground and check the gain of the ac amplifier on its various ranges (gain increases at the lower ranges). Check that the light-conduction pipes have clean ends and that the neon bulbs (V102 and V103) are positioned directly in line with the pipes.
The meter zero is off on all ranges, after calibration	Dc amplifier.	
Meter reads properly but there is no recorder output or recorder output cannot be adjusted properly.	Recorder output circuit.	



5.11 LAMP-REPLACEMENT.

To replace a burnt-out pilot lamp, slide the metal clip off the back of the lamp holder and remove the lamp. Insert a new lamp (Chicago Miniature Lamp Works, No. 327) and replace the clip.

5.12 PHOTOCOPPER REPLACEMENT.

The photoconductors, light-conduction pipes, and neon bulbs are under the metal cover at the rear of the instrument (see Figure 5-2). Should it be necessary to gain access to these components, swing the board down according to the instructions in paragraph 5.5. Remove the screws on the metal cover to gain access to the components; the photoconductors are mounted at the ends of the light-conduction pipe.

If a photoconductor must be replaced, order the new part, specifying the part number and the instrument type (1807). The GR replacement photoconductor has Teflon tape wrapped around the case to prevent direct contact with the pipes.

To remove a photoconductor, unsolder the leads according to instructions in paragraph 5.6. and remove the photoconductor from the pipe. The pipe can be removed from its clip holder. (See Figure 6-2.) Insulation is provided with the replacement part, to cover the three photoconductor leads. When remounting the photoconductor, make sure the pipe only touches the Teflon-covered surface of the photoconductor.

When replacing the pipe in its holder (or when replacing a neon bulb) make sure that the neon bulb (V102 and V103) is positioned so that the filament is at the center of the pipe.

5.13 FRONT-PANEL FINISH.

If the front panel is marred or scratched, retouch, if desired, with a light gray color, conforming with Federal Standard 595 (gray, 26492).

Parts Lists and Diagrams—Section 6

6.1 GENERAL 6-1

6.1 GENERAL.

This section contains the replaceable-parts lists, schematics, and etched-board layout. The Federal manufacturer's code numbers in the parts list are identified

in the "Federal Manufacturers Code" listing. Figure 6-1 shows a front view of the Type 1807, identifying parts. Figure 5-2 shows an interior view, identifying parts.

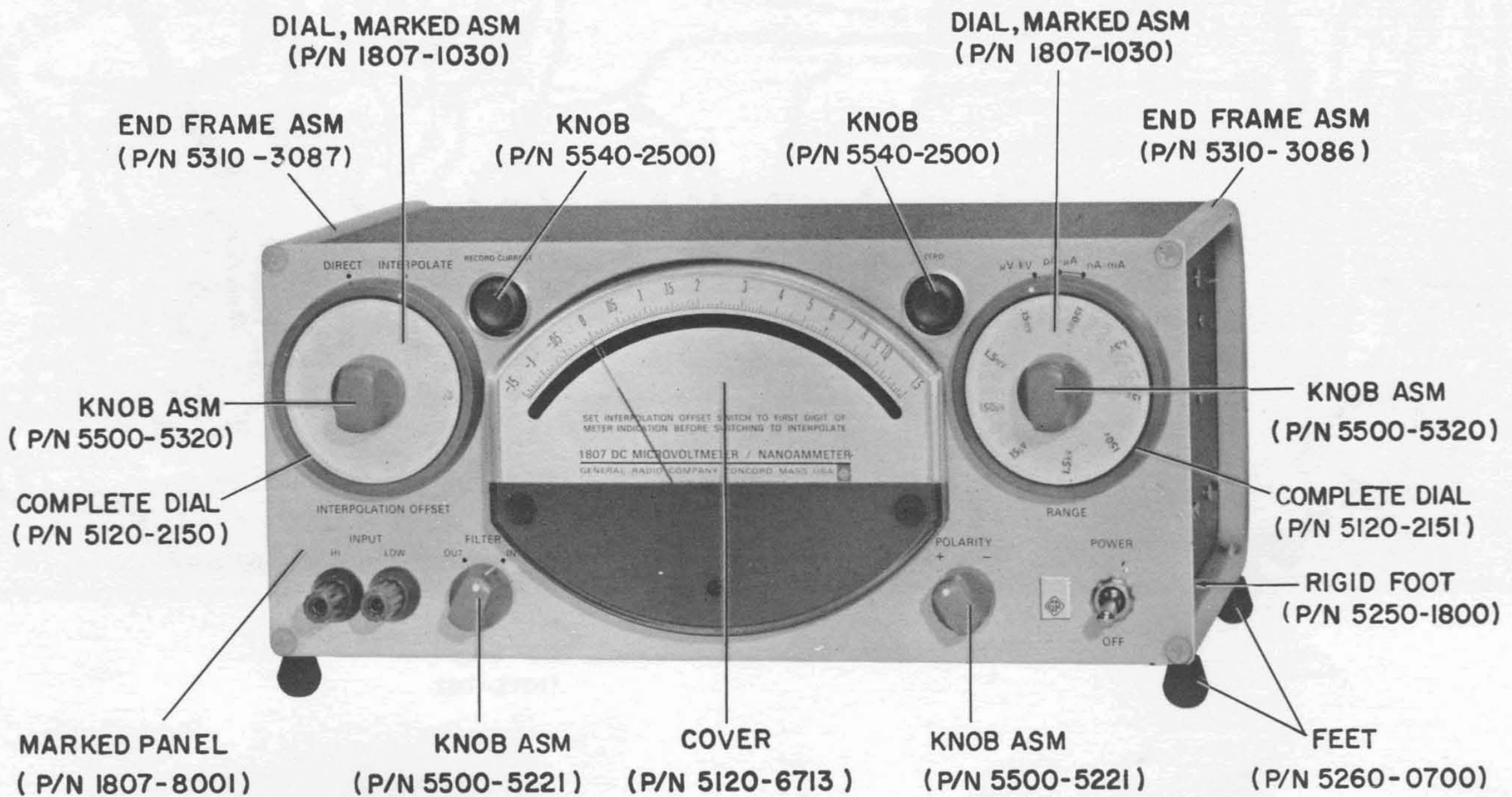
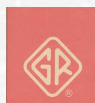

Figure 6-1. Front view of the 1807, identifying parts.



MECHANICAL PARTS LIST

<i>Description</i>	<i>GR Part No.</i>	<i>Fed. Mfg. Code</i>	<i>Mfg. Part No.</i>	<i>Fed. Stock No.</i>
Dial, Marked Asm., INTERPOLATION OFFSET	1807-1030	24655	1807-1030	
Dial, Marked Asm., RANGE	1807-1040	24655	1807-1040	
Light-tube Shield Asm	1807-1080	24655	1807-1080	
Light-tube Mounting Plate Asm.	1807-1100	24655	1807-1100	
Etched Circuit Asm.	1807-2701	24655	1807-2701	
Pivot Block (circuit board)	1807-6000	24655	1807-6000	
Pivot Block (circuit board)	1807-6010	24655	1807-6010	
Light Pipe	1807-7010	24655	1807-7010	
Panel, Marked	1807-8001	24655	1807-8001	
Power Cord	4200-9622	24655	4200-9622	6150-968-0081
Dust Cover	4429-2020	24655	4429-2020	
Dial, Complete (outer dial - INTERPOLATION)	5120-2150	24655	5120-2150	
Dial, Complete (outer dial - RANGE)	5120-2151	24655	5120-2151	
End Frame Asm. (bench model)	5310-3086	24655	5310-3086	
End Frame Asm. (bench model)	5310-3087	24655	5310-3087	
Knob Asm., POLARITY	5500-5221	24655	5500-5221	
Knob Asm., FILTER	5500-5221	24655	5500-5221	
Knob Asm., INTERPOLATION	5500-5320	24655	5500-5320	
Knob Asm., RANGE	5500-5320	24655	5500-5320	
Knob, RECORD CURRENT	5540-2500	24655	5540-2500	
Knob, ZERO	5540-2500	24655	5540-2500	
Lamp Holder, Painted	5600-1021	24655	5600-1021	
Mounting Device, Fuse	5650-0200	24655	5650-0200	
Meter Cover	5720-6713	40931	ME-6-701	
Adjustable Foot	5250-1800	24655	5250-1800	
Foot	5260-0700	24655	5260-0700	



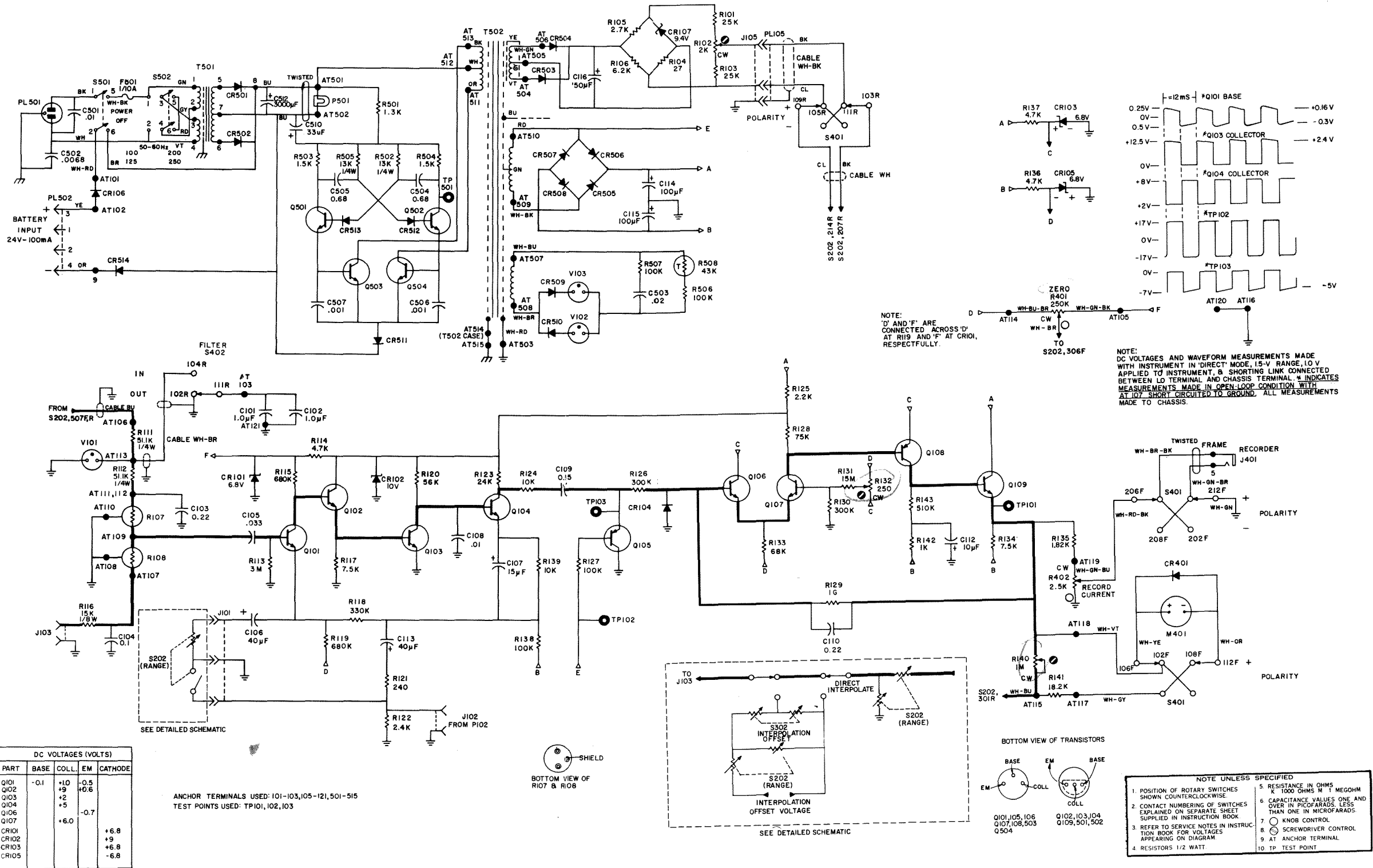

Figure 6-3. Schematic of the 1807.



ELECTRICAL PARTS LIST

Ref. No.	Description	GR Part No.	Fed. Mfg. Code	Mfg. Part No.	Fed. Stock No.
CAPACITORS					
C101	Plastic, 1.0 μ F \pm 10% 100 V	4864-5109	84411	863UW, 1.0 μ F \pm 10%	
C102	Plastic, 1.0 μ F \pm 10% 100 V	4864-5109	84411	863UW, 1.0 μ F \pm 10%	
C103	Plastic, 0.22 μ F \pm 10% 100 V	4864-4229	84411	863UW, 0.22 μ F \pm 10%	
C104	Plastic, 0.10 μ F \pm 10% 50 V	4863-4101	84411	820UB, 0.10 μ F \pm 10%	
C105	Plastic, .033 μ F \pm 10% 50 V	4863-3331	84411	820UB, .033 μ F \pm 10%	
C106	Electrolytic, 40 μ F +100-10% 6 V	4450-3600	37942	20-4070754	5910-952-0467
C107	Electrolytic, 15 μ F +100-10% 15 V	4450-3700	37942	TT, 15 μ F +100-10%	
C108	Ceramic, .01 μ F +80-20% 500 V	4406-3109	72982	811, 0.01 μ F +80-20%	5910-977-7579
C109	Plastic, 0.15 μ F \pm 10% 100 V	4860-7895	84411	663UW, 0.15 μ F \pm 10%	
C110	Plastic, 0.22 μ F \pm 5% 100 V	4860-7974	84411	663UW, 0.22 μ F \pm 5%	
C112	Electrolytic, 10 μ F \pm 100-10% 25 V	4450-3800	56289	30D106G025BB4M1	5910-952-8658
C113	Electrolytic, 40 μ F +100-10% 6 V	4450-3600	37942	20-4070754	5910-952-0467
C114	Electrolytic, 100 μ F +100-10% 25 V	4450-2300	76149	20-40595	5910-799-9284
C115	Electrolytic, 100 μ F +100-10% 25 V	4450-2300	76149	20-40595	5910-799-9284
C116	Electrolytic, 150 μ F +150-10% 50 V	4450-6050	37942	TT, 150 μ F +150-10%	5910-799-9284
C401	Plastic, .0022 μ F \pm 10% 600 V	4863-2228	56289	194P, 0.0022 μ F \pm 10%	
C501	Ceramic, .01 μ F +80-20% 500 V	4406-3109	72982	811, 0.01 μ F +80-20%	5910-977-7579
C502	Ceramic, .0068 μ F +80-20% 500 V	4406-2689	72982	811, 0.0068 μ F +80-20%	
C503	Ceramic, .02 μ F +80-20% 500 V	4402-3200	01121	35-203W, 0.02 μ F +80-20%	5910-952-8659
C504	Plastic, 0.68 μ F \pm 5% 100 V	4860-8011	84411	663UW, 0.68 μ F \pm 5%	
C505	Plastic, 0.68 μ F \pm 5% 100 V	4860-8011	84411		
C506	Ceramic, .001 μ F +80-20% 500 V	4404-2109	72982	831, 0.001 μ F +80-20%	5910-983-9994
C507	Ceramic, .001 μ F +80-20% 500 V	4404-2109	72982	831, 0.001 μ F +80-20%	5910-983-9994
C510	Electrolytic, 33 μ F \pm 20% 20V	4450-5613	80183	150D336X0020R2	
C512A	1500 μ F				
C512B	Electrolytic, 750 μ F +100-10% 25 V	4450-0700	90201	203828S10C10X2	5910-976-9415
C512C	750 μ F				
DIODES					
CR101	Type 1N957B	6083-1009	07910	1N957B	
CR102	Type 1N758A	6083-1012	07910	1N758A	
CR103	Type 1N957B	6083-1009	07910	1N957B	
CR104	Type 1N4442	6082-1009	24446	1N4442	5961-929-9967
CR105	Type 1N957B	6083-1009	07910	1N957B	
CR106	Type 1N645	6082-1016	24446	1N645	5961-944-8222
CR107	Type 1N2166A	6083-1011	07595	1N2166A	
CR401	Type 1N645	6082-1016	24446	1N645	5961-944-8222
CR501	Type 1N645	6082-1016	24446	1N645	5961-944-8222
CR502	Type 1N645	6082-1016	24446	1N645	5961-944-8222
CR503	Type 1N645	6082-1016	24446	1N645	5961-944-8222
CR504	Type 1N645	6082-1016	24446	1N645	5961-944-8222
CR505	Type 1N645	6082-1016	24446	1N645	5961-944-8222
CR506	Type 1N645	6082-1016	24446	1N645	5961-944-8222
CR507	Type 1N645	6082-1016	24446	1N645	5961-944-8222
CR508	Type 1N645	6082-1016	24446	1N645	5961-944-8222
CR509	Type 1N459A	6082-1011	07910	1N459A	5961-815-8451
CR510	Type 1N459A	6082-1011	07910	1N459A	5961-815-8451
CR511	Type 1N645	6082-1016	24446	1N645	5961-944-8222
CR512	Type 1N645	6082-1016	24446	1N645	5961-944-8222
CR513	Type 1N645	6082-1016	24446	1N645	5961-944-8222
CR514	Type 1N645	6082-1016	24446	1N645	5961-944-8222
RESISTORS					
R101	Wire wound, 25 k Ω \pm 0.07% 1/2 W	6982-5002	24655	6982-5002	
R102	Potentiometer, 2 k Ω \pm 5%	6058-2205	75042	CT-100, 2 k Ω \pm 5%	
R103	Wire wound, 25 k Ω \pm 0.07% 1/2 W	6982-5002	24655	6982-5002	
R104	Composition, 27 Ω \pm 5% 1/2 W	6100-0275	01121	RC20GF270J	5905-279-1879
R105	Composition, 2.7 k Ω \pm 5% 1/2 W	6100-2275	01121	RC20GF272J	5905-279-1880
R106	Composition, 6.2 k Ω \pm 5% 1/2 W	6100-2625	01121	RC20GF622J	5905-279-2673
R107	Photoconductor	6740-2032	12040	NSL-384SC	
R108	Photoconductor	6740-2032	12040	NSL-384SC	
R109	Film, 10.2 k Ω \pm 1% 1/4 W	6350-2102	75042	CEB, 10.2 k Ω \pm 1%	
R110	Potentiometer, 500 Ω \pm 20%	6040-0300	01121	FWC, 500 Ω \pm 20%	5905-072-7795
R111	Film, 51.1K \pm 1% 1/4 W	6350-2511	75042	CEB, 51.5 k Ω 1%	5905-733-9518
R112	Film, 51.1K \pm 1% 1/4 W	6350-2511	75042	CEB, 51.5 k Ω 1%	5905-733-9518
R113	Composition, 3 M Ω \pm 5% 1/2 W	6100-5305	01121	RC20GF305J	5905-279-2664
R114	Composition, 4.7 k Ω \pm 5% 1/2 W	6100-2475	01121	RC20GF472J	5905-279-3504
R115	Composition, 680 k Ω \pm 5% 1/2 W	6100-4685	01121	RC20GF684J	5905-171-2000
R116	Film, 15 k Ω \pm 1% 1/8 W	6250-2150	75042	CEA, 15 k Ω 1%	5905-581-7626
R117	Composition, 7.5 k Ω \pm 5% 1/2 W	6100-2755	01121	RC20GF752J	5905-249-4195
R118	Composition, 330 k Ω \pm 5% 1/2 W	6100-4335	01121	RC20GF334J	5905-279-2519
R119	Composition, 680 k Ω \pm 5% 1/2 W	6100-4685	01121	RC20GF684J	5905-171-2000



ELECTRICAL PARTS LIST (cont)

Ref. No.	Description	GR Part No.	Fed. Mfg. Code	Mfg. Part No.	Fed. Stock No.
R120	Composition, 56 kΩ ±5% 1/2 W	6100-3565	01121	RC20GF563J	5905-171-1986
R121	Composition, 240 Ω ±5% 1/2 W	6100-1245	01121	RC20GF241J	5905-279-2593
R122	Composition, 2.4 kΩ ±5% 1/2 W	6100-2245	01121	RC20GF242J	5905-279-1877
R123	Composition, 24 kΩ ±5% 1/2 W	6100-3245	01121	RC20GF243J	5905-279-1878
R124	Composition, 10 kΩ ±5% 1/2 W	6100-3105	01121	RC20GF103J	5905-185-8510
R125	Composition, 2.2 kΩ ±5% 1/2 W	6100-2225	01121	RC20GF222J	5905-279-1876
R126	Composition, 300 kΩ ±5% 1/2 W	6100-4305	01121	RC20GF304J	5905-185-6859
R127	Composition, 100 kΩ ±5% 1/2 W	6100-4105	01121	RC20GF104J	5905-195-6761
R128	Composition, 75 kΩ ±5% 1/2 W	6100-3755	01121	RC20GF753J	5905-279-3495
R129	Composition, 100 MΩ ±5% 1/2 W	6100-7105	01121	EB, 100 MΩ ±5%	
R130	Composition, 300 kΩ ±5% 1/2 W	6100-4305	01121	RC20GF304J	5905-185-6859
R131	Composition, 15 MΩ ±5% 1/2 W	6100-6155	01121	EB, 15 MΩ ±5%	
R132	Pot., 250 kΩ ±20%	6040-1100	01121	FWC, 250 kΩ ±20%	
R133	Composition, 68 kΩ ±5% 1/2 W	6100-3685	01121	RC20GF683J	5905-249-3661
R134	Composition, 7.5 kΩ ±5% 1/2 W	6100-2755	01121	RC20GF752J	5905-249-4195
R135	Film, 1.82 kΩ ±1% 1/2 W	6450-1182	75042	CEC-TO, 1.82 kΩ ±1%	5905-518-5989
R136	Composition, 4.7 kΩ ±5% 1/2 W	6100-2475	01121	RC20GF472J	5905-279-3504
R137	Composition, 4.7 kΩ ±5% 1/2 W	6100-2475	01121	RC20GF472J	5905-279-3504
R138	Composition, 100 kΩ ±5% 1/2 W	6100-4105	01121	RC20GF104J	5905-195-6761
R139	Composition, 10 kΩ ±5% 1/2 W	6100-3105	01121	RC20GF103J	5905-185-8510
R140	Pot., 1 MΩ ±20%	6040-1500	01121	FWC, 1 MΩ ±20%	
R141	Film, 18.2 kΩ ±1% 1/2 W	6450-2182	75042	CEC-TO, 18.2 kΩ ±1%	
R142	Composition, 1 kΩ ±5% 1/2 W	6100-2105	01121	RC20GF102J	5905-195-6806
R143	Composition, 510 kΩ ±5% 1/2 W	6100-4515	01121	RC20GF514J	5905-279-2516
R201	Film, 1 MΩ ±0.1% 1/4 W	6192-4100	75042	MEB-T9, 1 MΩ ±0.1%	
R202	Wire wound, 1 kΩ ±0.07% 1/8 W	6981-4001	24655	6981-4001	
R203	Wire wound, 6.544 kΩ ±0.07% 1/8 W	6981-4002	24655	6981-4002	
R204	Wire wound, 597.2 Ω ±0.07% 1/8 W	6981-3000	24655	6981-3000	
R205	Wire wound, 450 Ω ±0.07% 1/8 W	6981-3001	24655	6981-3001	
R206	Wire wound, 44.96 Ω ±0.07% 1/8 W	6981-2000	24655	6981-2000	
R207	Wire wound, 5.12 Ω ±0.25% 1/8 W	6981-1000	24655	6981-1000	
R209	Wire wound, 75.27 Ω ±0.07% 1/8 W	6981-2001	24655	6981-2001	
R210	Wire wound, 9.65 Ω ±0.25% 1/8 W	6981-1003	24655	6981-1003	
R212	Wire wound, 1 Ω ±1% 1/8 W	6981-1002	24655	6981-1002	
R213	Wire wound, 7.92 kΩ ±0.25% 1/8 W	6981-4004	24655	6981-4004	
R214	Wire wound, 792 Ω ±0.25% 1/8 W	6981-3002	24655	6981-3002	
R215	Wire wound, 79.2 Ω ±0.25% 1/8 W	6981-2002	24655	6981-2002	
R216	Wire wound, 90 Ω ±0.25% 1/8 W	6981-2003	24655	6981-2003	
R217	Wire wound, 9 Ω ±0.5% 1/8 W	6981-1001	24655	6981-1001	
R218	Composition, 24 kΩ ±5% 1/2 W	6100-3245	01121	RC20GF243J	5905-279-1878
R219	Composition, 2.4 kΩ ±5% 1/2 W	6100-2245	01121	RC20GF242J	5905-279-1877
R220	Composition, 240 Ω ±5% 1/2 W	6100-1245	01121	RC20GF241J	5905-279-2593
R221	Composition, 820 kΩ ±5% 1/2 W	6100-4825	01121	RC20GF824J	5905-221-5848
R222	Film, 3.5 MΩ ±5% 1 W	6551-4350	80183	421E, 3.5 MΩ ±5%	
R223	Film, 3.5 MΩ ±5% 1 W	6551-4350	80183	421E, 3.5 MΩ ±5%	
R224	Film, 3.5 MΩ ±5% 1W	6551-4350	80183	421E, 3.5 MΩ ±5%	
R225	Composition, 7.5 MΩ ±5% 1/2 W	6100-5755	01121	RC20GF755J	5905-279-2508
R226*	Composition, 510 kΩ ±5% 1/2 W	6100-1515	01121	RC20GF511J	5905-279-3511
R301	Wire wound, 12 kΩ ±0.07% 1/2 W	6982-5001	24655	6982-5001	
R302	Wire wound, 12 kΩ ±0.07% 1/2 W	6982-5001	24655	6982-5001	
R303	Wire wound, 12 kΩ ±0.07% 1/2 W	6982-5001	24655	6982-5001	
R304	Wire wound, 3 kΩ ±0.07% 1/8 W	6981-4006	24655	6981-4006	
R305	Wire wound, 6 kΩ ±0.07% 1/8 W	6981-4007	24655	6981-4007	
R306	Wire wound, 3 kΩ ±0.07% 1/8 W	6981-4006	24655	6981-4006	
R307	Wire wound, 6 kΩ ±0.07% 1/8 W	6981-4007	24655	6981-4007	
R401	Pot., comp., 250 kΩ ±10%	6040-1790	01121	JV, 250 kΩ ±10%	
R402	Potentiometer, 2.5 kΩ ±10%	1807-0400	24655	1807-0400	
R501	Composition, 1.3 kΩ ±5% 1/2 W	6100-2135	01121	RC20GF132J	5905-279-1870
R502	Film, 13 kΩ ±1% 1/4 W	6350-2130	75042	CEB-TO, 13 kΩ ±1%	
R503	Composition, 1.5 kΩ ±5% 1/2 W	6100-2155	01121	RC20GF152J	5905-841-7461
R504	Composition, 1.5 kΩ ±5% 1/2 W	6100-2155	01121	RC20GF152J	5905-841-7461
R505	Film, 13 kΩ ±1% 1/4 W	6350-2130	75042	CEB-TO, 13 kΩ ±1%	
R506	Composition, 100 kΩ ±5% 1/2 W	6100-4105	01121	RC20GF104J	5905-195-6761
R507	Composition, 100 kΩ ±5% 1/2 W	6100-4105	01121	RC20GF104J	5905-195-6761
R508	Thermistor, 43 kΩ ±10%	6740-2025	02606	RA4421	
TUBES					
V101	Neon lamp, Type NE-2	8390-0200	24446	NE-2	6240-179-1811
V102	Neon lamp, Type A1C	8390-0320	24455	A1C	
V103	Neon lamp, Type A1C	8390-0320	24455	A1C	

* Value May Be Selected by General Radio



ELECTRICAL PARTS LIST (cont)

<i>Ref. No.</i>	<i>Description</i>	<i>GR Part No.</i>	<i>Fed. Mfg. Code</i>	<i>Mfg Part No.</i>	<i>Fed Stock No.</i>
TRANSISTORS					
Q101	Type 2N4384	8210-1131	93916	2N4384	
Q102	Type 2N3390	8210-1077	24454	2N3390	
Q103	Type 2N3416	8210-1047	24446	2N3414	5961-989-2749
Q104	Type 2N3390	8210-1077	24454	2N3390	
Q105	Type 2N1920	8210-1061	56232	2N1920	
Q106	Type 2N4384	8210-1131	93916	2N4384	
Q107	Type 2N4384	8210-1131	93916	2N4384	
Q108	Type 2N4250	8210-1135	93916	2N4250	
Q109	Type 2N3416	8210-1047	24446	2N3414	5961-989-2749
Q501	Type 2N3416	8210-1047	24446	2N3414	5961-989-2749
Q502	Type 2N3416	8210-1047	24446	2N3414	5961-989-2749
Q503	Type 2N698	8210-1058	93916	2N698	5960-985-3709
Q504	Type 2N698	8210-1058	93916	2N698	5960-985-3709
FUSE					
F501	Slo-blow, 0.1 Amp.	5330-0400	71400	MDL, .1 Amp.	5920-356-2185
METER					
M401	157 μ A	5730-1399	40931	Meds-1399	
SWITCHES					
S201	Rotary, wafer	7890-4620	24655	7890-4620	
S202	Rotary, wafer	7890-4620	24655	7890-4620	
S301	Rotary, wafer	7890-4630	24655	7890-4630	
S302	Rotary, wafer	7890-4630	24655	7890-4630	
S401	Rotary, wafer	7890-4640	24655	7890-4640	
S402	Rotary, wafer	7890-4650	24655	7890-4650	
S501	Toggle, POWER OFF	7910-1300	04009	83053-SA	5930-909-3510
S502	Line-Voltage Selector	7910-0831	42190	4603	
TRANSFORMERS					
T501		0745-4430	24655	0745-4430	
T502		0745-4450	24655	0745-4450	
PLUGS					
PL501	Connector, power	4240-0600	24655	4240-0600	5935-816-0254
PL502	Connector, multiple	4220-4400	71785	P-304-AB	
JACKS					
J401	Phone	4260-1032	82389	L111	
J402	Phone	4060-0408	24655	4060-0408	
J403	Phone	4060-0418	24655	4060-0418	
J404	Binding post	4060-0408	24655	4060-0408	
J405	Binding post	4060-0418	24655	4060-0418	
J406	Binding post	0938-3016	24655	0938-3016	
PILOT LIGHT					
P501	28V	5600-0307	71744	#327	



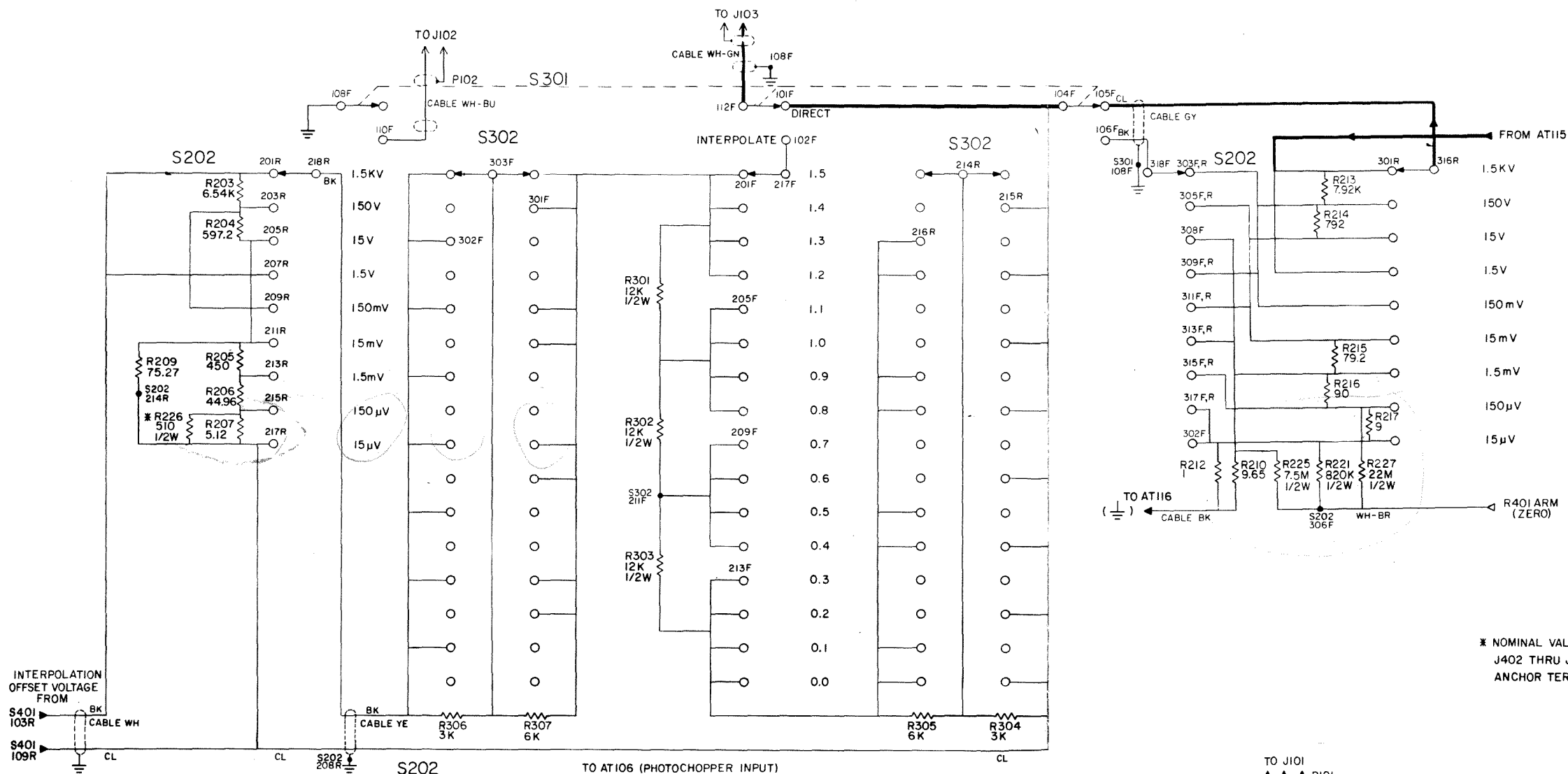

S202 (RANGE)
S201 (μV-mA)
S302 (INTERPOLATION OFFSET)
S301 (DIRECT-INTERPOLATE)

* NOMINAL VALUE FACTORY ADJUSTED.
J402 THRU J406 ARE BINDING POSTS.
ANCHOR TERMINALS USED: 104, 116, 401-403

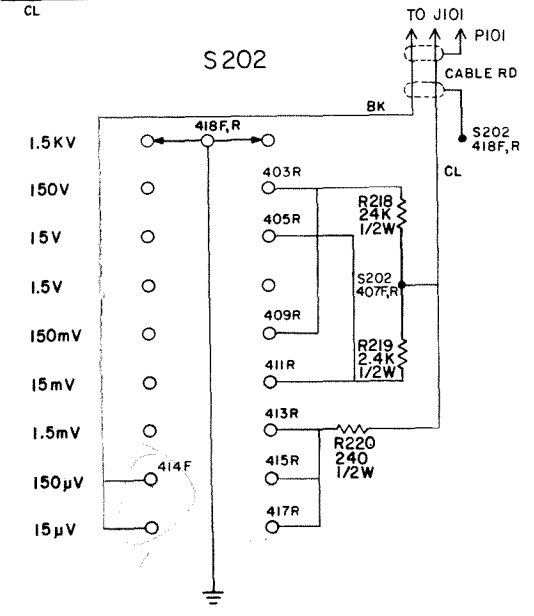
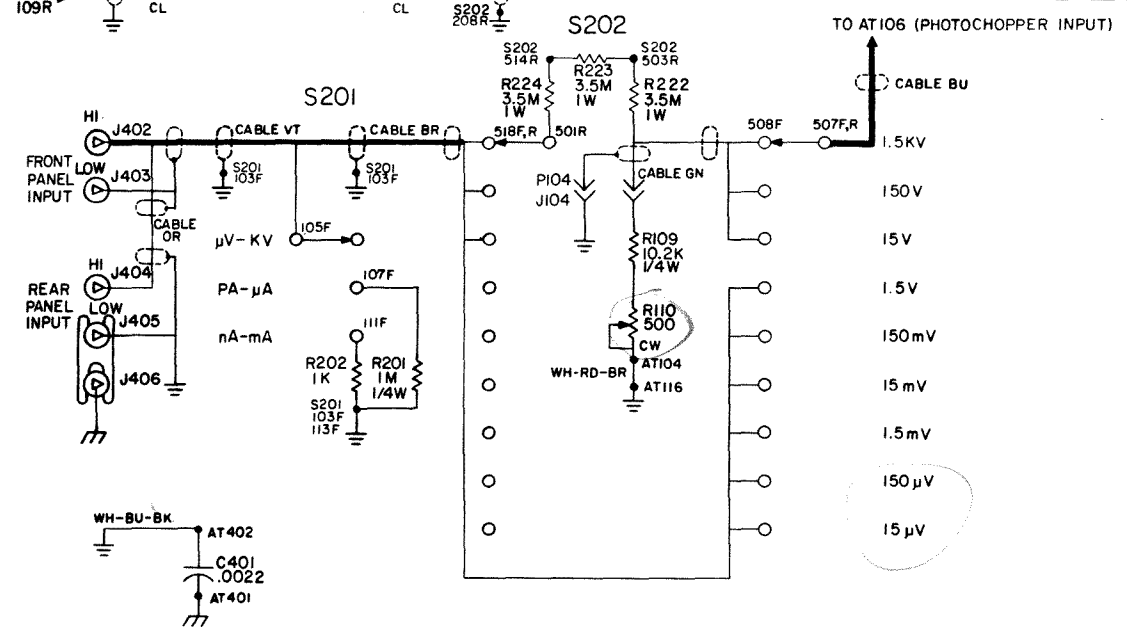

GENERAL RADIO

300 BAKER AVENUE, CONCORD, MASSACHUSETTS 01742

EASTERN REGIONAL CENTER

Connecticut, Delaware, New Jersey, New York
Eastern Pennsylvania, Rhode Island

380 Midland Avenue, Saddle Brook, New Jersey 07662
Telephone: (NJ) 201 791-8990 (NY) 212 964-2722

New England Area

Maine, Massachusetts, New Hampshire, Vermont
Bolton, Massachusetts 01740
Telephone: 617 646-0550

CENTRAL REGIONAL CENTER

Illinois, Indiana, Iowa, Kansas, Kentucky, Michigan, Minnesota
Missouri, Nebraska, North Dakota, Ohio, South Dakota,
Western Pennsylvania, Wisconsin

9440 West Foster Avenue, Chicago, Illinois 60656
Telephone: 312 992-0800

SOUTHERN REGIONAL CENTER

Alabama, Arkansas, Florida, Georgia, Louisiana, Maryland, Mississippi
North Carolina, Oklahoma, South Carolina, Tennessee, Texas,
Virginia, West Virginia, (Wash. D.C.)

P. O. Box 2205, 11420 Rockville Pike,
Rockville, Maryland 20852
Telephone: 301 881-5333

WESTERN REGIONAL CENTER

Arizona, California, Colorado, Hawaii, Idaho, Montana,
Nevada, New Mexico, Oregon, Utah, Washington, Wyoming
17361 Armstrong Avenue,

Irvine Industrial Complex, Santa Ana, California 92705
Telephone: 714 540-9830

Alaska 907 279-5741

CANADA

General Radio Canada Limited

307 Evans Avenue, Toronto 530 Ontario
Telephone: 416 252-3395
Montreal 514 737-2126
Ottawa 613 233-4237

EUROPE, AFRICA, and NEAR EAST

General Radio Company (Overseas)

P. O. Box 124, CH-8034, Zurich, Switzerland
Telephone: (01) 55 24 20

ASIA, PACIFIC, and LATIN AMERICA

General Radio International Division

Concord, Mass 01742
Cable: GENRADCO CONCORD (Mass)

GR COMPANIES

Grason-Stadler

56 Winthrop Street, Concord, Massachusetts 01742
Telephone: 617 369-3787

Time/Data

490 San Antonio Road, Palo Alto, California 94306
Telephone: 415 327-8322

Printed in USA

