

**OPERATING INSTRUCTIONS**



# **TYPE 1652-A**

---

**RESISTANCE LIMIT BRIDGE**

**GENERAL RADIO COMPANY**



File Courtesy of GRWiki.org

# OPERATING INSTRUCTIONS

## TYPE 1652-A

# RESISTANCE LIMIT BRIDGE

Form 1652-0110-G  
July, 1964

Copyright 1964 by General Radio Company  
Concord, Massachusetts, USA

G E N E R A L R A D I O C O M P A N Y  
W E S T C O N C O R D , M A S S A C H U S E T T S , U S A





## SPECIFICATIONS

**Resistance Range:** As a limit bridge, 1 ohm to 1,111,111 ohms with internal standard; for null measurement, 1 ohm to 1,111,111 ohms with internal standard; 1 ohm to 2 megohms with external standard.  
**Limit Range:** Meter reads from  $-20\%$  to  $+20\%$ , with the standard EIA (RETMA) tolerance range of  $\pm 5\%$  and  $\pm 10\%$  clearly indicated by gold and silver coloring, respectively.

**Accuracy:** As a limit bridge,  $\pm 0.5\%$  or better; for matching,  $\pm 0.2\%$ ; for null measurement, with internal standard,  $\pm 0.25\%$  above 10 ohms and  $\pm 0.4\%$  between 1 ohm and 10 ohms; with an external standard, from 1 ohm to 2 megohms  $\pm (0.2\% + \text{accuracy of standard})$ .

**Voltage Applied to Unknown:** One volt when the meter indication is zero; 0.9 volt at  $-20\%$ ; 1.1 volts at  $+20\%$ .

**Power Requirements:** 105 to 125 (or 210 to 250) volts, 60 cps. The power input is approximately 30 watts.

**Accessories Supplied:** TYPE CAP-22 Power Cord, spare fuses.

**Cabinet:** Rack-bench.

**Dimensions:** Bench model — width 19, height  $8\frac{3}{4}$ , depth  $12\frac{1}{4}$  inches (485 by 225 by 315 mm), over-all; rack model — panel 19 by  $8\frac{3}{4}$  inches (485 by 225 mm), depth behind panel 11 inches (280 mm).

**Net Weight:** 29 pounds (13.5 kg).

**Shipping Weight:** 43 pounds (19.6 kg).

**CAUTION**  
REMOVE PROTECTIVE WIRE SHUNT FROM  
TERMINALS OF LARGE METER BEFORE USING.

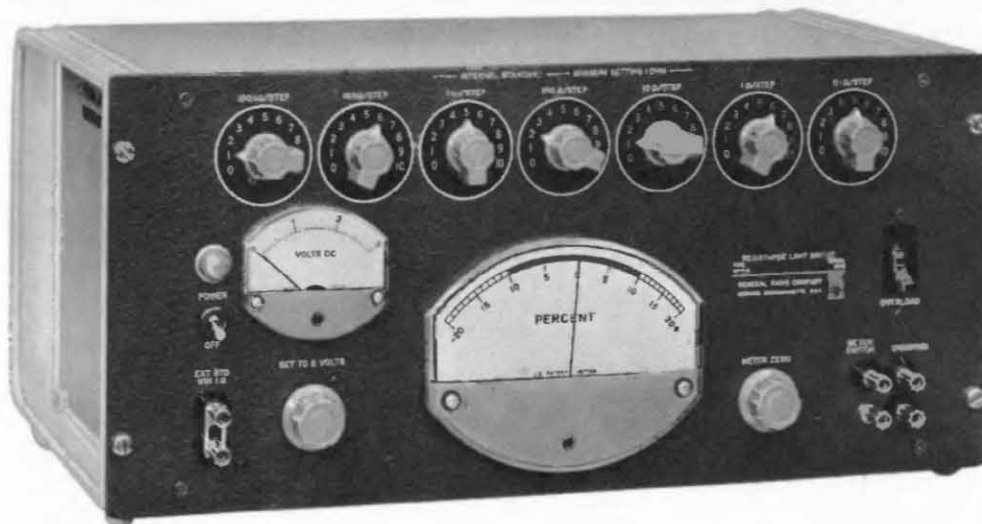

Figure 1-1. The Type 1652-A Resistance Limit Bridge.

SECTION 1

INTRODUCTION

**CAUTION**  
**REMOVE PROTECTIVE WIRE SHUNT FROM**  
**TERMINALS OF LARGE METER BEFORE USING.**

**1.1 PURPOSE.**

The Type 1652-A Resistance Limit Bridge is intended primarily for production testing of resistors at dc. It can be used:

- To indicate deviation from nominal value.
- To match pairs of resistors.
- To compare resistors with a standard sample.
- To measure resistance by the null method.

**1.2 DESCRIPTION.**

The resistance limit bridge uses a conventional equal-arm Wheatstone bridge circuit. The bridge circuit is supplied by a constant-voltage dc source and its output is measured by an electronic voltmeter calibrated in the percentage difference between the unknown and the standard resistors over a range of  $\pm 20\%$ .

The built-in standard resistor consists of seven Type 510 Decade Resistors and is adjustable in 0.1-ohm steps up to 1,111,111 ohms. An overload relay protects the standard resistor and the unknown resistor against burnout. It trips at about 1.2 amperes.

**1.3 CONTROLS.**

The following controls are on the panel of the Type 1652-A Resistance Limit Bridge:

**INTERNAL STANDARD ....** Seven 10-position rotary switches (0.1  $\Omega$  /STEP to 100k $\Omega$  /STEP) used to set

the internal standard resistor from values of 1 $\Omega$  to 1,111,111 $\Omega$ .

**POWER .....** 2-position toggle switch used to turn instrument on and off.

**SET TO 2 VOLTS .....** Continuous rotary control used to set dc voltage applied to bridge circuit.

**METER ZERO .....** Continuous rotary control used to set PERCENT meter to zero when input to electronic volt-meter circuit is grounded.

**OVERLOAD .....** Circuit breaker used to protect standard and unknown resistors against burnout. Trips at about 1.2 amperes.

**1.4 CONNECTORS.**

**EXT STD .....** Two 3/4 inch-spaced binding posts used to connect an external standard resistor in the bridge circuit. A shorting link connects the two binding posts together when an external standard is not used.





**METER SWITCH** ..... Two 3/4-inch-spaced binding posts connected to the input of the electronic voltmeter (lower binding post grounded). When the binding posts are shorted together, electronic voltmeter input is shorted and **METER ZERO** control can be set. May also be used to connect an external detector or to connect a selector mechanism (amplifier and relay arrangement) for automatic sorting.

**UNKNOWN** ..... Two 3/4-inch-spaced binding posts used to connect the unknown resistor in the bridge circuit.

Low-thermal-emf binding posts are used for the **EXT STD** and **UNKNOWN** connections. The critical parts of these binding posts are made of gold-plated copper, designed to minimise spurious dc signals caused by thermal disturbances. They are particularly useful in the presence of low-level signals such as those encountered when a bridge is at or near balance.

**1.5 ACCESSORIES SUPPLIED.**

1 each Type CAP-22 3-wire power cord: part number 4200-9622.

1 each fuse: 0.3 amp, slow blow, 3AG, part number 5330-0800 (if bridge is wired for 115-volt operation).

or

1 each fuse: 0.15 amp, slow blow, 3AG, part number 5330-0500 (if bridge is wired for 230-volt operation).

**1.6 ACCESSORIES AVAILABLE.**

The Type 1650-PI Test Jig provides a way to connect components quickly to a pair of terminals. It can be placed on the bench directly in front of the operator. The 0.08-ohm lead resistance has effect only when very low resistances are measured.



**Figure 1-2.**  
**The Type 1650-PI**  
**Test Jig.**



## SECTION 2

## OPERATION

## CAUTION

REMOVE PROTECTIVE WIRE SHUNT FROM  
TERMINALS OF LARGE METER BEFORE USING.

## 2.1 POWER.

## 2.1.1 GENERAL.

The total power input is approximately 30 watts. The frequency is 60 cycles and the voltage is either 105 to 125 volts or 210 to 250 volts. The power line voltage and frequency are indicated on a plate located near the power receptacle.

## 2.1.2 VOLTAGE CONVERSION.

If it is desired to change the input voltage from one range to the other:

- Change the power transformer connections as shown in Figure 2-1.
- Reverse the power-line label to indicate the power line voltage.
- Change the fuses (at the rear of the cabinet) to the proper rating (0.3 ampere for 115-volt operation, 0.15 ampere for 230-volt operation).

**Figure 2-1.**  
**Input Voltage Connections.**  
For 115-volt operation, connect to 1 and 2.  
For 230-volt operation, connect to 3 and 4.

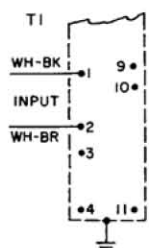

## 2.2 MOUNTING.

## 2.2.1 BENCH MOUNTING.

The resistance limit bridge is available equipped for either bench or relay-rack mounting. Subsequent conversion, however, is quite simple. For bench mounting (Type 1652-AM), aluminum end frames (part number 5310-9650, per set) are supplied to fit the ends of the cabinet. Each end frame is attached to the instrument with two panel screws and four 10-32 round-head screws with notched washers.

The end frames serve several purposes. They allow instruments to be neatly stacked and, if desired, bolted together. They also serve as supporting feet, carrying handles, and protective bumpers.

## 2.2.2 RACK MOUNTING.

For rack mounting (Type 1652-AR), special rack-mounting brackets are supplied (part number 7860-9605, per set) to attach the cabinet and the instrument to the relay rack. These brackets permit either cabinet or instrument to be withdrawn independently of the other.

To install the instrument in a relay rack:

- Attach each mounting bracket (A) to the rack with two 12-24 round-head screws (B). Use the inside holes on the brackets.
- Slide the instrument onto the brackets as far as it will go.
- Insert the two panel screws with attached washers



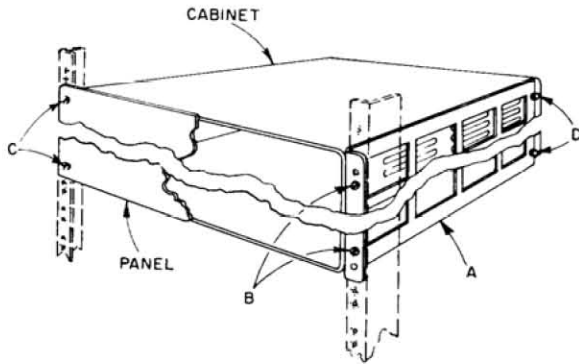

**Figure 2-2. Installation of relay-rack model, Type 1652-AR.**

(C) through the panel and the bracket and thread them into the rack.

d. Toward the rear of each bracket, put thumb screws (D) through the slots in the bracket and into the holes in the side of the cabinet.

e. On the rear of the cabinet, remove the two round-head screws that hold the cabinet to the instrument.

To remove the instrument from the rack, remove only the two panel screws with washers (C) and draw the instrument forward out of the rack.

To remove the cabinet and leave the instrument mounted in the rack, remove only the two thumb screws (D) at the rear of the brackets and pull the cabinet back off the instrument from the rear of the rack.

## 2.3 USE AS A RESISTANCE LIMIT BRIDGE.

### 2.3.1 OPERATION.

a. Turn the POWER switch on and allow a few minutes for the bridge to warm up.

b. Set the INTERNAL STANDARD to the value of the resistance to be measured and connect the resistor to the UNKNOWN binding posts.

c. Short the METER SWITCH binding posts together and turn the OVERLOAD switch on.

d. Set the SET TO 2 VOLTS control for a VOLTS DC meter reading of 2, then set the METER ZERO control for a PERCENT meter reading of 0.

e. Disconnect the short between the METER READS binding posts and read the percent error on the PERCENT meter.

### 2.3.2 ZERO DRIFT, PRODUCTION TESTING.

During operation of the bridge the METER ZERO will occasionally have to be reset. To do this, the METER SWITCH binding posts must be shorted together. For production testing, therefore, it is convenient to construct a jig that will automatically short the METER SWITCH binding posts together each time the resistor under test is removed. This can be done with a "micro-switch" that normally short-circuits the METER SWITCH binding posts, but which opens when a resistor is placed in the jig. With such a device the operator has a continuous check on the zero of the bridge. Note that the Type 1650-P1 Test Jig mentioned in paragraph 1.6 has no provision for shorting the METER SWITCH binding posts.

### 2.3.3 RESISTOR COMPARISON, USE OF EXTERNAL STANDARD.

If it is desired to compare resistors with an external standard or to an acceptable sample, remove the shorting link from the EXT STD binding posts and set the INTERNAL STANDARD to zero. Connect the external standard or the sample resistor to the EXT STD binding posts and proceed as in paragraph 2.3.1.

## 2.4 MEASUREMENTS BY THE NULL METHOD.

Proceed as in paragraph 2.3.1. Then set the standard resistor for a PERCENT meter reading of 0. To check the zero, short the METER SWITCH binding posts together. If the meter pointer does not move, read the value of the unknown from the standard resistor.

## 2.5 MEASUREMENTS LESS THAN 5 OHMS.

### 2.5.1 LEAD RESISTANCE AFFECTS MEASUREMENTS.

When measurements below 5 ohms are to be made, the resistance of ordinary leads and contacts becomes an appreciable fraction of the resistance being measured. It is therefore necessary to make all connections to the bridge with low-resistance leads. Number 12 copper wire is adequate if the total length of the leads to the unknown resistor is less than 10 feet. Even this amount of lead resistance must be compensated for in order to obtain accurate readings.

### 2.5.2 LEAD-RESISTANCE COMPENSATION.

To compensate for lead resistance, replace the shorting link on the EXT STD binding posts with an equal length of the same type of lead used on the unknown resistor. This compensation can, of course, be left on the bridge when higher values of resistance are measured.

## 2.6 MEASUREMENTS OVER 2 MEGOHMS.

### 2.6.1 GRID CURRENT AFFECTS MEASUREMENTS.

When measurements above a few megohms are to be made, the grid current drawn through the Wheatstone bridge by the electronic voltmeter will affect the normal operation of the bridge. However, it is still possible to measure resistors by the null method if the grid current is compensated for.

### 2.6.2 GRID-CURRENT COMPENSATION.

To compensate for grid current, connect the standard to the EXT STD binding posts and set the INTERNAL STANDARD to zero. Connect the resistor to be measured to the UNKNOWN terminals, turn the OVERLOAD switch OFF, and set the METER ZERO control for a PERCENT meter reading of 0. Repeat this procedure until the PERCENT meter needle does not move as the OVERLOAD switch is turned ON and OFF. The value of the standard resistance now equals that of the unknown resistor.

## SECTION 3

## SERVICE AND MAINTENANCE

## 3.1 WARRANTY.

We warrant that each new instrument sold by us is free from defects in material and workmanship, and that, properly used, it will perform in full accordance with applicable specifications for a period of two years after original shipment. Any instrument or component that is found with the two-year period not to meet these standards after examination by our factory, district office, or authorized repair agency personnel, will be repaired, or at our option, replaced without charge, except for tubes, or batteries that have given normal service.

## 3.2 SERVICE.

The two-year warranty stated above attests the quality of materials and workmanship in our products. When difficulties do occur, our service engineers will assist in any way possible. If the difficulty cannot be eliminated by use of the following service instructions, please write or phone our Service Department (see rear cover), giving full information of the trouble and of steps taken to remedy it. Be sure to mention the type and serial numbers of the instrument.

Before returning an instrument to General Radio for service, please write to our Service Department or nearest district office, requesting a Returned Material Tag. Use of this tag will ensure proper handling and identification. For instruments not covered by the warranty, a purchase order should be forwarded to avoid unnecessary delay.

## 3.3 TROUBLE SHOOTING.

## 3.3.1 EXCESSIVE SWITCH RESISTANCE.

If the decade standard switches are not used for a long period of time they may develop sufficient con-

tact resistance to affect the accuracy of settings below 5 ohms. To clean these contacts, rotate the switches over all ten positions several times. Note that all seven of the decade switches must be cleaned in this manner, since they are all in the circuit even when they are set to zero.

## 3.3.2 METER ZERO ADJUSTMENT INADEQUATE.

As tubes age it may become impossible to set zero with the panel adjustment provided. A second, internal adjustment is also provided (R14). With the METER ZERO control set to the mid-point of its range, readjust R14 to zero the meter.

## 3.3.3 PERCENT METER INACCURACIES.

The adjustable resistor R5 is provided to adjust the sensitivity of the meter. This is a factory adjustment and should not ordinarily be touched.

If readjustment is required for any reason, recalibration can be made in terms of the precision decade resistors of the bridge. To establish an accurate 20% unbalance for calibration purposes, connect a resistor (say, 10,000 ohms) to the bridge, balance the bridge, and then offset the internal standard by the required amount. This will be 83.33% of the value of the external resistor at the +20 end of the meter scale (or 125% at the -20 end of the scale). Precise calibration at any point on the meter scale can be obtained from:

$$\Delta R\% = 100 \left( \frac{R_{\text{external}}}{R_{\text{internal}}} - 1 \right)$$

## 3.3.4 VOLTAGE MEASUREMENTS.

Voltage measurements are listed in Table 3-1. Measurements were made with the METER SWITCH





terminals shorted, the UNKNOWN terminals open, and the METER ZERO control set. Ac measurements were taken with a voltmeter of 1000 ohms per volt. Dc measurements marked (\*) were taken with a Type 1806-A Electronic Voltmeter (open grid connections).

**Table 3-1.**  
**Voltage Measurements**

Pin	Tube	Voltage	
V1	1 to ground	185	ac
6 x 4 rectifier	3 to 4	6	ac
	6 to ground	185	ac
	7 to ground	170	dc
V2	1 to 3	-1.5	dc*
6SU7-GTY voltmeter- amplifier	2 to 3	102	dc*
	3 to ground	-101	dc*
	4 to 6	-1.5	dc*
	5 to 6	102	dc*
	6 to ground	-101	dc*
	7 to 8	6	ac
V3	1 to 3	-1.2	dc*
6SU7-GTY voltmeter- amplifier	2 to 3	83	dc*
	3 to ground	1.2	dc*
	4 to 6	-1.2	dc*
	5 to 6	83	dc*
	6 to ground	1.2	dc*
	7 to 8	6	ac
Voltage across C2		340	dc
Total power		30	watts

**3.4 CALIBRATION PROCEDURE.**

**3.4.1 EQUIPMENT REQUIRED.**

The following equipment is required for a complete calibration of the Type 1652-A Resistance Limit Bridge:

DC voltmeter—20,000 ohms per volt, 1% accuracy, and capable of measuring 2 volts to 380 volts.

Metered adjustable autotransformer—capable of supplying 30 watts at 105 to 125 volts (or 210 to 250 volts if the Type 1652-A is so connected) and containing a 3% ac voltmeter to monitor the output. Any metered Variac® autotransformer may be used.

Decade resistor—accurate to ±0.05% and containing 5 decades from 10Ω per step to 100 kΩ per step. The Type 1432-P Decade Resistor may be used.

Matched pair of 1-ohm resistors—two 1-ohm, 2-watt resistors matched to within ±0.1% of each other.

**3.4.2 POWER SUPPLY.**

Setup. Turn the OVERLOAD switch OFF. Connect the Type 1652-A to an adjustable autotransformer, set the autotransformer to 115 volts (230 volts if the Type 1652-A is so connected), and turn the POWER switch on.

Voltage measurements. Use a dc voltmeter of at least 20,000 ohms per volt to measure the following voltages:

Check point	Voltage
V1, pin 7 to ground	152 to 187 v dc (170 v ±10%)
Across C1 (outboard electrolytic capacitor, nearest the selenium rectifiers)	4.32 to 5.28 v dc (4.8 v ±10%)
Across C2 (inboard electrolytic capacitor, nearest V1).	306 to 374 v dc (340 v ±10%) Must not vary more than ±2 volts as line voltage is varied from 105 to 125 v (210 to 250 v).

**3.4.3 VOLTS DC METER, M2.**

Setup. Set the autotransformer to 115 v (230 v). Turn the OVERLOAD switch OFF, short the METER SWITCH binding posts together, and connect a voltmeter across R3 and R4 (mounted on the panel, just inboard of the VOLTS DC meter).

R23 adjustment. Set the SET TO 2 VOLTS control for a voltmeter reading of exactly 2 volts. Adjust R23 (immediately behind the VOLTS DC meter) for a VOLTS DC meter reading of exactly 2. Disconnect the voltmeter.

**3.4.4 PERCENT METER, M1.**

Setup. Turn the OVERLOAD switch ON and short the METER SWITCH binding posts together.

R14 adjustment. Set the METER ZERO control to its mid-position and adjust R14 for a PERCENT meter reading of exactly 0.

Meter linearity. Disconnect the short between the METER SWITCH binding posts and connect a decade resistor to the UNKNOWN binding posts. Set the INTERNAL STANDARD to 10 kΩ, and proceed as follows:

Decade-Resistor Setting	PERCENT Meter Reading
12 kΩ	+20 exactly, adjust by means of R5.
11.5 kΩ	+15 ±0.5 division
11 kΩ	+10 ±0.5 division
10.5 kΩ	+5 ±0.5 division
10 kΩ	0 ±0.5 division
9.5 kΩ	-5 ±0.5 division
9 kΩ	-10 ±0.5 division
8.5 kΩ	-15 ±0.5 division
8 kΩ	-20 ±0.5 division

**NOTE**

The meter zero may change during measurements, causing out-of-tolerance readings. To prevent this, reset the METER ZERO control before each measurement by shorting the METER SWITCH binding posts together and setting the METER ZERO control for a PERCENT meter reading of 0.

Disconnect the decade resistor.



### 3.4.5 OVERLOAD SWITCH.

**Setup.** Set the INTERNAL STANDARD to  $1.8\Omega$  and turn the OVERLOAD switch OFF. Short the METER SWITCH binding posts together, short the EXT STD binding posts together, and short the UNKNOWN binding posts together.

**Check.** Turn the OVERLOAD switch ON and set the SET TO 2 VOLTS control for a VOLTS DC meter reading of 2. The OVERLOAD switch must not operate (must remain ON).

Reduce the INTERNAL STANDARD setting in  $0.1\Omega$  steps. Reset the SET TO 2 VOLTS control, if necessary, to maintain a VOLTS DC meter reading of 2 and pause several seconds at each new INTERNAL STANDARD setting. The OVERLOAD switch must operate (turn OFF) at an INTERNAL STANDARD setting of between  $1.3\Omega$  and  $1.7\Omega$ . Disconnect the short between the UNKNOWN binding posts.

### 3.4.6 SWITCH RESISTANCE COMPENSATION.

**Setup.** Set the INTERNAL STANDARD to zero and connect a 1-ohm resistor to the EXT STD binding posts. Connect another 1-ohm resistor (matched to within 0.1% of the first) to the UNKNOWN binding

posts. Turn the OVERLOAD switch ON, set the SET TO 2 VOLTS control for a VOLTS DC meter reading of 2, and reset the METER ZERO control.

**R21 adjustment.** Disconnect the short between the METER SWITCH binding posts; the PERCENT meter must read 0. If it doesn't, R21 requires readjustment.

**R21 is not a normal potentiometer.** The resistance element is a length of resistance wire connected between the  $0.1\Omega$ /STEP switch and the upper UNKNOWN terminal. The wiper arm is simply a wire soldered to the resistance element.

To readjust R21, unsolder the wiper lead from the resistance element, move it along the element until the PERCENT meter reads 0, and then resolder it on the resistance element at that point. Disconnect the 1-ohm resistor and replace the shorting link between the EXT STD binding posts.

### 3.4.7 INTERNAL STANDARD ACCURACY.

**Procedure.** Connect the appropriate resistance across the UNKNOWN binding posts, set the INTERNAL STANDARD to the value listed, and note the PERCENT meter reading, which must be within the limits given below:

Resistance Connected to UNKNOWN Terminals	INTERNAL STANDARD Setting	PERCENT Meter Reading
1 $\Omega$	0.1 $\Omega$ /STEP set to 10	0 $\pm$ 0.5 division
10 $\Omega$	1 $\Omega$ /STEP set to 10	0 $\pm$ 0.25 division
100 $\Omega$	10 $\Omega$ /STEP set to 10	0 $\pm$ 0.15 division
100 $\Omega$	100 $\Omega$ /STEP set to 1	0 $\pm$ 0.15 division
1 k $\Omega$	100 $\Omega$ /STEP set to 10	0 $\pm$ 0.15 division
1 k $\Omega$	1 k $\Omega$ /STEP set to 1	0 $\pm$ 0.15 division
10 k $\Omega$	1 k $\Omega$ /STEP set to 10	0 $\pm$ 0.15 division
10 k $\Omega$	10 k $\Omega$ /STEP set to 1	0 $\pm$ 0.15 division
100 k $\Omega$	10 k $\Omega$ /STEP set to 10	0 $\pm$ 0.15 division
100 k $\Omega$	100 k $\Omega$ /STEP set to 1	0 $\pm$ 0.15 division
1 k $\Omega$	100 k $\Omega$ /STEP set to 10	0 $\pm$ 0.15 division





## PARTS LIST

REF NO.	DESCRIPTION	PART NO.
C1	CAPACITOR, Electrolytic, 3000 $\mu$ f 10 v	4450-0700
C2	CAPACITOR, Electrolytic, 100 $\mu$ f 450 v	4450-0800
C3	CAPACITOR, Oil, 0.047 $\mu$ f $\pm$ 10%	4510-4200
C4	CAPACITOR, Oil, 0.1 $\mu$ f $\pm$ 10%	4510-4500
F1	FUSE, 0.3 a for 115-v operation	5330-0800
	FUSE, 0.15 a for 230-v operation	5330-0500
F2	FUSE, 0.3 a for 115-v operation	5330-0800
	FUSE, 0.15 a for 230-v operation	5330-0500
M1	METER, 200 $\mu$ a	5730-1060
M2	METER, 200 $\mu$ a	5730-1072
P1	PILOT LAMP, Mazda #44	5600-0700
PL1	PLUG, Input	4240-0700
R1	POTENTIOMETER, 2.5 $\Omega$ $\pm$ 5%	0214-0010
R2	RESISTOR, Power, 0.5 $\Omega$ $\pm$ 10% 10 w	6640-8509
R3	RESISTOR, Precision, 1 k $\Omega$ $\pm$ 0.1%	6700-0501
R4	RESISTOR, Precision, 1 k $\Omega$ $\pm$ 0.1%	6700-0501
R5	POTENTIOMETER, Wire-wound 1 k $\Omega$ $\pm$ 5%	0973-4160
R6	RESISTOR, Film, 2 M $\Omega$ $\pm$ 1% 1/2 w	6450-4200
R7	RESISTOR, Composition, 360 k $\Omega$ $\pm$ 5% 1/2 w	6100-4365
R8	RESISTOR, Composition, 360 k $\Omega$ $\pm$ 5% 1/2 w	6100-4365
R9	RESISTOR, Film, 2 M $\Omega$ $\pm$ 1% 1/2 w	6450-4200
R10	RESISTOR, Composition, 1 M $\Omega$ $\pm$ 10% 1/2 w	6100-5105
R11	RESISTOR, Film, 825 k $\Omega$ $\pm$ 1% 1/2 w	6450-3825
R12	RESISTOR, Composition, 220 k $\Omega$ $\pm$ 5% 1/2 w	6100-4225
R13	RESISTOR, Film, 825 k $\Omega$ $\pm$ 1% 1/2 w	6450-3825
R14	POTENTIOMETER, Wire-wound 50 k $\Omega$ $\pm$ 5%	0973-4170
R15	RESISTOR, Film, 249 k $\Omega$ $\pm$ 1% 1/2 w	6450-3249
R16	RESISTOR, Composition, 100 $\Omega$ $\pm$ 10% 1/2 w	6100-1105
R17	POTENTIOMETER, 1 k $\Omega$ $\pm$ 5%	0973-3911
R18	RESISTOR, Composition, 100 $\Omega$ $\pm$ 10% 1/2 w	6100-1105
R19	RESISTOR, Film, 249 k $\Omega$ $\pm$ 1% 1/2 w	6450-3249
R20	RESISTOR, Wire-wound, 15 $\Omega$ $\pm$ 10% 1/2 w	7510-1930 (part of)
R21	RESISTOR, 0.03 $\Omega$ $\pm$ 10%	1652-0820
R22	RESISTOR, Composition, 47 k $\Omega$ $\pm$ 5% 1/2 w	6100-3475
R23	POTENTIOMETER, Wire-wound 2.5 k $\Omega$ $\pm$ 10%	6050-1500
R24	RESISTOR, Film, 13 k $\Omega$ $\pm$ 1%	6250-2130
RX1	RECTIFIER	6080-0800
RX2	RECTIFIER	6080-0800
S1	DECADE RESISTOR	0510-4670
S2	DECADE RESISTOR	0510-4060
S3	DECADE RESISTOR	0510-4650
S4	DECADE RESISTOR	0510-4050
S5	DECADE RESISTOR	0510-4630
S6	DECADE RESISTOR	0510-4640
S7	DECADE RESISTOR	0510-4610
S8	SWITCH, Toggle	7910-1300
S9	CIRCUIT BREAKER, 1.2 a	5320-0300
T1	VOLTAGE REGULATOR	6750-0200
V1	TUBE, Type 6X4	8360-8100
V2	TUBE, Type 6SU7-GTY	8360-7400
V3	TUBE, Type 6SU7-GTY	8360-7400



INTERNAL STANDARD-MINIMUM SETTING 1 OHM

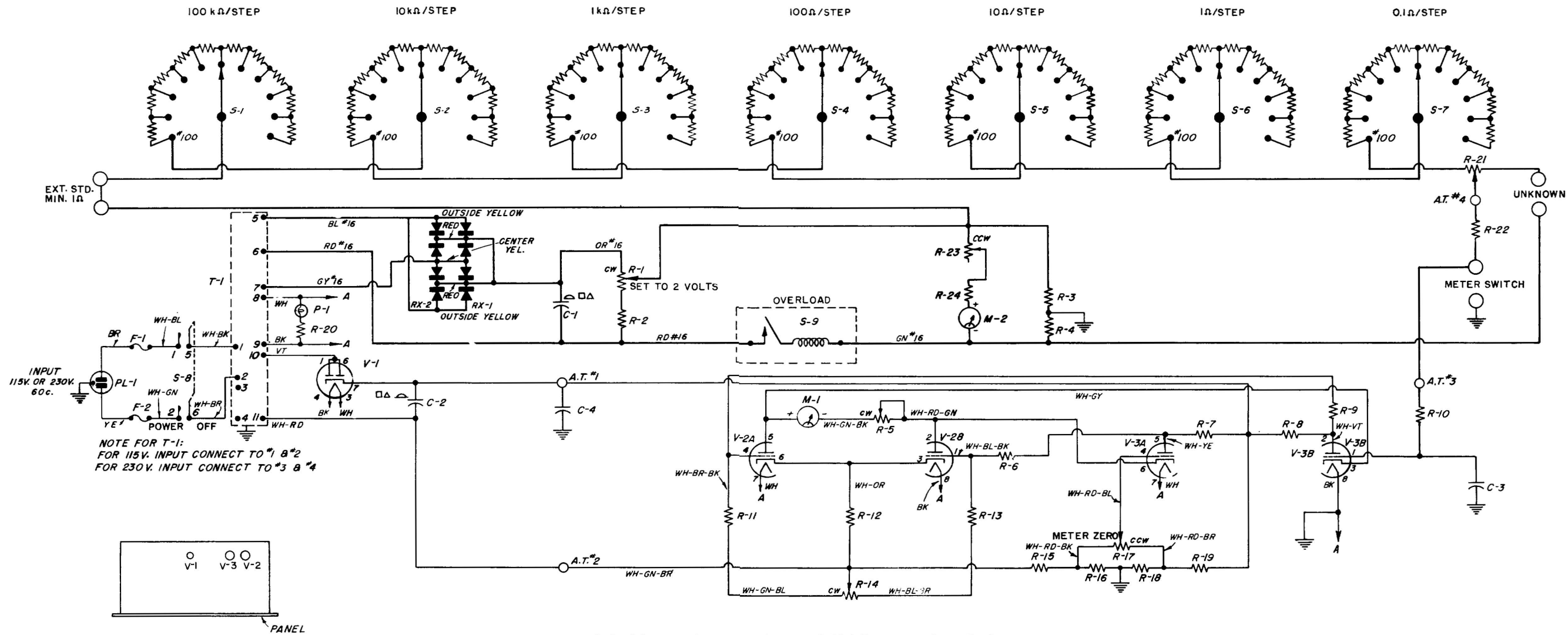
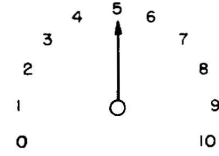
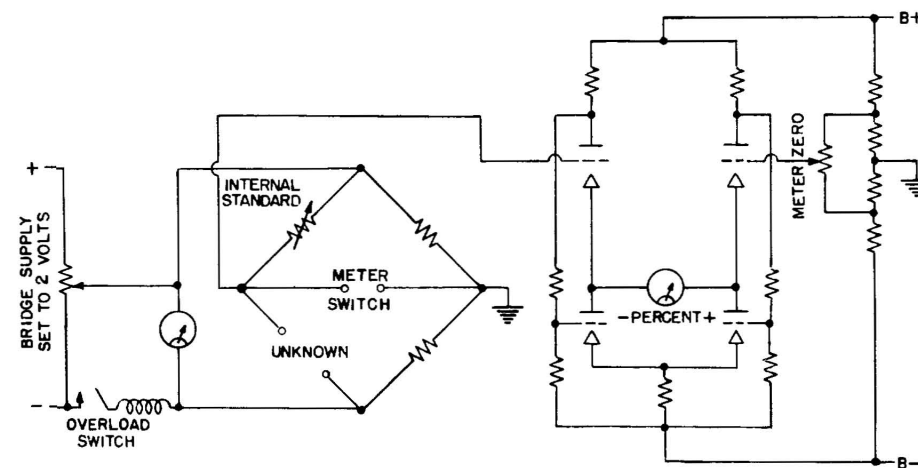

Figure 3-1. Schematic diagram for the Type 1652-A Resistance Limit Bridge.

TUBE LAYOUT

Figure 3-2. Elementary schematic diagram for the Type 1652-A Resistance Limit Bridge.





# GENERAL RADIO COMPANY

WEST CONCORD, MASSACHUSETTS

EMerson 9-4400

Clearwater 9-8900

## DISTRICT OFFICES

### NEW YORK

Broad Ave. at Linden, Ridgefield, N. J.  
Telephone N.Y. WOrth 4-2722  
N.J. WHitney 3-3140

### PHILADELPHIA

1150 York Rd., Abington, Penna.  
Telephone HANcock 4-7419

### WASHINGTON

8055 13th St., Silver Spring, Md.  
Telephone JUniper 5-1088

### CHICAGO

6605 West North Ave., Oak Park, Ill.  
Telephone Village 8-9400

### LOS ANGELES

1000 N. Seward St., Los Angeles 38,  
Calif.  
Telephone HOLlywood 9-6201

### SAN FRANCISCO

1186 Los Altos Ave., Los Altos, Calif.  
Telephone WHitecliff 8-8233

### CANADA

99 Floral Pkwy., Toronto 15, Ont.  
Telephone CHerry 6-2171

## REPAIR SERVICES

### EAST COAST

General Radio Company  
Service Department  
22 Baker Ave., W. Concord, Mass.  
Telephone EMerson 9-4400

### NEW YORK

General Radio Company  
Service Department  
Broad Ave. at Linden, Ridgefield, N. J.  
Telephone N.Y. WOrth 4-2722  
N.J. WHitney 3-3140

### MIDWEST

General Radio Company  
Service Department  
6605 West North Ave., Oak Park, Ill.  
Telephone VIllage 8-9400

### WEST COAST

General Radio Company  
Service Department  
1000 N. Seward St., Los Angeles 38, Calif.  
Telephone HOLlywood 9-6201

### CANADA

Bayly Engineering, Ltd.  
First Street, Ajax, Ontario  
Telephone Toronto EMpire 2-3741

Printed in USA

