

# OPERATING INSTRUCTIONS

for

## TYPE 1601-A V-H-F BRIDGE

Form 721-A



**GENERAL RADIO COMPANY**

**CAMBRIDGE 39**

**MASSACHUSETTS**

**NEW YORK**

**CHICAGO**

**LOS ANGELES**

**U. S. A.**



# Specifications

**Frequency Range:** 10 Mc to 165 Mc. Satisfactory operation can, for some measurements, be obtained at frequencies as low as 2 Mc and as high as 175 Mc, but the bridge sensitivity decreases markedly at frequencies beyond the nominal range of 10 to 165 Mc. In addition, the accuracy of measurement of small reactances decreases as the frequency decreases, owing to lack of precision in reading the reactance dial, whose range is inversely proportional to frequency, and at frequencies above the nominal range the corrections become larger.

**Reactance Range:** +200 ohms at 100 Mc. Dial range varies inversely with frequency and is calibrated at 100 Mc.

**Resistance Range:** 0 to 200 ohms, independent of frequency.

**Accuracy:** For resistance,  $+(2\% + 1\Omega)$  subject to correction for inductance in the capacitor used to measure resistance. The correction increases with frequency and the magnitude of the resistive component. A correction chart is supplied with the instrument. The ohmic uncertainty indicated in the accuracy statement, namely 1 ohm, is roughly proportional to the magnitude of the reactive component of the unknown impedance. The indicated value is the maximum obtainable, and the minimum is 0.1 ohm.

For reactance,  $+(5\% + 2\Omega)$ . The ohmic uncertainty is roughly proportional to frequency and to the magnitude of the resistive component. The maximum value is indicated and the minimum value is 0.1 ohm at 100 Mc.

**Accessories Supplied:** Two Type 874-R20 Cables; one Type 1601-204 Coaxial Extension Assembly; one Type 874-WN Short Circuit.

**Other Accessories Required:** R-F generator and receiver covering the desired frequency range; Type 1208-A Oscillator is recommended for frequencies above 65 Mc, and, for lower frequencies, the Type 1330-A Bridge Oscillator. Both oscillator and receiver should be reasonably well shielded.

**Additional Accessories Recommended:** A Type 874-WM 50-ohm Termination is useful in checking the bridge. The bridge is equipped with Type 874 Coaxial Connectors, and if connection is to be made to equipment using Type N Connectors, Type 874-Q1 Adaptors will be needed.

**Dimensions:** (Length) 13-1/2 x (height) 9 x (depth) 10-1/2 inches, overall.

**Net Weight:** 17-1/2 pounds.

U. S. Patent Nos. 2,376,394, 2,125,816, and 2,548,457

# OPERATING INSTRUCTIONS

for

## TYPE 1601-A V-H-F BRIDGE

### SECTION 1.0 DESCRIPTION

#### 1.1 GENERAL DESCRIPTION

The Type 1601-A V-H-F Bridge is a null instrument for use in measuring the impedance of coaxial-line and lumped-constant circuits at frequencies between 10 and 165 Mc. Measurements can be made with decreased accuracy at frequencies somewhat below and above these nominal frequency limits.

The bridge is used with a series-substitution method for measuring an unknown impedance,  $Z_x$ , in terms of its series resistance component,  $R_x$ , and series reactance component  $X_x$ . The resistance is read from a variable-capacitor dial directly calibrated in resistance in ohms. The reactance is read from a variable-capacitor dial directly calibrated in reactance in ohms at a frequency of 100 Mc. The resistance dial reading is independent of frequency, and the reactance dial reading increases linearly with frequency. For frequencies other than 100 Mc the reactance dial reading must therefore be divided by the operating frequency in hundreds of megacycles. The resistance dial reads from 0 to 200 ohms; the reactance dial from 0 to 230 ohms at 100 Mc. A coaxial connector can be mounted directly on the bridge for coaxial-line measurements, and a pair of terminals or a single terminal and a ground plane are provided for measurements on other types of circuits.

#### 1.2 BASIC CIRCUIT AND BALANCE CONDITIONS

The basic circuit used is shown in Figure 1.

A measurement is made by first balancing the bridge with the UNKNOWN terminals short-circuited; then rebalancing with the short-circuit removed and the unknown impedance connected to the UNKNOWN terminals.

When the UNKNOWN terminals are short-circuited, the bridge balance conditions are:

$$R_P = \frac{R_B}{C_N} C_{A1} \quad (1)$$

$$X_{P1} = \frac{-1}{\omega C_{P1}} = \frac{-R_B}{\omega C_N} \frac{1}{R_A} \quad (2)$$

When the short-circuit is replaced by the unknown impedance,  $Z_x = R_x + jX_x$ , the new balance equations are:

$$R_P + R_x = R_B \frac{C_{A2}}{C_N} \quad (1a)$$

$$X_{P2} + X_x = \frac{-R_B}{\omega C_N} \frac{1}{R_A} \quad (2a)$$

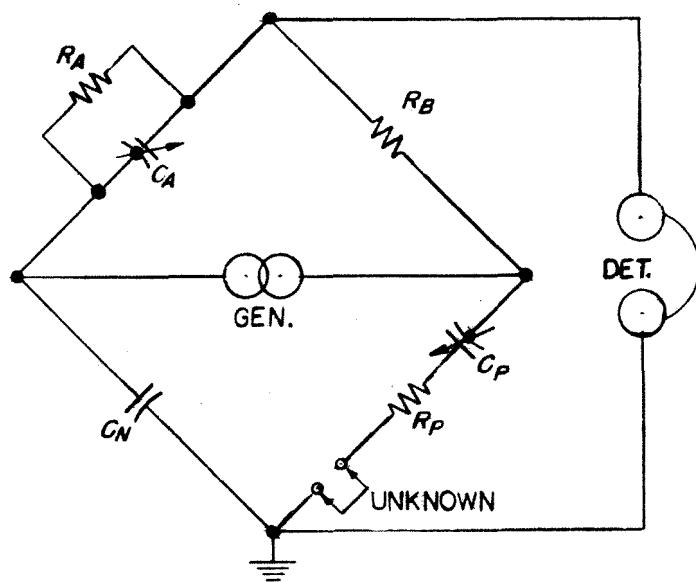

Figure 1. Basic Circuit of the Type 1601-A V-H-F Bridge.

The unknown resistance,  $R_x$ , and reactance,  $X_x$ , are therefore related to the bridge parameters by the following expressions:

$$R_x = \frac{R_B}{C_N} (C_{A2} - C_{A1}) \quad (1b)$$

$$X_x = \frac{1}{\omega} \left( \frac{1}{C_{P2}} - \frac{1}{C_{P1}} \right) \quad (2b)$$

The resistance,  $R_x$ , is seen to depend upon a change in capacitance  $C_A$ ; the reactance,  $X_x$ , upon a change in capacitance  $C_P$ . The constant relating the resistance,  $R_x$ , to the change in capacitance,  $C_A$ , is determined by the fixed resistance,  $R_B$ , and the fixed capacitance,  $C_N$ . The reactance,  $X_x$ , is equal to the change in reactance of the capacitor,  $C_P$ , and is opposite in sign.

### 1.3 COMPLETE CIRCUIT

Figure 2 is a complete circuit diagram of the bridge.

Through the series-substitution method of measurement, simple relationships between the unknown resistance and reactance and increments of capacitance are obtained. In order to extend this simplicity of analysis to simplicity of operation, auxiliary controls not shown in the basic diagram of Figure 1 have been added. Their functions are most easily described when the resistance and reactance balances are considered separately.

The dial of the variable capacitor,  $C_A$ , that is used for resistance measurement, can be calibrated in resistive ohms with any capacitance setting chosen as zero. For maximum resistance range, this setting is chosen at minimum capacitance. A small trimmer capacitance,  $C_A'$ , is then connected in parallel with the resistance capacitor,  $C_A$ , so that the initial resistance balance with the UNKNOWN terminals short-circuited can be made at zero dial reading irrespective of slight changes in the bridge parameters with time or frequency.

The dial of the variable capacitor,  $C_P$ , used for the reactance measurement can be calibrated in reactive ohms at any one frequency, again with any capacitance

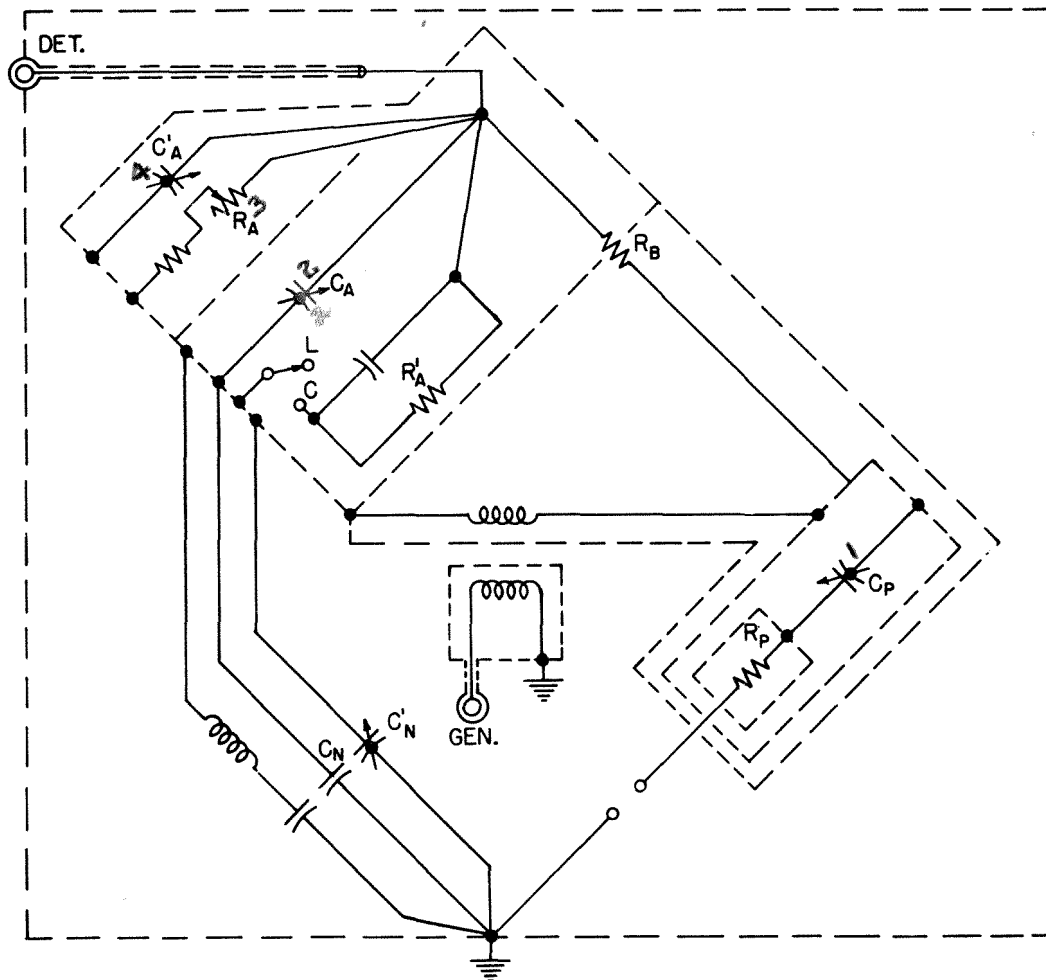

Figure 2. Complete Circuit of the Type 1601-A V-H-F Bridge.

setting chosen as zero. For maximum reactance range and best scale distribution, this setting is chosen at maximum capacitance.

As shown in Equations (1), (1b), (2), and (2b) the resistance  $R_A$  affects only the initial reactance balance and has no effect on either the resistance or reactance dial calibrations. Therefore, the resistor  $R_A$  can be made variable to allow the reactance dial to be initially set at zero or any other desired setting, irrespective of changes in the bridge parameters with time or frequency. Actually  $R_A$  is used only as a coarse initial balance control, as it is a carbon potentiometer, and the fine initial reactance balance made with the calibrated reactance capacitor,  $C_p$ . With the zero position of the reactance dial established at maximum capacitance, the dial scale reads inductive reactance directly; for measurements of capacitive reactance, the initial balance must be made at an upscale reading so that the negative change in dial reading will remain on scale. In order to obtain maximum capacitive-reactance range and yet keep the range of the variable resistor,  $R_A$ , small to allow the maximum fineness of adjustment, a two-position switch is provided which allows a small fixed resistor to be connected in parallel with the variable resistor when an initial balance near the upper end of the reactance dial scale is desired. With the switch set in the L position, an initial balance can be obtained over the lower portion of the main reactance dial for measuring inductive reactances and small capacitive reactances; with it set in the C position a balance can be obtained over a section of the dial near its upper end for measuring large capacitive reactances.

The small variable capacitance  $C_N$  is used to adjust the resistance dial calibration and the series L-C circuit connected in parallel with  $C_N$  is used to partially compensate for the effects of inductance in the resistance capacitor,  $C_A$ .

#### 1.4 PANEL LAYOUT AND CONTROLS

The controls, plainly marked on the panel, are:

(1) The variable capacitor,  $C_p$ , used to measure reactance, X. The four-inch dial of this capacitor is calibrated from 0 to 230 ohms at a frequency of 100 Mc. For precise setting it is provided with a small vernier knob, X, located at the left side of the panel.

(2) The variable capacitor,  $C_A$ , used to measure resistance R. The four-inch dial of this capacitor is calibrated from 0 to 200 ohms at a frequency of 100 Mc. It is provided with a small vernier knob R located at the right side of the panel.

(3) The variable resistor,  $R_A$ , used to make the coarse INITIAL reactance BALANCE. The knob, X, controlling this resistor is located in the lower left center section of the panel just below the nameplate.

(4) The variable capacitor,  $C_A'$ , used to make the INITIAL resistance BALANCE when the resistance dial

is set at 0 ohms. The knob, R, controlling this capacitor is located just to the right of the INITIAL reactance BALANCE knob.

(5) The two-position switch used to establish the initial balance setting of the reactance dial in the region about 0 or 200 ohms. This switch is located in the center of the panel between the two dials. The two positions are marked L and C to indicate that the first is to be used when measuring inductive reactances and the second is to be used when measuring large capacitive reactances. (See Paragraph 2.6.)

The two Type 874 Coaxial Connectors for the generator and detector connections to the bridge are marked GEN and DET on the panel.

The unknown terminals are located on the top of the bridge directly above the R and X dials. The ground connection to the unknown may be made at any convenient point on the metal ground plate covering part of the top of the instrument. A number of tapped holes are provided to facilitate the making of low inductance connections to the ground plate. The ungrounded terminal is mounted on a high-temperature polystyrene insulator. Connection to 50-ohm coaxial-line circuits can be made by mounting the adaptor supplied directly on the bridge terminals.

#### 1.5 ACCESSORIES SUPPLIED

1.51 Short-Circuiting Cap: A threaded cap with a knob attached is provided to short-circuit the unknown terminals for setting up the initial balance. The cap screws into the ground plate on the top side of the bridge and contacts the ungrounded terminal, thus providing a very low-inductance short-circuit across the bridge terminals.

1.52 Coaxial Adaptor: For measurements on coaxial-line circuits having a 50-ohm characteristic impedance, an adaptor with a Type 874 Connector on one end can be mounted directly on the bridge. The center conductor of the adaptor screws into the ungrounded bridge terminal while the outer shell is clamped to the ground plate of the bridge. The adaptor acts as a short length of 50-ohm coaxial transmission line with all capacitance fringing effects at the bridge end of the adaptor compensated for by a short section of line having a higher inductance than that required for a line with a 50-ohm characteristic impedance. A standard Type 874-WN Short-Circuit is also provided for setting up the initial balance when the coaxial adaptor is used. Type 874-Q1 Adaptors from Type 874 Connectors to Type N Connectors are available but not supplied.

1.53 Cables: Two 50-ohm Coaxial Cables, Type 874-R20, are supplied for connection to the generator and detector. Both of these cables have Type 874 Connectors on either end. Adaptors are available to both Type N and General Radio Type 774 Connectors; Type 874-Q1 Adaptor for Type 874 to Type N, and Type 874-Q7 Adaptor for Type 874 to Type 774. Coaxial connectors should be used at all junctions to minimize leakage effects. (See Paragraph 2.4.)

# GENERAL RADIO COMPANY

## SECTION 2.0 OPERATION

### 2.1 GENERATOR

Any well-shielded radio-frequency oscillator having an output voltage of the order of 1 to 30 volts and adequate frequency stability will serve as a generator. The oscillator output voltage required for satisfactory operation depends on the output impedance of the generator, the frequency, the sensitivity of the detector, and the impedance measured. The oscillator voltage requirements can be estimated from the sensitivity information contained in Paragraph 2.3. Signal sources such as the General Radio Type 1001-A, Type 805-C, and Type 1021-A Standard-Signal Generators, the General Radio Type 1208 Unit Oscillator, and various field strength meters in most cases are satisfactory over their respective ranges.

The generator should be provided with completely shielded coaxial connectors or leakage difficulties may arise. (See Paragraph 2.4.) In this regard the Type 805-C Standard-Signal Generator should be operated with its terminating unit removed, that is with the Type 874-R20 Cable connected directly to the Type 774 Jack on the panel of the generator by means of a Type 874-Q7 Adaptor.

### 2.2 DETECTOR

Any well-shielded receiver having a sensitivity of

the order of a microvolt or so will serve as a detector. The detector sensitivity required for adequate operation is related to the bridge sensitivity, frequency, detector input impedance, impedance under test, and the generator output voltage. The exact relationships can be determined from Paragraph 2.3. However, in most cases, communications receivers such as the Hallicrafter Types SX-27 and 28 and National Types 173 and 200, and service receivers such as the APR-1 and APR-4 are useful over their respective tuning ranges. The communications receivers mentioned should be provided with coaxial connectors mounted on their cases in place of the standard terminal board to eliminate difficulties due to leakage. (See Paragraph 2.4.)

It is recommended that the receiver be provided with an adequate r-f or i-f sensitivity control.

### 2.3 SENSITIVITY

The sensitivity,  $S$ , of the bridge is defined as the output voltage in microvolts developed across the DETECTOR terminals per ohm deviation of either resistance or reactance from the true balance condition, with one volt applied across the GENERATOR terminals. Figure 3 shows the variation in the open-circuit sensitivity,  $S_0$ , as a function of frequency. The open-circuit sensitivity is the sensitivity obtained with an infinite impedance detec-

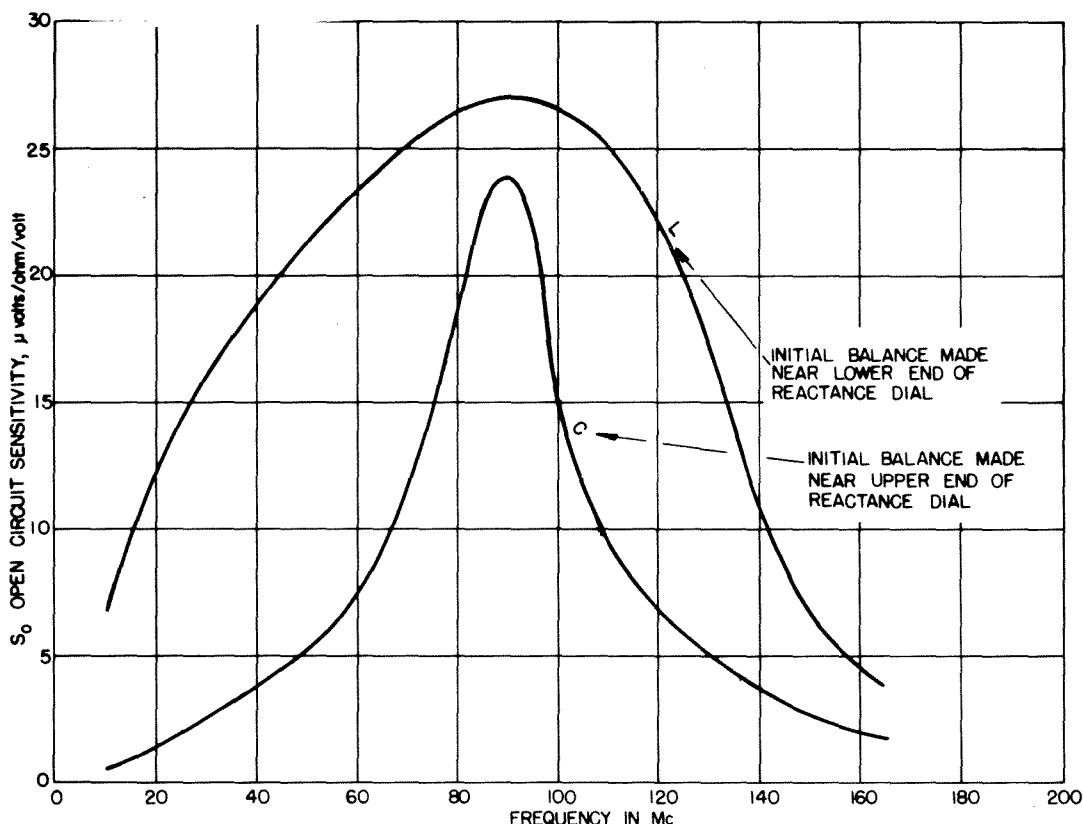

Figure 3. Plot of Open-Circuit Sensitivity versus Frequency.

tor. The actual sensitivity,  $S$ , with a finite impedance detector is:

$$S = S_0 \frac{Z_d}{Z_d + Z_0} \quad (3)$$

where  $Z_d$  is the complex impedance of the detector and  $Z_0$  is the complex impedance seen looking into the DETector terminals of the bridge. Figure 4 shows the variation in the DETector terminal impedance with frequency.

The voltage,  $E_i$ , actually developed across the generator terminals by a generator having an open-circuit voltage,  $E_g$ , and a complex output impedance,  $Z_g$ , is:

$$E_i = E_g \frac{Z_i}{Z_g + Z_i} \quad (4)$$

where  $Z_i$  is the complex impedance seen looking into the GENERator terminals. The GENERator terminal impedance is plotted as a function of frequency in Figure 5.

The actual voltage,  $E_o$ , is developed across the DETector terminal per ohm of unbalance is then:

$$E_o = SE_i \quad (5)$$

### 2.4 R-F LEAKAGE AND GROUNDING -

2.41 R-F Leakage: Errors in the measurements can be caused by stray couplings between the generator and receiver, generator and circuit under test, or the circuit under test and the receiver. In order to obtain a balance with a stray coupling present the bridge must supply a voltage equal to and  $180^\circ$  out of phase with the leakage voltage. In order to obtain this bucking voltage the bridge must be unbalanced slightly from true balance, which may cause errors in the measurement. The most common sources of leakage are: 1) lack of complete coaxial shielding in leads from the generator to the bridge and the bridge to the receiver, 2) poorly filtered a-c power leads in oscillator or receiver, 3) poorly shielded oscillator or receiver.

Figure 4. Detector Terminal Impedance Plotted versus Frequency.

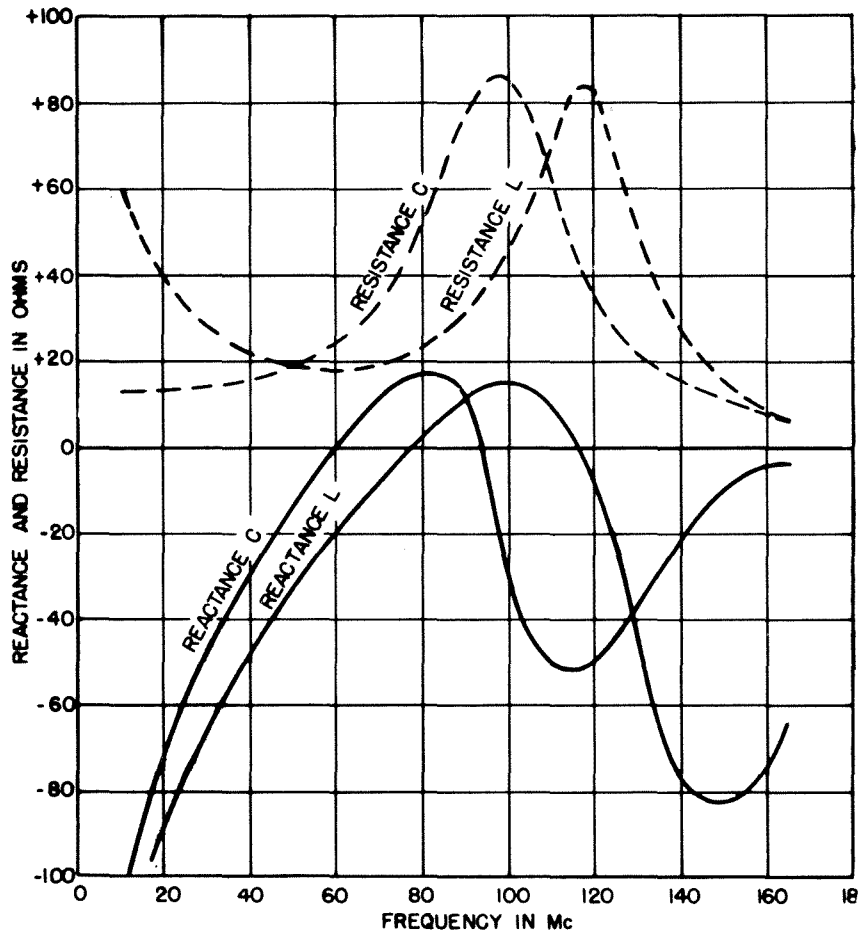

If the leads from the generator to the bridge are not completely coaxial including the connections to each, a common inductance will be present between currents flowing inside the coaxial cable and currents flowing outside. Thus as shown in Figure 6, a current,  $i$ , flowing inside the cable will produce a voltage drop,  $e_s$ , across the common inductance which in turn will cause current,  $i_s$ , to flow along the outside of the cable and through various parts of the bridge setup. This current can cause errors as it may couple to the bridge circuit and introduce spurious voltages in it. At high frequencies a very small inductance may have an appreciable voltage drop across it. For instance, at 100 Mc a length of #20 wire only 1/8 inch long will have a reactance of about one ohm, and if this wire is the connection between the shell of the coaxial line from the generator and the panel of the bridge, a leakage voltage of the order of one percent of the generator voltage may be developed. Therefore, it is important to use coaxial connectors at all junction points in these leads.

A common impedance between the circuit inside the coaxial cable and the circuit outside of the coaxial cable connecting the bridge and the receiver is another serious source of error. Any voltage developed across this impedance by currents flowing outside the coaxial cable introduces a spurious voltage,  $e_s$ , in series with the true unbalance signal from the bridge as shown in Figure 7 and hence causes errors. Currents,  $i_s$  and  $i_x$ , can flow along the outside of the cable due to leakage

from the generator, or from coupling to the circuit under test. Therefore, it is very important to have a completely coaxial system between the bridge and the detector with a coaxial connector mounted directly on the outer shield of the detector in place of the usual terminal boards.

Leakage can also be caused by loose joints in the coaxial system. For instance, if the coaxial panel connectors are not securely fastened to their respective panels or chassis, or if the coupling nuts on the Type 874 Connector which clamp the outer contacting member to the shell are loose, leakage voltages can be developed across these junctions. The coupling nut on the Type 874 Connector on the Type 874-R20 Coaxial Cable is a threaded ring located just under the rubber sleeve at the base of the connector and has stamped on it GENERAL RADIO CO. TYPE 874.

Leakage from a-c power cords can have effects similar to those mentioned above. Power circuits can be by-passed rather easily through the use of low-inductance mica or ceramic capacitors connected from either side of the a-c line to ground at the point of entry into the chassis.

2.42 Leakage Checks: Leakage usually can be detected by one or more of the following effects or checks:

- (1) Hand-capacity effects, that is, a change in the balance when one's hand is moved with respect to the

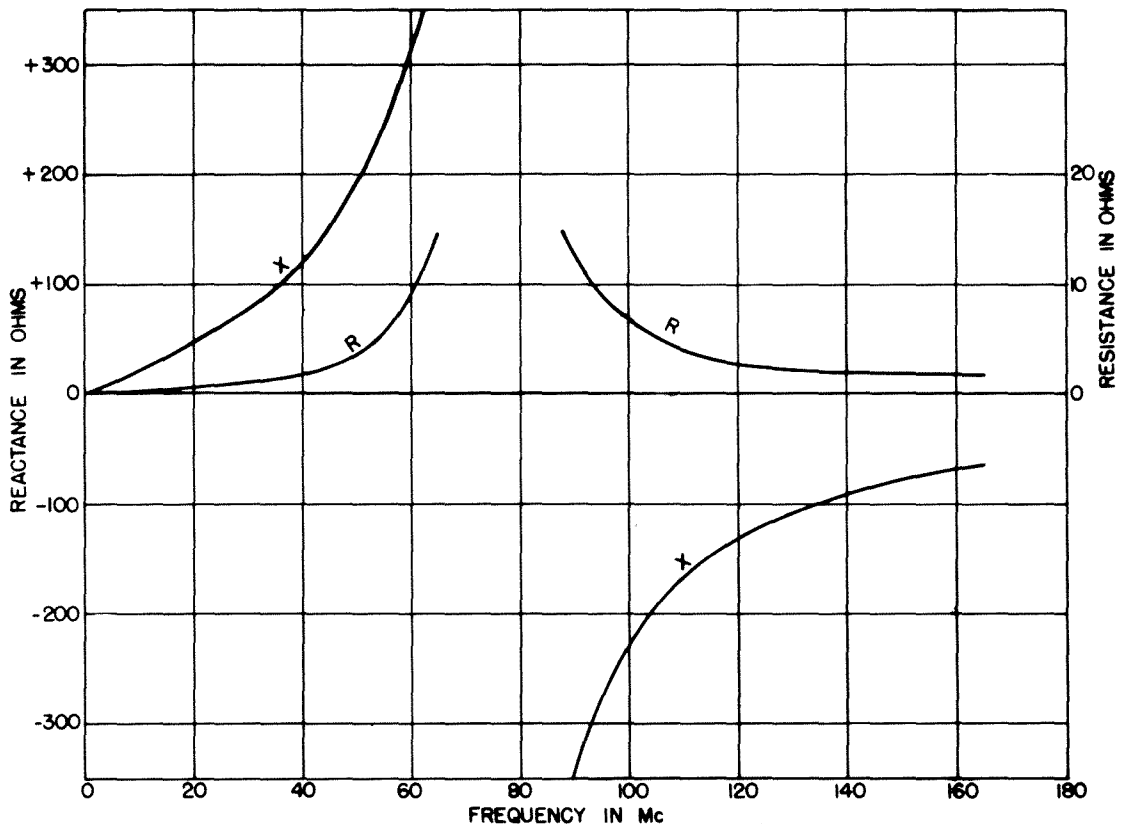

Figure 5. Generator Terminal Impedance plotted versus Frequency.



## TYPE 1601-A V-H-F BRIDGE

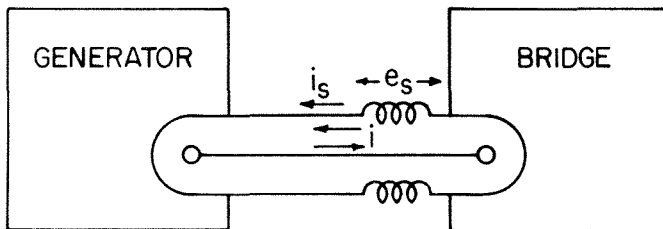

Figure 6. Sketch Showing Effect of Leakage in Coaxial Connections between Generator and Bridge.

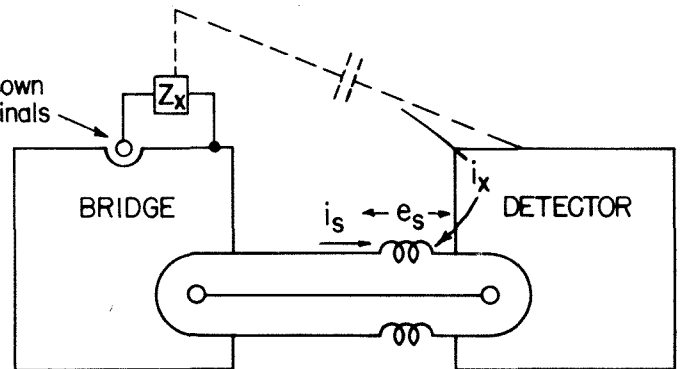

Figure 7. Sketch Showing Effect of Leakage in Coaxial Connections between Detector and Bridge.

bridge. This effect is emphasized if the bridge itself is touched or one's hand is run along either the generator or detector cable.

(2) With the bridge balanced and the unknown circuit connected, withdraw the cable connector inserted in the detector terminal on the bridge and touch only the outer shell of the connector on the cable to the outer shell of the connector on the bridge panel. No signal should be detected by the receiver under these conditions.

(3) Repeat the above check using the generator cable.

(4) Measure the unknown with circuit connected in the normal manner. Then reverse the generator and detector leads, that is, plug the cable from the generator into the terminals labeled DETECTOR and the cable from the receiver into the terminals labeled GENERATOR. The same results should be obtained in both measurements if leakage is negligible.

**2.43 Grounding:** In most cases grounding of any of the components is unnecessary. However, in some cases in which a radiating circuit is measured, the connecting of all the components to a large metal sheet with wide, low-inductance, copper straps may be helpful in reducing the coupling between the circuit under test and the components of the measuring setup.

### 2.5 COAXIAL ADAPTOR INSTALLATION

The coaxial adaptor provided for connection to 50-ohm coaxial circuits fitted with Type 874 Connectors (or with appropriate adaptors, see Paragraph 1.52) can be mounted on the bridge by first screwing the center conductor into the ungrounded bridge terminal and then fastening the shell to the ground plate by means of the threaded clamp mounted on the adaptor.

### 2.6 INITIAL BALANCE

To make an initial balance the unknown terminals must be short-circuited. If the terminals themselves

<sup>1</sup>See Paragraph 2.712 for other methods of making a short circuit for the initial balance.

are to be used, the short-circuit can be made with the threaded cap provided.<sup>1</sup> The cap is screwed into the ground plate until the center of the cap contacts the ungrounded terminal. The arrow on the knob is provided to aid in starting the threads. The cap should be seated on the threads with the arrow pointing toward the screw at the left hand edge of the hole. In this position the threads will engage with a slight clockwise turn of the knob.

If the coaxial adaptor is mounted on the terminals, the initial short-circuit may be made by inserting the Type 874-WN Short-Circuit into the connector on the end of the adaptor, or by removing the adaptor and screwing in the threaded cap referred to in the previous paragraph.

If the circuit to be measured is known to have an inductive reactance, in which case the final reactance dial reading will be larger than the initial reading, set the L-C switch to the L position, the resistance dial to zero and the reactance dial to 1 or 2. Roughly balance to a null by adjusting the two INITIAL BALANCE knobs. For a fine balance use the calibrated reactance dial and the right-hand INITIAL BALANCE knob, R, which is the initial resistance balance control. The initial reactance balance control is not suited for fine balancing as it is a carbon potentiometer and is difficult to set precisely to a given resistance. If the circuit to be measured has a large capacitive reactance component, in which case the final reactance dial reading will be smaller than the initial reading, set the L-C switch in the C position, the resistance dial at zero, the reactance dial around 200 and proceed in the manner outlined previously.

Since reactance is measured by the substitution method, the reactance dial can be initially set at any desired point within the range of the initial balance controls without causing errors. For instance, if the sign of the unknown reactance is undetermined, it may be advisable to set the reactance dial at some point above zero so the dial can be moved in either direction. In the general case a setting as close to the middle of the reactance dial range as possible is the most advantageous as it gives a relatively large inductive and capacitive reactance range. Even if the reactance is greater than that measurable with this initial setting of the reactance dial, an indication of the direction in which the dial

must be turned can be obtained if the receiver sensitivity control is turned down, and a new initial balance made accordingly. Of course, if the reactance is found to be relatively small, greater accuracy for both inductive and capacitive reactances can be obtained by initially setting the reactance dial as close to zero as possible as the scale is spread out in this region and the dial reading accuracy is greater.

Figure 8 shows the range over which the reactance dial may be set for the initial balance as a function of frequency.

In finding a balance it is particularly desirable to use a receiver that has a good r-f or i-f sensitivity control. If the receiver gain is set too high, there is a tendency for the receiver output to increase as balance is approached, and if the resistance balance is not set approximately correctly it becomes quite difficult to find the reactance balance or vice versa. When the r-f or i-f sensitivity control is set to minimum sensitivity, no difficulty should be found in making a rough balance. As balance is approached, the receiver sensitivity can be increased to improve the precision of setting. For the first rough balance the generator signal can be modulated and the receiver beat oscillator turned off. The precise balance, however, should be made with the generator unmodulated, using the beat oscillator in the receiver to produce an audible tone or the carrier level meter on the receiver. If an adequate r-f or i-f sensitivity control in the receiver is not available, it is sometimes possible to accomplish the same general results by reducing the generator output, rather than the receiver sensitivity. For the precise balance, the generator output should preferably be set at maximum so that the ratio of useful output to leakage is as great as possible. In some receivers the set must be retuned to achieve maximum sensitivity as the signal level is changed because the change in current drawn by the i-f amplifier stages with signal level may change the center frequency of the i-f amplifier or the frequency of the local oscillator.

## 2.7 MEASUREMENT OF UNKNOWN IMPEDANCE

2.71 Measurements Using Bridge Terminals: Short-circuit the bridge terminals using the threaded cap or other means<sup>2</sup> and set up an initial balance as described in Paragraph 2.6. Then remove the short-circuit and connect the circuit to be measured between the ungrounded terminal and the ground plate. The connections between the circuit under test and the ground plate should be made with as short leads as possible as the bridge measures the total impedance connected across its terminals and the inductive reactance of the leads may be appreciable.<sup>2</sup> After the unknown circuit is connected rebalance the bridge using the reactance and resistance dial controls.

The unknown resistance is read directly from the resistance dial; the unknown reactance is equal to the

difference between the final and initial settings of the reactance dial divided by the frequency in hundreds of megacycles (50 Mc = 0.5 dKMc). At 100 Mc the difference between the two readings is directly equal to the reactance. If the final dial reading is larger than the initial reading, the unknown reactance is inductive. If it is small, the unknown reactance is capacitive.

2.711 Measurements of Impedances outside Direct-Reading Range of Bridge; If the resistance or reactance component of the unknown impedance falls outside the direct-reading range of the bridge, indirect measurements can be made through the use of an auxiliary parallel capacitor.

When a pure reactance,  $jX_a$ , is connected in parallel with the unknown impedance,  $Z_x = R_x + jX_x$ , the effective input impedance,  $Z_e = R_e + jX_e$ , becomes:

$$R_e = \frac{R_x X_a^2}{R_x^2 + (X_x + X_a)^2} \quad (6)$$

$$X_e = \frac{X_a R_x^2 + X_x (X_x + X_a)}{R_x^2 + (X_x + X_a)^2} \quad (7)$$

As  $X_a$  is made smaller, these equations approach zero in the limit according to the relations:

$$R_e = X_a^2 \frac{R_x}{R_x^2 + X_x^2} \quad (8)$$

$$X_e = X_a \quad (9)$$

"Shunting down" a high impedance with a parallel capacitor will, accordingly, bring either or both the resistance and reactance components within the measurement range of the bridge.

To measure a high impedance by this method, establish an initial balance as described in Paragraph 2.6, then connect the capacitor directly across the bridge terminals and measure the capacitive reactance,  $X_a$ , of the auxiliary capacitor as described in Paragraph 2.71. Connect the circuit to be measured across the terminals in parallel with the auxiliary capacitor and measure the effective impedance,  $Z_e = R_e + jX_e$ , of the combination. The unknown impedance can then be found from the relations:

$$R_x = \frac{R_e}{\left(1 - \frac{X_e}{X_a}\right)^2 + \left(\frac{R_e}{X_a}\right)^2} \quad (10)$$

$$X_x = \frac{X_e - \frac{R_e^2}{X_a} - \frac{X_e^2}{X_a}}{\left(1 - \frac{X_e}{X_a}\right)^2 + \left(\frac{R_e}{X_a}\right)^2} \quad (11)$$

<sup>2</sup>See Paragraph 2.712 for a discussion of the effects of lead impedance and methods of eliminating it.

It should be noted that, since the auxiliary reactance,  $X_a$ , is capacitive, the number to be inserted for  $X_a$  in Equations (10) and (11) will be negative. The sign of the number for the effective reactance,  $X_e$ , will be positive or negative accordingly as the measured value is inductive or capacitive.

The value of the auxiliary capacitance to use is easily found by experiment. It should be kept reasonably small so that the impedances to be measured are not reduced so far that precision of the dial readings is lost, but it will not ordinarily be found critical. A value between 6  $\mu\mu f$  and 50  $\mu\mu f$  will usually be found to be adequate. The resistance,  $R_a$ , of the auxiliary capacitor is generally negligible but can be corrected for, when necessary, by subtracting from the effective resistance,  $R_e$ , of the parallel combination a resistance

$$R = R_a \frac{X_e^2 - R_e^2}{X_a^2} \quad (12)$$

The corrected value of  $R_e$  can then be substituted in Equations (10) and (11).

**2.712 Terminal Capacitance and Lead Corrections:** In common with other types of impedance measuring equipment, the bridge can only measure impedance at its own terminals. The capacitance in the bridge between the ungrounded terminal and the ground plate and the residual inductance and capacitance of any leads used to connect the unknown impedance to the bridge terminals often causes this impedance to differ from the impedance appearing at the terminals of the device under test. Under some circumstances the difference can be ignored and the measured impedance taken as the impedance of the device under test including the terminal capacitance and the leads. In most, cases, however, it is necessary to compensate for the effect of the terminal capacitance and lead impedance to obtain the desired impedance. An exact correction for the effect of such leads requires analysis as a transmission line and is laborious and cumbersome. For specific measurements, however, approximate connections will yield satisfactory accuracy.

The capacitance of the ungrounded terminal and any connecting lead to ground appears directly in parallel with the series circuit made up of the lead inductance and the impedance of the circuit under test. This capacitance has the same effect as a capacitance deliberately placed in parallel with the unknown impedance and affects both the resistive and reactive components of the unknown impedance. It can be corrected for using Equations (10) and (11) found in Paragraph 2.711. It should be noted that, since  $X_a$ , the reactance of the effective terminal capacitance, is capacitive, the number inserted for  $X_a$  in Equations (10) and (11) is negative. The capacitance of the terminal to ground is:

- Terminal alone - 1.0  $\mu\mu f$
- Terminal with 3/16 in. spacer mounted on it - 1.1  $\mu\mu f$

Figure 9 is a chart from which the reactance of the terminal capacitance at any frequency can be obtained.

Equations (10) and (11) are somewhat cumbersome to solve and a simplification of the procedure can be obtained through the use of the chart shown in Figure 10. The chart can be used directly when the terminal and lead capacitances add up to 1.1  $\mu\mu f$ .

To use the chart take the resistance,  $R_e$ , measured by the bridge and the reactance,  $X_d$ , as read from the dial before being divided by the frequency (actual difference between initial and final dial readings) and multiply the resistance by the frequency in hundreds of megacycles, thus obtaining  $fR_e$ . (If significant, both the resistance and reactance should first be corrected for residual parameters as outlined in Paragraph 2.713.) Then find the point in the  $fR_e - X_d$  plane corresponding to the values of  $fR_e$  and  $X_d$  and determine coordinates of this point in the  $r - X_c$  plane. The actual value of the unknown impedance is then:

$$R_x = rR_e \quad (13)$$

$$X_x = \frac{X_d + X_c}{f_d K M c} \quad (14)$$

This is a fairly simple procedure, and much time can be saved using it as the approximate magnitude of the correction can be determined from a quick glance at the chart thus eliminating the necessity of further calculation in many cases.

The chart can be used for other values of effective terminal capacitance,  $C_a$ , by multiplying  $fR_e$  and  $X_d$  by the ratio  $\frac{C_a}{1.1}$  before entering the chart and dividing the value of  $X_c$  obtained by the same ratio.

The additional effective terminal capacitance due to the capacitance to ground of a connecting lead can be measured in the following manner: Measure the reactance of a capacitor of the order of 6 to 10  $\mu\mu f$  connected directly across the bridge terminals. With the capacitor in place, also connect the lead from the circuit under test to the ungrounded terminal and measure the reactance of the combination with the lead disconnected from the circuit under test. The capacitance  $\Delta C_a$  to be added to the terminal capacitance is:

$$\Delta C_a = \frac{10^4}{2\pi} \left( \frac{1}{X_{d2}} - \frac{1}{X_{d1}} \right) \mu\mu f \quad (15)$$

Where  $X_{d1}$  is the actual reactance dial reading, before division by the frequency, obtained when the auxiliary capacitor alone was measured and  $X_{d2}$  is the reading obtained for the combination.

The inductance of the leads is in series with the



unknown circuit and hence must be corrected for to obtain the true value of the unknown impedance. If the short-circuit for the initial balance is made directly at the bridge terminals, the reactance of the leads must be subtracted from the measured reactance after the correction for terminal capacitance is made, if significant. The inductive reactance of the connecting leads can be determined by measuring the reactance seen by the bridge with the load end of the connecting leads connected together by means of a wide low-inductance sheet. The measured reactance is the lead reactance, if the reactance of the low-inductance sheet used to connect the leads together is negligible.

The need for correcting for the lead inductance can be eliminated in many measurements by making the short circuit for the initial balance at the load end of the leads connecting the bridge and the circuit under test. In this case the lead reactance,  $X_L$ , is absorbed in the initial balance and no correction need be made for it. However, when this method is used, the lead reactance,  $X_L$ , should be small compared to the reactance,  $X_a$ , of the terminal capacitance,  $C_a$ , as a fractional error of the order of  $\frac{2X_L}{X_a}$  is produced in both the resistive and reactive components of the unknown impedance.

**2.713 Corrections for Residual Parameters:** Frequency limits for accurate operation of radio-frequency impedance-measuring equipment are nearly always determined by residual parameters in the wiring and in the impedance elements that are not accounted for in the basic theory of operation. While these have been made extremely small in the bridge, they are still large enough to affect the performance in the upper part of the frequency range of the bridge and set the respective upper-frequency limit at about 165 Mc. The bridge readings can be corrected for these effects in the following manner.<sup>3</sup>

(a) **Correction for Inductance in the Resistance Capacitor:** The inductance in the resistance capacitor,  $C_A$ , causes the resistance dial to read low at high frequencies. A compensating circuit is included in the bridge, which reduces the magnitude of this effect and at the upper end of the frequency range over compensates and causes the resistance dial to read high. The amount of correction required depends upon the magnitude of the measured resistance component as well as the frequency. Figure 11 is a chart giving the correction factors. The measured value of the effective resistance,  $R_e$ , can be corrected by multiplying it by the factor,  $K$ , found in the chart.

$$R_e' = KR_e \quad (16)$$

where  $R_e'$  is the corrected value of the effective resistance.

<sup>3</sup>Correction for residual parameters should be made before lead and terminal corrections.

**NOTE:** Figure 11 is the correction curve for a typical instrument. Use Figure 11a for actual calculations.

(b) **Correction for Inductance in the Reactance Capacitor:** This correction is small and except for the most accurate measurements near the upper frequency limit of the bridge it can be neglected. Inductance in the reactance capacitor causes the reactance dial to read to low in magnitude. In most cases this correction is small compared to the bridge accuracy. However, to correct for it, the measured effective reactance,  $X_e$ , should be multiplied by the factor,  $A$ , found in Figure 12 corresponding to the operating frequency.

$$X_e' = AX_e \quad (17)$$

(c) **Correction for Small Stray Internal Capacitances in Bridge Circuit:** This correction is small and usually can be neglected unless the resistance of relatively low-loss reactances is to be measured. Various stray capacitances in the bridge circuit cause the measured resistance of an impedance having a large reactive component to be slightly in error. The error varies with frequency and is proportional to the magnitude of the measured reactance. In most cases the error is negligible as it amounts to a small fraction of an ohm. However, a correction chart is given in Figure 13 for this effect.

$$R_e'' = R_e' + MX_d \quad (18)$$

where  $X_d$  is the actual difference between the final and initial reactance dial readings (before division by the frequency).

**2.72 Coaxial-Line Measurements:** The coaxial adaptor supplied with the bridge makes it possible to measure the impedance of coaxial-line circuits having a 50-ohm characteristic impedance with a minimum of connection errors and corrections. The adaptor acts as an additional short section of 50-ohm transmission line connected between the bridge and the line under test. The bridge measures the impedance seen at the bridge end of this line. The impedance at any point along the transmission line can be calculated using a Smith chart or transmission-line equations from a knowledge of the impedance at the bridge end of the line and the electrical length of the line between the bridge and the point in question. Both of these quantities can be measured by the bridge.

The short-circuit for the initial balance for coaxial-line measurements can be made in two ways. In one case the short-circuit is made with the coaxial adaptor mounted on the bridge terminals, using the Type 874-WN Short-Circuit supplied, and in the second, the coaxial adaptor is removed and the threaded cap screwed in. The first method is the simplest physically, but necessitates the addition of the reactance of the section of short-circuited line to the measured reactance. The second method is slightly more difficult to carry out, but no

correction for the reactance of the adaptor is required. After the short-circuit has been made by either method, set up the initial balance as described in Paragraph 2.6. Then, if the first method is used, remove the Type 874-WN Short-Circuit and connect the circuit under test. If the second method is used, remove the threaded cap, screw in the adaptor as outlined in Paragraph 2.5, and connect the circuit under test. Then, in either case, rebalance the bridge using the resistance and reactance dial controls.

The measured resistance seen at the bridge end of the adaptor,  $R_e$ , is read directly from the resistance dial; the measured reactance,  $X_e$ , is equal to the difference between the final and initial settings of the reactance dial divided by the frequency in hundreds of megacycles. (50 Mc = 0.5 dKMc) An upscale dial reading corresponds to an inductive reactance and vice versa.

2.721 Corrections for Coaxial-Line Measurements:<sup>4</sup>

(a) Correction for Reactance of Short-Circuited Adaptor: If the initial balance is made with the adaptor mounted on the bridge and short-circuited with the Type 874-WN Short-Circuit, the reactance of the short-circuited adaptor,  $X_s$ , must be added algebraically to the measured reactance.

$$X_e' = X_e + X_s \quad (19)$$

For instance, if the measured reactance were -40 ohms and the shorted-line reactance +3 ohms, the corrected effective reactance would be  $X_e' = -40 + 3 = -37$  ohms. The reactance of the shorted adaptor can be found from the chart in Figure 14 or measured directly by the bridge.

If the initial balance is made with the adaptor removed using the threaded cap, this correction must not be made.

(b) Correction for Inductance in the Resistance Capacitor: The inductance in the resistance capacitor,  $C_A$ , causes the resistance dial to read low at high frequencies. A compensating circuit is included in the bridge, which reduces the magnitude of this effect and at the upper end of the frequency range over-compensates and causes the resistance dial to read high. The amount of correction required depends upon the magnitude of the measured resistance component as well as the frequency. Figure 11 is a chart giving the correction factors. The measured value of the effective resistance,  $R_e$ , can be corrected by multiplying it by the factor,  $K$ , found in the chart.

$$R_e' = KR_e \quad (16)$$

where  $R_e'$  is the corrected value of the effective resistance.

<sup>4</sup>No corrections need be made for terminal capacitance because the capacitance of the bridge terminal is included as part of the transmission line in the adaptor.

NOTE: Figure 11 is the correction curve for a typical instrument. Use Figure 11a for actual calculations.

(c) Correction for Inductance in the Reactance Capacitor (Usually Insignificant): Inductance in the reactance capacitor causes the reactance dial to read slightly low in magnitude. In most cases this correction is small compared to the bridge accuracy. However, if it is significant, a correction can be made by multiplying the measured reactance by the factor,  $A$ , found in Figure 12.

$$X_e' = AX_e \quad (17)$$

(d) Correction for Small Stray Internal Capacitances in Bridge Circuit: This correction is small and usually can be neglected unless the resistance of relatively low-loss reactances is to be measured. Various stray capacitances in the bridge circuit cause the measured resistance of an impedance having a large reactive component to be slightly in error. The error varies with frequency and is proportional to the magnitude of the measured reactance. In most cases the error is negligible as it amounted to a small fraction of an ohm. However, a correction chart is given in Figure 13 for this effect.

$$R_e'' = R_e' + MX_d \quad (18)$$

where  $X_d$  is the actual difference between the final and initial reactance dial readings (before division by the frequency).

2.722 Calculation of the Voltage Standing Wave Ratio, VSWR: The VSWR on the line connected to the bridge terminals can be calculated from the effective impedance,  $Z_e$ , measured by the bridge using the following equation:

$$VSWR = \frac{1 + \frac{|Z_e - Z_0|}{|Z_e + Z_0|}}{1 - \frac{|Z_e - Z_0|}{|Z_e + Z_0|}} \quad (20)$$

where  $Z_0 = 50$  ohms and the vertical lines indicate the magnitude of the complex expression enclosed, ( $Z_e$  is a complex number,  $R_e + jX_e$ ).

2.723 Determination of the Electrical Length of a Transmission Line: The electrical length of the transmission line between the bridge end of the coaxial adaptor and any other point along the line can be determined by measuring the reactance as seen by the bridge with the line short-circuited at the point in question. The reactance,  $X_e$ , measured by the bridge under these conditions is related to the electrical length of the line between the two points,  $\beta\ell$ , by the expression:

$$X_e = Z_0 \tan \beta\ell \quad (21)$$

where  $\beta$  is the phase constant and  $\ell$  the physical length

of the line. Therefore:

$$\beta l = \arctan \frac{X_e}{Z_0} \quad \text{radians} \quad (21a)$$

However,  $\arctan \frac{X_e}{Z_0}$  is a multi-valued function with an infinite number of possible values of  $\beta l$  for a single value of  $\frac{X_e}{Z_0}$  separated by  $\pi$  radians or half a wavelength of line. This characteristic is to be expected as it is in accordance with the well-known fact that the impedance of a transmission line passes through a complete cycle every half wavelength along the line. Hence, it is not possible to determine from one measurement the number of full half wavelength sections in the line. However, in calculating the impedance transformation between the bridge end of the line and the point in question as outlined in Paragraph 2.724, the multi-valued nature of the function is of no importance as the same answer is obtained for all the values of the function if the line is lossless.

The true value of  $\beta l$  can be determined from measurements of the input reactance at more than one frequency or from a comparison of the possible values and an estimate of the electrical length of the line. The approximate electrical length in centimeters is equal to the physical length divided by the velocity of propagation expressed as a fraction of the free space velocity. The relative velocity of propagation is equal to the reciprocal of the square root of the dielectric constant of the insulating material between the inner and outer conductors in the line.

**2.724 Calculation of the Impedance at the Far End of the Line under Test:** The impedance at the far end or any other point of the transmission line can be calculated from the effective measured impedance and the electrical length of the transmission line between the bridge and the point in question using standard transmission-line equations. This calculation can be carried out very simply using the Smith Chart<sup>5</sup> or other transmission line charts. The actual lossless transmission-line equation, which is rather awkward to use, is:

$$Z_2 = Z_0 \frac{Z_e - jZ_0 \tan \beta l}{Z_0 - jZ_e \tan \beta l} \quad (22)$$

where  $Z_e$  is the effective measured impedance,  $Z_0$  the characteristic impedance of the line, 50 ohms,  $Z_2$  is the impedance at the point in question, and  $\beta l$  is the electrical length of the line.

**2.725 Measurement of Coaxial Impedances Outside the Direct-Reading Range of the Bridge:** Coaxial-line impedances outside the range of the bridge can be mea-

sured using a short additional length of line between the bridge and the circuit under test as an impedance transformer. Short, rigid air lines such as the Type 874-L10 or L20 Air Lines or lengths of cable can be used for this transformation.

**2.726 Measurement of Coaxial Circuits Having Impedances other than 50 ohms:** Coaxial circuits having characteristic impedances other than approximately 50 ohms can be measured using the bridge terminals alone or the coaxial adaptor provided. If the bridge terminals alone are used, the outer conductor of the coaxial line under test should be bonded to the ground plate as close as possible to the edge of the hole in the ground plate through which the ungrounded terminal projects. The inner conductor should be extended to connect to the ungrounded bridge terminal. The short circuit for the initial balance can be made, by means of a copper strap, directly at the end of the coaxial line between the inner and outer conductors or at the actual bridge terminals using the screw cap supplied. (See Paragraph 2.712.)

If the 50-ohm coaxial adaptor is used and the line under test connected to it by means of an appropriate connector, the actual impedance seen looking into the unknown line can be calculated from the impedance measured by the bridge by correcting for the length of 50-ohm line between the bridge terminals and the beginning of the unknown line. Care must be taken in this measurement to minimize the discontinuity effects at the junction of the two lines.

## 2.8 ILLUSTRATIVE EXAMPLES

As a guide to the practical application of the material in Paragraph 2.7, several illustrative examples follow:

(a) **Measurement of a 6 $\mu$ f Capacitor at 110 Mc:** The unknown impedance in this case is a small mica capacitor of good power factor. At this frequency the inductive reactance of the capacitor leads is important and therefore the capacitor should be connected across the bridge terminals with as short leads as possible or with leads approximating those actually used with the capacitor in a circuit. A compromise between stray capacitance to ground and lead length can be obtained by connecting the capacitor to the ungrounded bridge terminal and to the ground plate at the mounting hole nearest the ungrounded terminal, using a 3/16 inch spacer on each terminal to space the capacitor slightly away from the ground plane.

The reactance, including the effect of the terminal capacitance, will be of the order of 200 ohms; therefore set the reactance dial near its maximum value, say 230 ohms, the L-C switch in the C position, short-circuit the terminals with the threaded cap, and set up the initial balance as described in Paragraph 2.6.

Then remove the short circuit, connect the capacitor, and rebalance the bridge using the resistance and reactance dial controls. Suppose the final dial readings are 2.7 and 15 ohms respectively. Before corrections

<sup>5</sup>Smith, Phillip H., *Transmission Line Calculator*, ELEC-TRONICS, 17, 1, (1944); 12, 29, (1939); chart in slide rule form available from the Emeloid Corporation, Arlington, New Jersey.

for residual parameters the measured resistance,  $R_e$ , and reactance,  $X_e$ , are:

$$R_e = 2.7 \Omega$$

$$X_e = \frac{15 - 230}{1.1} = \frac{-215}{1.1} = -195 \Omega$$

As can be seen from Figure 11, the correction for inductance in the resistance capacitor is negligible.

Although the error in reactance due to inductance in the reactance capacitor is small, it can be corrected for if desired by looking up the correction factor for 110 Mc in Figure 12. The corrected value of measured reactance,  $X_e'$ , is then:

$$X_e' = -195 \times 1.02 = -199 \Omega$$

If the resistance of the capacitor is of importance, it should be corrected for the effects of stray internal capacitances in the bridge circuit. To do this, look up in Figure 13 the resistance correction corresponding to the bridge reactance dial reading and frequency. The corrected value of the measured resistance,  $R_e'$ , is then:

$$R_e' = 3.1 - 215 \times .008 = 2.7 - 1.7 = 1.0 \Omega$$

The terminal capacitance will have an appreciable effect on the measurements in this application as its reactance is appreciable compared to that of the capacitor under test. Since the terminal capacitance under the conditions of measurement is  $1.1 \mu\mu f$ , the correction chart described in Paragraph 2.712 can be used directly. To use the chart take the difference in the reactance dial readings,  $X_d$ , and the product of the effective resistance and the frequency in hundreds of megacycles,  $fR_e$ , and find the corresponding point in the  $X_d - fR_e$  plane. Then read the coordinates of this point in the  $X_c - r$  plane. In this application,  $X_d = -215 \times 1.02 = -219$ ,  $fR_e = 1.1$  and the corresponding values of  $X_c$  and  $r$  are  $-39$  and  $1.39$  respectively. Therefore the actual resistance and reactance of the capacitor are:

$$R_x = 1.0 \times 1.39 = 1.39 \Omega$$

$$X_x = \frac{-219 - 39}{1.1} = -234 \Omega$$

$$C_{x_e} = 6.2 \mu\mu f$$

Equations (13) and (14) can be used for terminal capacitance instead of the chart. At 110 Mc, the reactance,  $X_a$ , of the  $1.1 \mu\mu f$  terminal capacitance is  $-1320$  ohms. Therefore:

$$R_x = \frac{1.0}{1 - \left(\frac{-199}{-1320}\right)^2 + \left(\frac{1}{1320}\right)^2} = 1.39 \text{ ohms}$$

$$X_x = \frac{-199 - \frac{(1.0)^2}{-1320} - \frac{(-199)^2}{-1320}}{1 - \left(\frac{-199}{-1320}\right)^2 + \left(\frac{1}{1320}\right)^2} = -234 \text{ ohms}$$

The effective capacitance,  $C_e$ , includes the effect of the series inductance,  $L$ , of the capacitor and its leads and is:

$$C_e = \frac{C_0}{1 - \omega^2 LC_0} \quad \text{or} \quad \frac{1}{C_e} = \frac{1}{C_0} - \omega^2 L \quad (21)$$

where  $C_0$  is the actual capacitance. The value of  $L$  and  $C_0$  can be determined by measuring the effective capacitance at one or more different frequencies, preferably one appreciably different. Equation (21) can be manipulated to give expressions for  $L$  and  $C_0$  or for greater accuracy  $\frac{1}{C_e}$  can be plotted against  $\omega^2$  and a straight line drawn through the points. The y axis intercept of the straight line is  $\frac{1}{C_0}$  and the slope of the line is equal to  $L$ .

(b) Measurement of a 100-ohm 1/2 Watt Carbon Resistor at 120 Mc: As in the last example, the leads and the position of the resistor with respect to the ground plane have a large effect on the measurements. The resistor should be mounted in a manner as similar as possible to that in which it is intended to be used. In the case under consideration let us assume that the resistor is to be mounted between two terminals 1-1/4 inches apart. The best approximation to this arrangement is similar to that used in Example (a).

In this case the reactance will be relatively low so for a guess let us set up the initial balance with the reactance dial set at about 5 and the L-C switch in the L position using the threaded cap for the short circuit as described in Paragraph 2.6. Suppose the actual reactance dial reading is 4.5. Then connect the resistor to the terminals and rebalance the bridge with the resistance and reactance dial controls. Suppose the resistance and reactance dial readings are 102 ohms and 3.5 ohms respectively. The measured resistance,  $R_e$ , and reactance,  $X_e$ , are then:

$$R_e = 102 \Omega$$

$$X_e = \frac{3.5 - 4.5}{1.2} = -.8 \Omega$$

To correct for inductance in the resistance capacitor look up the K factor in Figure 11 corresponding to the value of  $R_e$  and the frequency. In this case,  $K = 1.06$  .:

$$R_e = 102 \times 1.06 = 108 \Omega$$

The corrections for inductance in the reactance capacitor and stray internal bridge capacitances are negligible in this case.



To correct for the capacitance across the bridge terminals, use the chart in Figure 10. First multiply  $R_e$  by the frequency in hundreds of megacycles,  $dKMc$ ,  $108 \times 1.2 = 130$ , and find the actual reactance dial reading before division by the frequency,  $X_d = -1$ . Then find the point in the  $fR_e - X_d$  plane corresponding to these values and determine the coordinates of this point in the  $r - X_c$  plane which in this case are  $r = 1.02$  and  $X_c = +4$ . Therefore the true resistance and reactance of the resistor are

$$R_x = 108 \times .992 = 107.2 \Omega$$

$$X_x = \frac{-1 + 11.6}{1.2} = +8.8 \Omega$$

(c) Measurement of the Characteristic Impedance of Coaxial Transmission Lines: The characteristic impedance,  $Z_0$ , of a transmission line can be calculated from measurements of the input impedance of the line with the output short-circuited,  $Z_{sc}$ , and open-circuited,  $Z_{oc}$ .

$$Z_0 = \sqrt{Z_{oc}Z_{sc}} \quad (22)$$

The coaxial adaptor is convenient to use for measurements on cables whose characteristic impedance is approximately 50 ohms; however, in the general case, the bridge terminals can be used. (See Paragraph 2.726.) If properly carried out, the measurements are rather simple as the effects of terminal capacitance and lead inductance can be made negligible and therefore no corrections for these effects are required. To eliminate the effect of terminal capacitance plus lead capacitance, the line under test should have an electrical length of approximately one-eighth wavelength. For this length, the shorted and open reactances are equal in magnitude and opposite in sign. The fractional error resulting from deviations from the proper length is:

$\frac{X_{sc} - X_{oc}}{X_a}$  where  $X_{sc}$  and  $X_{oc}$  are the measured short- and open-circuit reactances, and  $X_a$  is the reactance of the terminal and lead capacitance. The above simplification is accurate within 1% if  $\frac{Z_0}{X_a} < 0.1$  and  $\frac{X_L}{X_a} < 0.01$ , where  $X_L$  is the inductance of the lead connecting the bridge terminals with the line. Of course, the measurement can be made on any length of cable, if corrections are made for the effects of terminal capacitance and lead inductance.

In a measurement of this type the outer conductor of the line should be fastened to the ground plate as described in Paragraph 2.726 and the short-circuit for the initial balance made directly at the input to the line under test by means of a low-inductance strap. The inductance of the connecting lead can be estimated easily or can be measured by first setting up an initial balance using the screw cap and then measuring the reactance the bridge sees with the line under test connected but with its input short-circuited. Under these conditions the terminal capacitance is about  $1.1 \mu\mu f$  and the lead capacitance usually can be estimated sufficiently accurately.

Suppose the measurement were to be made on a cable having about a 72-ohm characteristic impedance at a frequency of 50 megacycles. At this frequency, the reactance of the lead from the line to the bridge terminals is about 4 ohms, assuming a lead length of 2 cm. The total capacitance of the terminal and lead may be about  $2 \mu\mu f$  which produces a reactance of about 1600 ohms at 50 Mc. Therefore,  $\frac{Z_0}{X_a} \approx .05$  and  $\frac{X_L}{X_a} \approx .0025$  which are well within the limits previously specified for the use of the simplified method of measurement.

For the measurement of the reactance with the line short-circuited, set up the initial balance with the short circuit made directly at the input to the line and the reactance dial set as close to zero as desired, say it is found to be 0.4 ohm in this case. Remove the short circuit and rebalance the bridge. Suppose the dial now reads 37.2 ohms. The measured reactance is therefore:

$$X_{sc} = \frac{37.2 - 0.4}{0.5} = +73.6 \Omega$$

Next, open-circuit the cable at its far end (the far ends should not have the center conductor protruding from the end of the cable or an appreciable error may result from the capacitance of the extended conductor), set up the initial balance again with the reactance dial set at about 40 ohms; suppose it reads 39.3. Then remove the short circuit and rebalance the bridge. The reactance dial now reads 4.1 ohms. The measured reactance is therefore:

$$X_{oc} = \frac{4.1 - 39.3}{.5} = -70.4 \Omega$$

The characteristic impedance of the cable is then:

$$Z_0 = \sqrt{X_{sc}X_{oc}} = 72.0 \Omega$$

If the terminal and lead reactances had been greater than the limits specified, more exact results could have been obtained by actually correcting for the residual parameters as previously outlined. Also the example treated a line in which the losses were negligible and the measured resistance was very small compared to the measured reactance. If the losses are not negligible, the actual value of the characteristic impedance can be calculated using Equation (22) in its complex form.

(d) Measurement of the Attenuation of Cables: The attenuation of a cable of any known characteristic impedance can be determined easily from impedance measurements by measuring the input resistance when the line is electrically an odd number of quarter-wavelengths long and open-circuited, or an even number of quarter-wavelengths long and short-circuited. Under these conditions the input impedance will be a pure resistance having a magnitude

$$R_i = Z_0 \tanh \alpha l \quad (23)$$





where  $\alpha$  is the attenuation constant in nepers per cm and  $\ell$  is the length of the line in cm. The expressions for the attenuation of the line are:

$$\alpha = \frac{1}{\ell} \tanh^{-1} \frac{R_i}{Z_0} \text{ nepers/cm} \quad (24a)$$

$$= \frac{2.651 \times 10^4}{\ell} \tanh^{-1} \frac{R_i}{Z_0} \text{ db/100 ft.} \quad (24b)$$

Cable having a 50-ohm characteristic impedance can be measured using the coaxial adaptor or in the general case the cable can be connected to the bridge as in Example (c). With the coaxial adaptor, the initial balance can be set up using the screw cap or the coaxial short circuit. For the terminals, the short circuit can be made most conveniently directly at the input to the line unless the contact resistance of the short circuit is found to be appreciable. In this case the short circuit can be set up in the normal manner using the screw cap and the measurements corrected for the reactance of the connecting lead.

In either case a piece of line long enough to produce an attenuation which results in a readable resistance on the resistance dial should be used. The first measurement will probably show that the reactance is not zero. The procedure is to change the physical length of the line or the frequency until resonance is achieved. The length of an open-circuited line can be changed very easily by clipping pieces off its end. Suppose at 100 Mc, the resistance of an eight foot length of 50-ohm open-circuited cable 88.6 feet long (2250 cm) is 4.8 ohms. Therefore

$$\alpha = \frac{1}{2250} \tanh^{-1} \frac{4.8}{50} = 0.427 \times 10^{-4} \text{ nepers/cm}$$

$$= 1.13 \text{ db/100 ft.}$$

If the screw cap is used for the short circuit in the terminal case or the coaxial short circuit in the coaxial case, the algebraic sum of the reactance of the short-circuited lead or adaptor and the measured reactance must be equal to zero.

The velocity of propagation in the cable relative to that in free space can be determined from the measurements outlined above if the actual number of quarter wavelengths of electrical length in the line is determined.

$$\text{relative velocity} = \frac{4\ell}{n\lambda}$$

where  $\lambda$  is the free space wavelength, in cm, and  $n$  is an integer equal to the number of quarter wavelengths in the line under test. In the above example,  $n = 20$ , therefore:

$$\text{relative velocity} = \frac{4 \times 2250}{20 \times 600} = 0.667$$

(e) Measurement of the Electrical Length of a Section of Transmission Line: The electrical length of a section of transmission line can be calculated if its characteristic impedance is known from its input reactance with its output open or short-circuited as described in Paragraph 2.723.

$$\beta \ell = \tan^{-1} \frac{X_{sc}}{Z_0} \text{ radians (short circuit)}$$

$$\beta \ell = \cot^{-1} \frac{X_{oc}}{Z_0} \text{ radians (open circuit)}$$

In the case of a 50-ohm cable, the reactance can be measured using the coaxial adaptor. Suppose that the electrical length of a 3-foot length of cable is desired at a frequency of 100 Mc. It is assumed that the bridge end of the cable is terminated in a Type 874 Connector or another type of connector with a suitable adaptor. Short-circuit the adaptor with the coaxial short circuit and set up the initial balance with the reactance dial near 50; suppose it turns out to be 51.1 ohms. Remove the short circuit and plug in the cable under test with its far end short-circuited with as low inductance of a short circuit as possible. Rebalance the bridge with the resistance and reactance dial controls. Suppose the final reactance dial reading is 4.3 ohms. The measured reactance is then

$$X_e = \frac{4.3 - 51.1}{1.0} = -46.8 \Omega$$

To correct for the initial balance reactance of the adaptor line, look up its reactance at 100 Mc in Figure 14 where it is found to be +5.4 ohms. The effective reactance the bridge sees is then

$$X_e' = -46.8 + 5.4 = -41.4 \Omega$$

The total electrical length of the line including the adaptor is therefore

$$\beta \ell = \tan^{-1} \left( \frac{-41.4}{50} \right) = \tan^{-1} (-0.828) = 140.4^\circ \text{ or } 0.390 \text{ wavelength}$$

As discussed in Paragraph 2.723, the length may be an integer number of half-wavelengths greater than the value obtained above.

If the actual length of the line under test alone is desired, it can be found by subtracting the electrical length of the adaptor from the above results. However, in cases in which the impedance at a point along the line is to be determined from the impedance measured by the bridge and a knowledge of the electrical length of line between the two points, the electrical length of the coaxial adaptor should be included if it is used. The velocity of propagation in the line can be calculated from the above data by taking the ratio of product of the measured electrical length and the free space wavelengths to the actual physical length of the line under test.



(f) Measurement of the Impedance of an Antenna Fed by a 50-ohm Coaxial Cable: Antenna impedances can be measured in the same manner as described previously. The bridge actually measures the impedance at the bridge end of the cable and indirectly the electrical length of the line. With this information the impedance at any point along the cable including the impedance at the antenna itself can be determined by using one of various transmission line charts such as the Smith Chart (see Paragraph 2.724) or standard transmission-line equations. In the measurement of antennas care must be taken to see that no significant amount of leakage occurs between the generator and the antenna or between the antenna and the receiver. This can be checked as outlined in Paragraph 2.4.

Suppose in this case an antenna is to be measured at a frequency of 90 megacycles. If the length of the connecting cable is unimportant, use as short a length as is consistent with convenience and negligible leakage. First short-circuit the coaxial adaptor with the short-circuiting plug (see Paragraph 2.72 for another method of short-circuiting) and set up the initial balance as described in Paragraph 2.6 with the L-C switch in the L position and the reactance dial at about 80 as neither the sign nor magnitude of the unknown reactance is known. Suppose the actual reading obtained is 79 ohms. Remove the short circuit and connect the cable from the antenna. Then rebalance the bridge, using the resistance and reactance dial controls. Suppose the final resistance and reactance dial readings are 33.1 and 71.5 ohms respectively. In this case the resistance reading is adequate, but greater accuracy in the reactance reading could be obtained by setting the initial balance closer to zero. Therefore if greater accuracy is desired reset the initial balance at about 10, which is shifted to 9.8 to make the fine initial reactance balance, and repeat the measurement. Suppose the resistance and reactance dial readings obtained in this case are 33.1 and 1.4 ohms respectively. The measured impedance is then

$$R_e = 33.1 \Omega$$

$$X_e = \frac{1.4 - 9.8}{.9} = -9.3 \Omega$$

To correct for the effect of inductance in the resistance capacitor find the K factor corresponding to the frequency and resistance in Figure 11. It is K = 1.02. The effective resistance is therefore

$$R_e' = 33.1 \times 1.02 = 33.8 \Omega$$

The correction for inductance in the reactance capacitor is negligible; however, the reactance of the short circuit must be added to the measured reactance. From Figure 14 the reactance is found to be +5.0 ohms. Therefore the effective reactance is:

$$X_e' = -9.3 + 5.0 = -4.3 \Omega$$

The voltage standing wave ratio on the line can be calculated from the effective resistance and react-

ance using Equation (20).

$$VSWR = \frac{1 + \frac{|50 - 33.8 + j4.3|}{|50 + 33.8 - j4.3|}}{1 - \frac{|50 - 33.8 + j4.3|}{|50 + 33.8 - j4.3|}} = \frac{1 + .201}{1 - .201} = 1.50$$

The impedance at the antenna can be determined by first measuring the electrical length of the line between the bridge and the antenna as outlined in Paragraph 2.723 and Example (2). In this case the antenna end of the line should be short-circuited with as low an inductance connection as possible. Suppose the electrical length of the line including the adaptor is 0.44 wavelength. The information required to use the Smith Chart is:

$$\frac{R}{Z_0} = \frac{33.8}{50} = .676$$

$$\frac{X}{Z_0} = \frac{-4.3}{50} = -.086$$

$$\ell = 0.44 \lambda$$

where  $\ell$  is the electrical length of the line in wavelengths between the two points in question. From the chart it is found that the impedance at the load end of the line is:

$$\frac{R_x}{Z_0} = 0.68, \quad R_x = 34.0$$

$$\frac{X_x}{Z_0} = 0.12, \quad X_x = +6.0$$

Of course, the VSWR is the same at this point as at the bridge terminals as it is independent of position along a lossless line. The VSWR also can be obtained directly from the Smith Chart. In this case it appears to be 1.50.

If the measured impedance is outside the range of the bridge an additional short section of line can be used as an impedance transformer as described in Paragraph 2.725.

## 2.9 BALANCED LINES AND ANTENNAS

The measurement of three-terminal devices, such as balanced lines and antennas, can be made with the bridge, although the computations involved are quite laborious.

The method depends upon the analysis of the unknown impedance in terms of the equivalent circuit of Figure 15 and requires three separate measurements, as follows:

- (1) Short-circuit impedance  $Z_1$  by grounding line A at point of measurement, and measure impedance  $Z'$  from line B to ground.

$$Z^1 = \frac{Z_2 Z_3}{Z_2 + Z_3} \quad (26)$$

(2) Short-circuit impedance  $Z_2$  by connecting line A to line B at point of measurement, and measure impedance  $Z^n$  from the junction to ground.

$$Z^n = \frac{Z_3 Z_1}{Z_3 + Z_1} \quad (27)$$

(3) Short-circuit impedance  $Z_3$  by grounding line B at point of measurement, and measure impedance  $Z^m$  from line A to ground.

$$Z^m = \frac{Z_1 Z_2}{Z_1 + Z_2} \quad (28)$$

Combining Equations (26), (27), and (28) gives:

$$Z_1 = \frac{2Z^1 Z^n Z^m}{Z^1 Z^n - Z^n Z^m + Z^m Z^1} \quad (29)$$

$$= \frac{2}{-\frac{1}{Z^1} + \frac{1}{Z^n} + \frac{1}{Z^m}}$$

$$Z_2 = \frac{2Z^1 Z^n Z^m}{Z^1 Z^n + Z^n Z^m - Z^m Z^1} \quad (30)$$

$$= \frac{2}{\frac{1}{Z^1} - \frac{1}{Z^n} + \frac{1}{Z^m}}$$

$$Z_3 = \frac{2Z^1 Z^n Z^m}{-Z^1 Z^n + Z^n Z^m + Z^m Z^1} \quad (31)$$

$$= \frac{2}{\frac{1}{Z^1} + \frac{1}{Z^n} - \frac{1}{Z^m}}$$

This method gives each component of impedance, detecting any unbalance. At perfect balance,  $Z_1 = Z_3$ ,  $Z^1 = Z^m$ .

$$Z_1 = Z_3 = 2Z^n \quad (29a)$$

$$Z_2 = \frac{2Z^1 Z^n}{2Z^n - Z^1} = \frac{1}{\frac{1}{Z^1} - \frac{1}{2Z^n}} \quad (30a)$$

When the balanced line is fed from a balanced source, the effective input impedance is given by:

$$Z_{AB} = \frac{2Z_1 Z_2}{2Z_1 + Z_2} = \frac{4Z^1 Z^n}{4Z^n - Z^1} \quad (32)$$

$Z_{AB}$  is the input impedance seen from the source. It should be measured once with the far end of the line open and once with it closed if it is desired to compute the characteristic impedance and propagation constant by the usual method. No grounds should be made to the line at any point other than the input when making measurements.

In Equations (26) to (32) the component impedances must, of course, be written in their complex forms.

### SECTION 3.0 CHECKS AND ADJUSTMENTS

#### 3.1 RESISTANCE CALIBRATION

If the calibration of the resistance dial changes slightly with time or rough usage, it can be restored by adjusting the trimmer capacitor,  $C_N'$  (see Figure 2). The screw projecting from the panel underneath the dial cover to the right of the initial resistance balance control adjusts the trimmer. A clockwise rotation of the screw increases the resistance dial reading and vice versa. The locking nut at the panel should be tightened securely after each adjustment.

To check the calibration, measure at 10 Mc the resistance of a good radio-frequency resistor such as an Allen Bradley Type GB-1/2 or the Type 874-WM Termination Unit. The resistor should be mounted across the bridge terminals with as short leads as possible. In either case the measured resistance should check the d-c value within 1%. If it does not, adjust  $C_N'$  until it does.

#### 3.2 CORRECTION FOR INDUCTANCE OF RESISTANCE CAPACITOR

The correction for inductance in the resistance capacitor can be checked at the 50-ohm level at any frequency by measuring the resistance of the Type 874-WM Termination Unit. The ratio of its d-c resistance to the measured resistance is the K factor found in Figure 11.

#### 3.3 REACTANCE OF STANDARD RESISTOR, $R_B$

The standard resistor,  $R_B$ , is adjusted at the factory to have practically zero reactance. If its reactance is not zero, the measured reactance of a circuit will be in error by an amount proportional to the measured resistance and the reactance in the standard resistor. If necessary, the reactance of the standard resistor can be adjusted by means of the screw located on the inside wall of the shield around C-6. This screw is accessible, when the bridge is removed from its case,



through holes in the shields surrounding C-6. The hole in the outermost shield is located on the side of the shield normally facing the side of the case on which the handle is mounted and is covered by a 1/2 inch snap button.

The reactance of the standard resistor can be checked by measuring the reactance of the Type 874-WM Termination Unit at 100 Mc. In this case the short-circuit for the initial balance should be made using the threaded cap, and the coaxial adaptor mounted after the initial balance has been made. In this case the measured reactance should be  $0 \pm 0.3$  ohms. To make the bridge reading more capacitive, rotate the screw clockwise and vice versa. The reactance may change rapidly with rotation. The locking nut on the adjusting screw should be tightened after each adjustment.

### 3.4 CORRECTION FOR STRAY INTERNAL CAPACITANCE IN THE BRIDGE CIRCUIT

The correction described in Paragraph 2.713 is subject to some variation among different instruments. The curves of Figure 13 may not be sufficiently accurate for most refined work. An independent check of this

effect at any frequency can be made by measuring the resistance and reactance of a very low-loss capacitor formed by connecting a small sheet of metal to the ungrounded terminal with the 3/16 inch spacer supplied inserted between the sheet and the terminal. The capacitance from this sheet to the ground plate forms a low-loss capacitor whose capacitance can be varied by varying the spacing between the sheet and the ground plate.

### 3.5 REMOVAL OF THE BRIDGE FROM CASE

To remove the bridge from its case, the six thumb screws located around the edge of the panel and the six 6-32 screws fastening the ground plate to the top of the instrument should be removed. Before removing the screws in the ground plate, tighten the two thumb screws on the ground plate to hold the plate in place when the 6-32 screws are removed. The hole in the ground plate, through which the ungrounded bridge terminal appears, must be concentric with the terminal or it will be difficult to mount the coaxial adaptor. If the ground plate is moved, it must be realigned to be concentric.

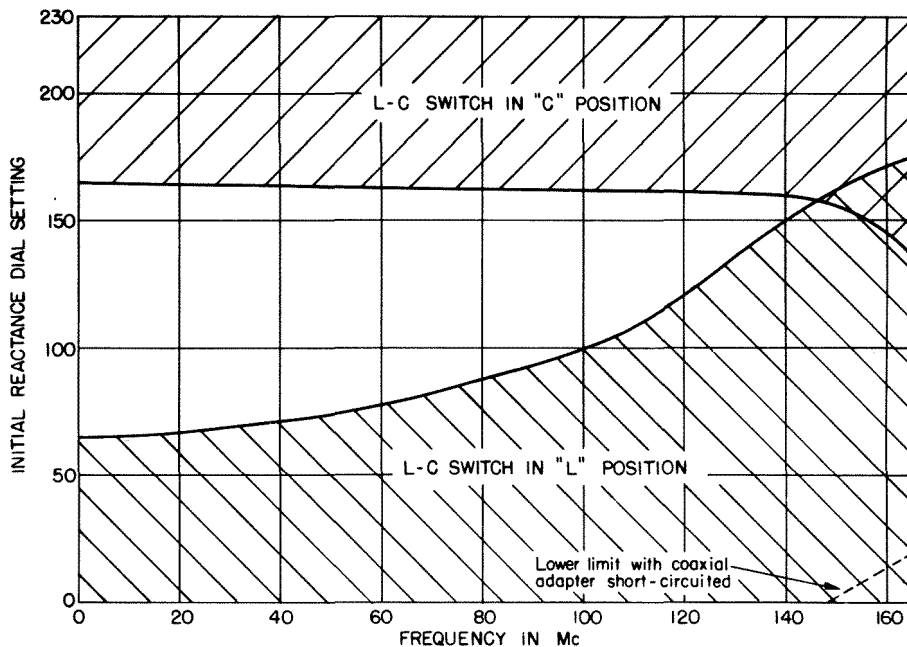

Figure 8. Range of Initial Reactance Dial Setting as a Function of Frequency.

TYPE 1601-A V-H-F BRIDGE

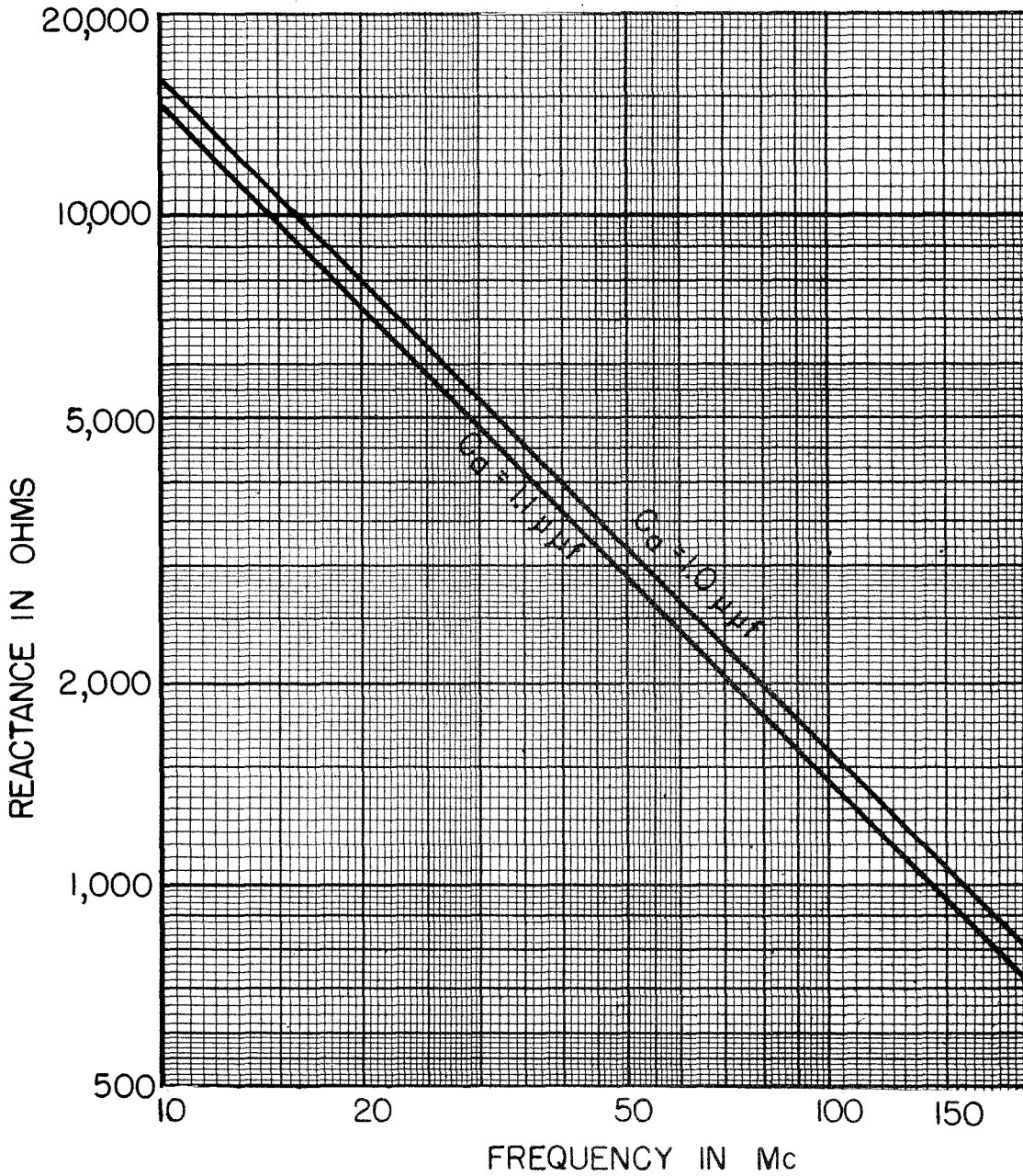

Figure 9. Reactance of Terminal Capacitance as a Function of Frequency.

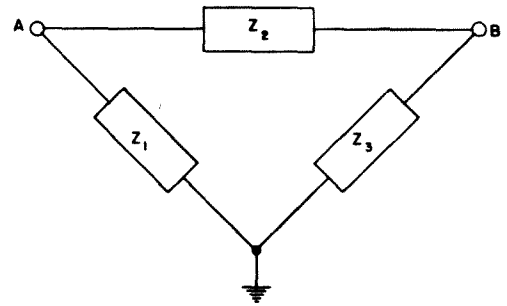
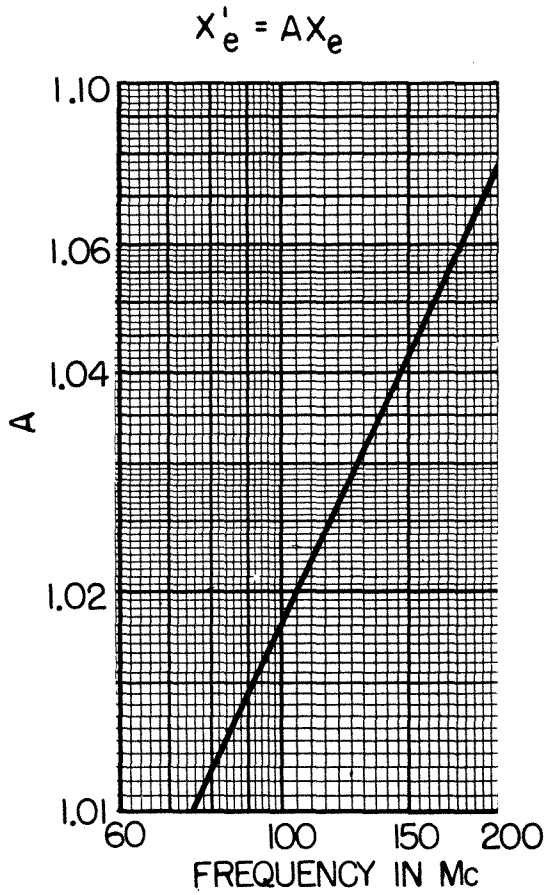

Figure 15. Equivalent Circuit of a Balanced Line.

Figure 12. Correction Chart for Inductance in Reactance Capacitor.

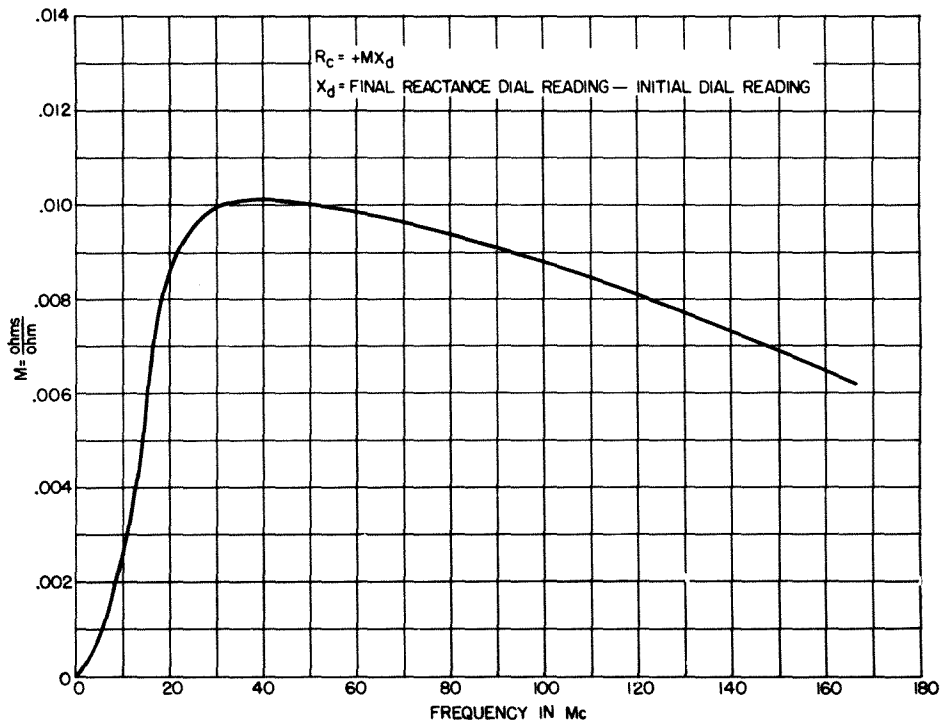

Figure 13. Resistance Correction due to Stray Capacitance Effects.

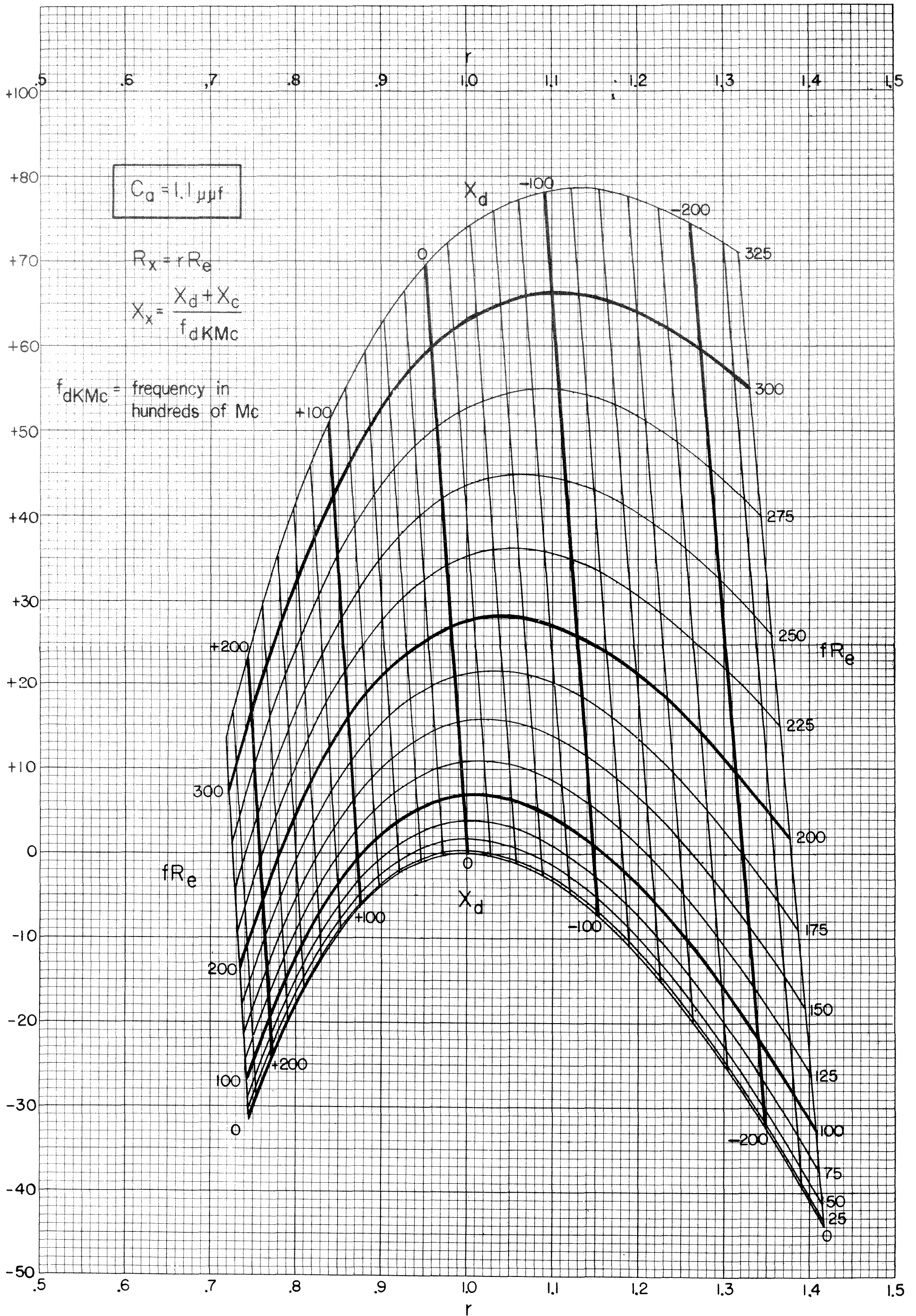

Figure 10. Correction Chart for Terminal Capacitance.

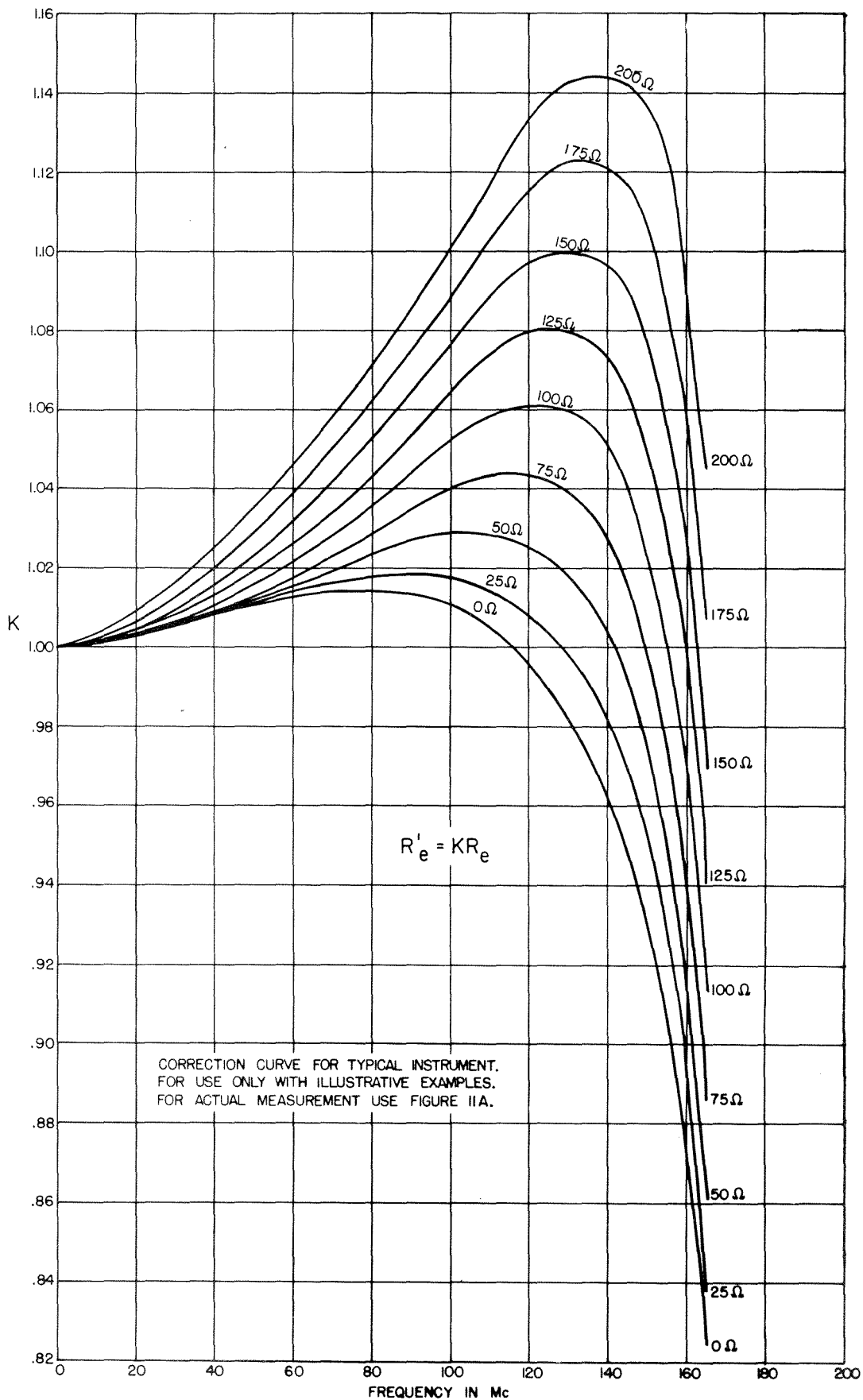

Figure 11. Correction Chart for Inductance in Resistance Capacitor.





TYPE 1601-A V-H-F BRIDGE

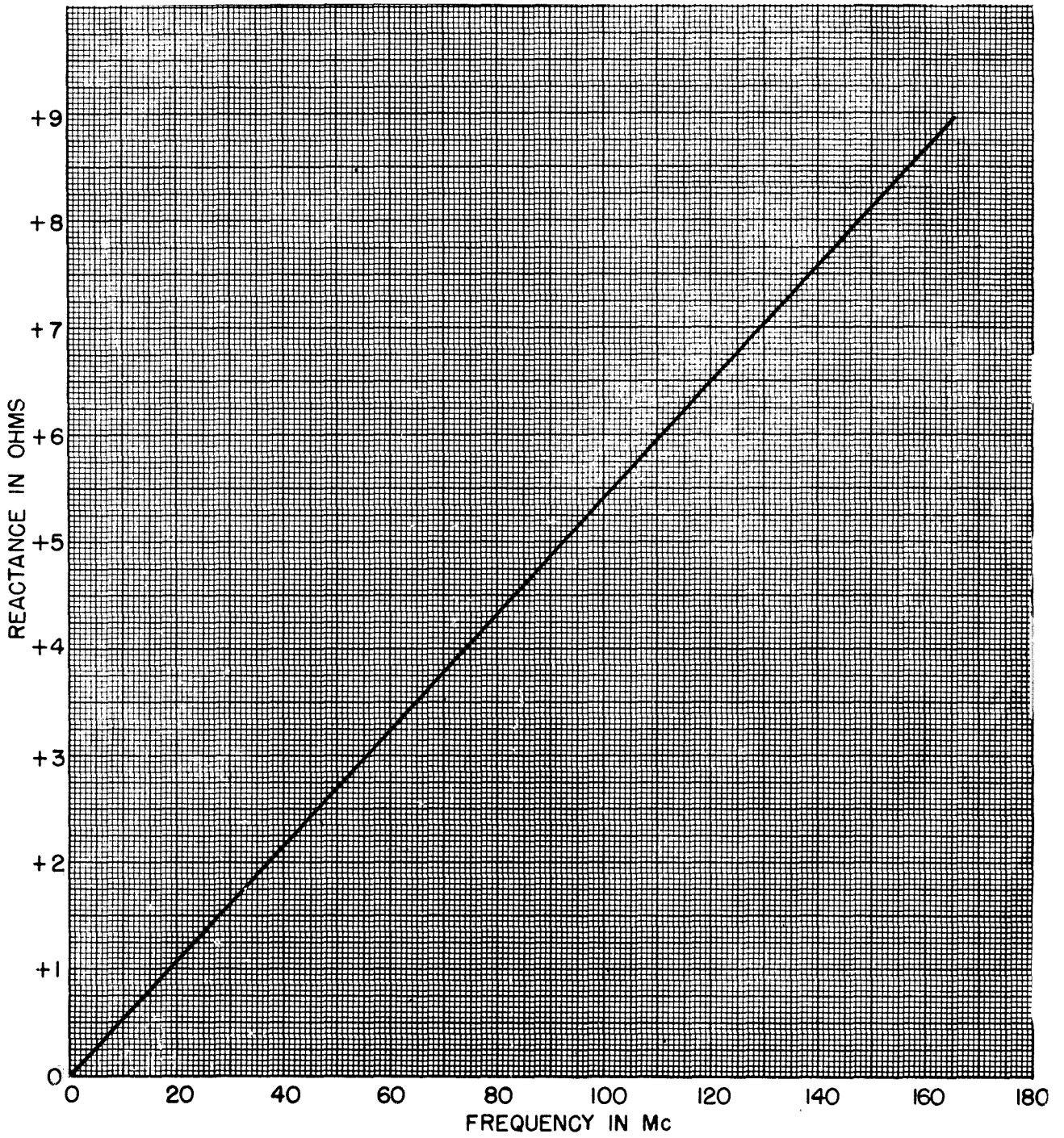
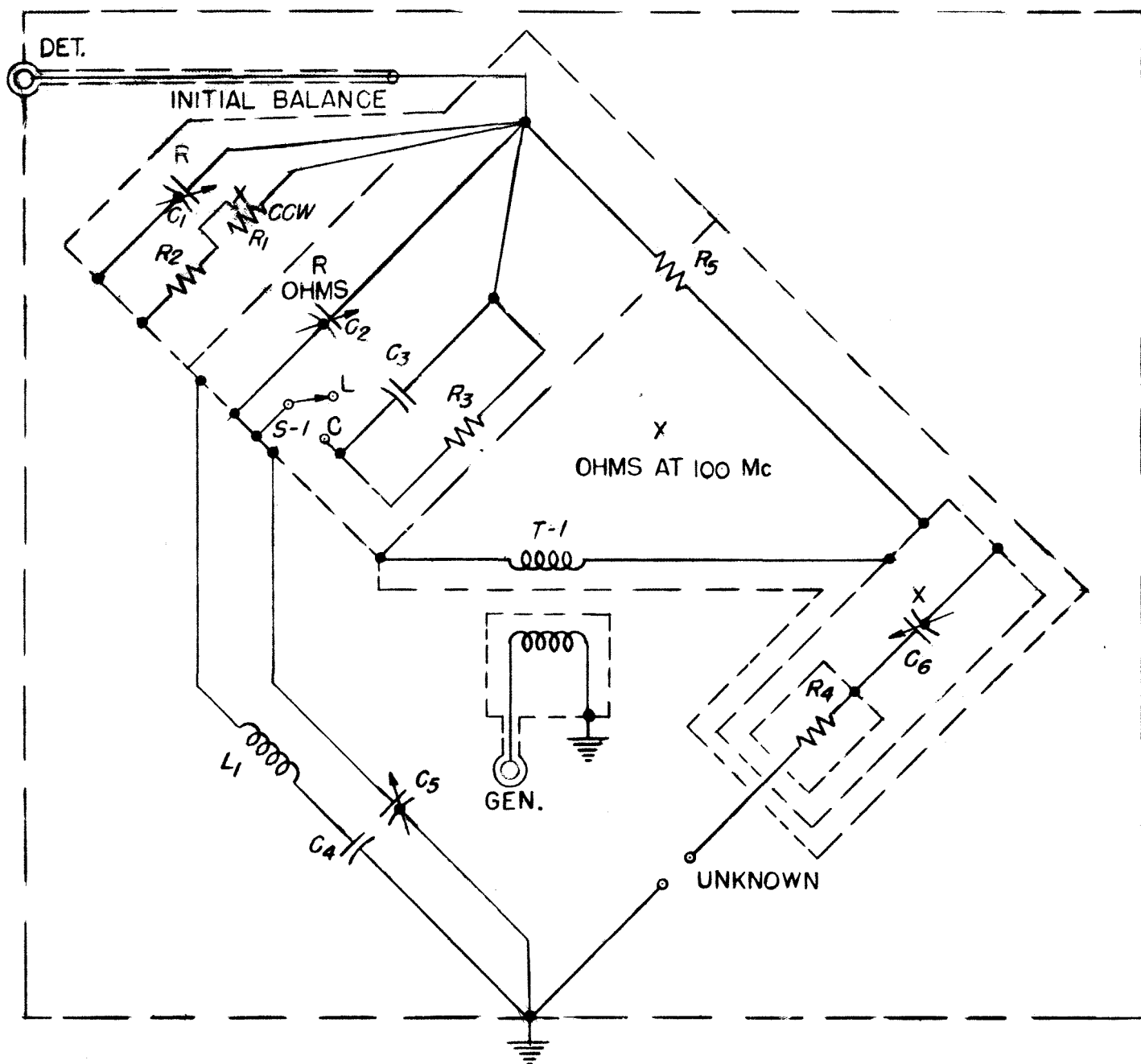

Figure 14. Reactance of Coaxial Adaptor versus Frequency.



Complete Wiring Diagram of Type 1601-A V-H-F Bridge.

RESISTORS		TYPE		CONDENSERS			
R1 =	1000 Ohms ±10%	GR	POSC-15	C1 =	2-12 μf	GR	846-403
R2 =	100 Ohms ±10%	AB	EB-1011	C2 =	35 μf var.	GR	847-405
R3 =	51 Ohms ±5%	AB	EB-5105	C3 =	8 μf ± 1 μf	EI. React. Corp.	NPO-CNL
R4 =	180 Ohms ±5%	AB	EB-1815	C4 =	6 μf ± 5%	(Built in)	
R5 =	250 Ohms ±1%	GR	1601-209	C5 =	0.5-5 μf	(Built in)	
				C6 =	50 μf var.	GR	846-401
MISCELLANEOUS				INDUCTORS			
S1 =	S.P.S.T.	GR (Built in)	1601-302				
T1 =	Input Trans.	GR	{ Pri Assem 1601-300 Sec Assem 1601-301	L1 =	0.085 μh	GR	1601-83