

**OPERATING AND MAINTENANCE
INSTRUCTIONS**

for

**TYPE 760-B
SOUND ANALYZER**



GENERAL RADIO COMPANY

CAMBRIDGE 39

MASSACHUSETTS

NEW YORK

CHICAGO

LOS ANGELES

U. S. A.

OPERATING AND MAINTENANCE
INSTRUCTIONS
for
TYPE 760-B
SOUND ANALYZER

Form 695-D
January, 1953



GENERAL RADIO COMPANY
CAMBRIDGE 39 MASSACHUSETTS
NEW YORK CHICAGO LOS ANGELES
U. S. A.



View of Type 760-B Sound Analyzer with Cover Removed.

Specifications

Frequency Range: Calibrated directly in cycles per second from 25 to 7500. This total range is covered in five complete turns of the tuning knob, the ranges on the various dial rotations being 25 to 75, 75, to 250, 250 to 750, 750 to 2500, and 2500 to 7500 cycles. A push-button switch allows immediate change of the main control to any one of these ranges.

Frequency Calibration: The accuracy of frequency calibration is $\pm 1-1/2\%$ of the frequency to which the dial is set or $\pm 1-1/2$ cycles per second, whichever is the larger.

Voltage Range: The analyzer will give usable indications on input voltages ranging from 1 millivolt to 10 volts. The meter scale is calibrated for reading directly component tones down to 1% of the sound pressure (or voltage) of the fundamental or loudest component. Accordingly, to make full use of this feature, the input voltage at the loudest component or fundamental should be 0.1 volt or higher.

Input Impedance: The input impedance is between 20,000 and 30,000 ohms, depending upon the setting of the sensitivity control. A blocking capacitor is in series with the input.

Frequency Response: The response is flat within ± 2 db over the entire range. At points where two ranges overlap, the sensitivity is the same on either range, within ± 1 db.

Band Width: The average selectivity is such that the relative attenuation is 3 db at 1% off the peak to which the analyzer is tuned.

Temperature and Humidity Effects: Under very severe conditions of temperature and humidity only slight, and generally negligible, shifts in calibration, sensitivity, and band width will occur.

Meter: The indicating meter is calibrated in two ranges. The nominal ranges are 0 to -30 db and -14 to -40 db. For convenience in use the meter scale is calibrated with the nominal range located 2 db below full scale on the meter, so that actual meter scales are +2 to -30 db and -12 to -40 db. Auxiliary percentage ranges of 0 to 120% and 0 to 24% are provided.

Headphones: A jack is provided on the panel for plugging in a pair of head telephones, in order to listen to the actual component of the sound to which the instrument is tuned. This is also useful when the analyzer is used as a bridge-balance indicator.

Tubes: Three 1L4 and one 1U4 tubes are used together with a neon pilot light (NE-51). All are supplied.

Specifications continued

Batteries: The batteries required are four Burgess No. 2FBP 1.5-volt batteries, or the equivalent, and three Burgess No. Z30NX 45-volt batteries, or the equivalent. A compartment is provided in the case of the analyzer for holding all batteries, and connections are automatically made to the batteries when the cover of this compartment is closed. A set of batteries is included in the price of the instrument.

Accessories Supplied: A shielded cable-and-plug assembly for connecting the analyzer to the sound-level meter.

Case: The analyzer is built into a shielded carrying case of airplane-luggage construction.

Dimensions: (Length) 18 x (width) 10 x (height) 11-1/2 inches, overall.

Net Weight: 36-1/2 pounds, with batteries; 29-3/4 pounds, without batteries.

U.S. Patent No. 2,173,426

Printed
in
U.S.A.

OPERATING INSTRUCTIONS

for

TYPE 760-B SOUND ANALYZER

PART I INTRODUCTION

The Type 760-B Sound Analyzer is intended primarily for use with the Type 1551-A or Type 759-B Sound-Level Meter to separate complex sounds and noises into their various frequency components. It is also useful as a general-purpose laboratory harmonic analyzer, and can be used as a frequency-selective bridge detector for audio frequencies.

The band width of the analyzer is a constant percentage of the frequency to which the analyzer is tuned.

PART II DESCRIPTION

The principle upon which the analyzer operates is shown in the functional block diagram of Figure 1. The essential elements are an input control, a

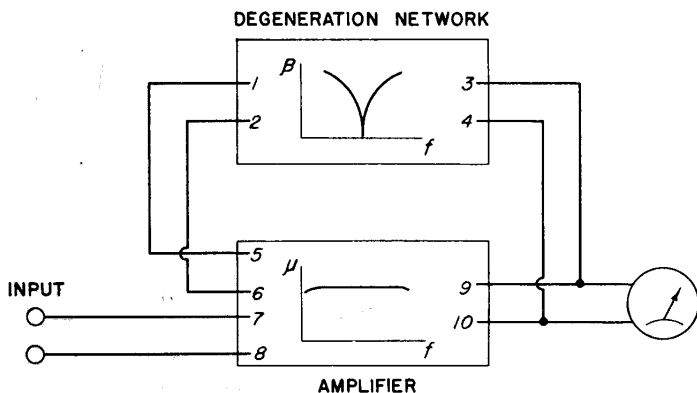

Figure 1. Functional Block Diagram of Type 760-B Sound Analyzer.

GENERAL RADIO COMPANY

wide-range amplifier with high gain, a feed-back network, and an output voltmeter. The feedback is frequency selective and is negative at all frequencies except that to which the circuit is tuned. The resultant selectivity curve of the complete analyzer is shown in Figure 2.

Figure 3* and Figure 4** are, respectively, a simplified schematic and a complete wiring diagram. As is shown in Figure 3, the feed-back network is a parallel-T network with its variable arms ganged for operation from a single control.

Reference to Figure 4 shows how the complete frequency range of 25 to 7500 cycles is covered. The variable resistors and a single set of capacitors span the highest range of 3:1 in frequency (2500-7500 cycles), and additional capacitors are added for successively lower ranges.

The output voltmeter has two ranges (+2 to -30 db and -12 to -40 db) in order that frequency components varying in amplitude over a range exceeding 40 db may be read. Two scales are provided, one reading in decibels and the other in percentage of full scale.

*See Page 10.

**See Page 11.

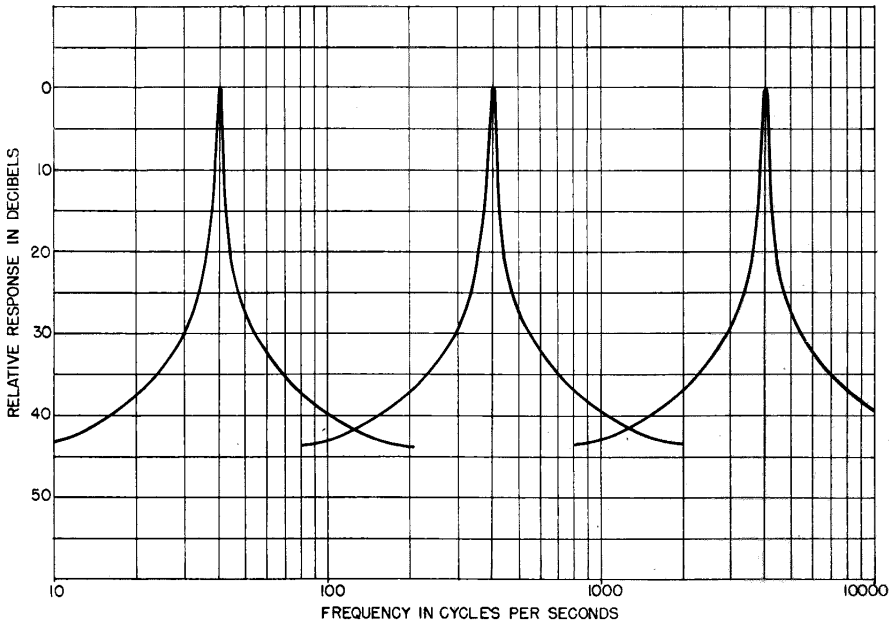

Figure 2. Selectivity Curve Plot for Frequencies of 25, 400, and 6000 Cycles. Note that the bandwidth is a constant percentage of the operating frequency.

TYPE 760-B SOUND ANALYZER

PART III

OPERATION

3.1 BATTERIES

Place in battery box exactly as shown in Figure 5. All types shown are of Burgess manufacture. Remove Bakelite binding post tops except on center terminals of Z30NX batteries.

Placing the cover on the battery box automatically makes all necessary connections. Be sure that the plug on the battery cable is connected to the bypass capacitor block in the bottom of the cabinet.

The push buttons marked BATTERIES check the battery voltages. Replace batteries when the deflection is below the red line at B.

3.2 TUBES

V-1 to V-3, inclusive: Type 1L4; V-4: Type 1U4. For location, see Figure 6.

The pilot lamp on the panel (V-5) is a G.E. NE 51 or equivalent.

3.3 TUNING

The analyzer is tuned by means of the large knob and the row of push buttons beneath it. The buttons select the particular frequency range and the knob provides tuning over that range. The calibration is direct reading in cycles per second and can be converted to rpm by multiplying by 60.

3.4 SOUND ANALYSIS - RELATIVE READINGS

To analyze a sound, connect the input of the analyzer to the output of the Type 1551-A or Type 759-B Sound-Level Meter by means of the cord provided. Both instruments should be turned on. The level of the sound which strikes

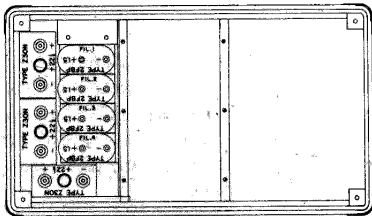

Figure 5. Location of Batteries.

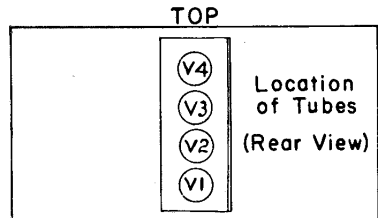

Figure 6. Location of Tubes.

GENERAL RADIO COMPANY

the microphone will be indicated directly on the meter on the panel of the sound-level meter. This reading is the total sound pressure. Press Button A on the sound analyzer, which selects the 25- to 75-cycle range, and turn the main dial slowly from 25 to 75 cycles, noting the deflections of the meter on the sound analyzer. Repeat this process, covering the entire range of the instrument by successively depressing Buttons B, C, D, and E and turning the dial around. The instrument is so constructed that the dial can be rotated continuously in one direction, thus facilitating rapid scanning of the entire frequency range.

During this process the sensitivity control of the analyzer should be turned down whenever a component is found which deflects the meter above the 0 db (100%) point, so that the meter reads exactly at this point. This sets the sensitivity so that the analyzer will read 0 db on the loudest component in the sound. Do not change the setting of this control before the analysis is completed. The analyzer should then be carefully tuned for maximum amplitude on each component (without touching the sensitivity control) and the results recorded. This provides an analysis directly in terms of the loudest component, which is generally, but not always, the fundamental.

An approximate setting of the sensitivity control can be quickly determined by releasing all of the tuning buttons. The tuning buttons can easily be released by partially depressing any button which is not already depressed. This removes the frequency selective feed-back circuit so that the meter can be set to read 0 db for the total sound-pressure before analysis is commenced.

The sensitivity control on the analyzer is intended only for use in making the initial setting and it need not be used as a multiplier for the meter or to extend the scale of the meter. Maximum attenuation outside the pass band does not permit accurate determination of components having amplitudes much more than 40 db below the fundamental or loudest component.

3.5 SOUND ANALYSIS - ABSOLUTE READINGS

Relative readings are generally sufficient for practical analyses, but if it is desired to have the readings in terms of the absolute sound level rather than referred to the strongest component, proceed as follows:

Calibrate the sound-level meter using the a-c power line as outlined in the Operating Instructions. This will provide a deflection on the indicating meter of approximately +3 db.

Connect the analyzer to the sound-level meter, tune the analyzer to the power-line frequency and adjust the SENSITIVITY control so that the indicating meter on the analyzer reads 10 db lower than that on the sound-level meter. For instance, if the sound meter reads +3 db the analyzer meter should read -7 db. Do not further readjust the SENSITIVITY control. The dial can be marked with pencil to show the proper setting, if desired.

Disconnect the sound-level meter from the power line and adjust the DECIBELS control of the sound-level meter for normal measurement of the

TYPE 760-B SOUND ANALYZER

sound with the indicating meter showing a deflection between 0 and 10 (except, of course, for levels below 30 db). The analyzer may then be tuned to each individual component in the normal manner. Do not change the setting of the sensitivity control on the analyzer. The absolute level of each component will be indicated directly by the algebraic sum of the setting of the DECIBELS switch on the sound-level meter and the decibels reading of the indicating meter on the analyzer, plus 10 db. The DECIBELS switch on the sound-level meter should not be used to increase the deflection of the meter on the analyzer on low-amplitude components since this would overload the output circuits of the sound-level meter and cause distortion.

3.6 CHOICE OF WEIGHTING NETWORK ON SOUND-LEVEL METER

For sound or noise analysis, the C curve (flat) should generally be used. This gives a direct physical measurement of the relative intensity of each component, and any weighting as a function of frequency can be readily applied as desired. In some cases, the low-frequency components may dominate without being the components of greatest interest. Then the use of the A or the B curve may attenuate the low-frequency components sufficiently to permit one to obtain a more satisfactory comparison.

3.7 INPUT AND OUTPUT IMPEDANCES

The input impedance of the analyzer is approximately 25,000 ohms. The output impedance is approximately 20,000 ohms. A pair of headphones may be plugged into the jack marked PHONES so that the actual tone to which the analyzer is tuned may be heard by the observer. Any impedance may be plugged into the jack without appreciably affecting the readings of the analyzer.

3.8 VIBRATION ANALYSIS

The analyzer may also be used for analyzing vibrations when used with the sound-level meter and a suitable vibration pickup. If the weighting networks included in the sound-level meter are not required, practically any type of amplifier and microphone or vibration pickup may be used in place of the sound-level meter, providing, of course, the amplifier and the pickup have suitable frequency characteristics and low distortion.

3.9 ELECTRICAL WAVE ANALYSIS

Within its amplitude and frequency limits, the Type 760-B Sound Analyzer can be used as a general purpose electric-wave analyzer. Measurement procedure is the same as outlined above under SOUND ANALYSIS, except that the audio-frequency source to be measured is substituted for the sound-level meter.

3.10 USE AS A NULL DETECTOR

The analyzer will be found very useful as a bridge balance indicator for use with practically any type of audio-frequency bridge. Since the analyzer can be tuned to the bridge frequency, any errors due to harmonics in the tone source

GENERAL RADIO COMPANY

or generated by the bridge circuits themselves, will be reduced to a minimum. The analyzer provides a degree of sensitivity on visual balances which is somewhat better than that obtained with head telephones and on untuned amplifiers over most of the audible range. Headphones may also be used on the output of the analyzer for bridge-balancing purposes, with some increase in sensitivity over the meter.

For increased sensitivity, an amplifier can be used between the bridge and the analyzer.

3.11 ANALYSIS ERRORS WHEN USED WITH TYPE 759-A

If the analyzer is connected to the phone jack of the older Type 759-A Sound-Level Meter, errors in analysis will be caused by a small amount of odd order harmonic content produced by the oxide rectifier in the meter of the Type 759-A. This can be improved by replacing the telephone jack on the Type 759-A with a Yaxley Type 702-A two-circuit jack wired to open the meter circuit when the input of the Type 760-B is plugged in. The Type 1551-A and Type 759-B Sound-Level Meters have the output-circuit jack isolated from the meter circuit and a negligible amount of distortion is present.

3.12 ANALYSIS OF NOISE

Frequently the Type 760-B Sound Analyzer is used to make a frequency spectrum analysis of noise. This is true, for example, when an audio amplifier or loudspeaker is tested by using a Broad-band Noise Source, such as the Type 1390-A Random Noise Generator, in place of a sine wave oscillator as a test source. The results of an analysis of noise by the Type 760-B cannot be compared directly with results of analyses by other types of analysers having different band widths. Before comparisons can be made, the results of each type of analyzer must be modified. The usual procedure is to transform the

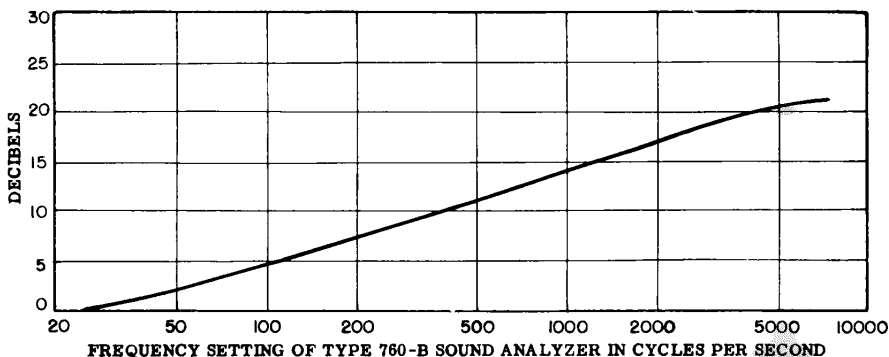

Plot Showing Number of Decibels to be Subtracted from Reading of Analyzer to Obtain Spectral Density Level.

TYPE 760-B SOUND ANALYZER

analysis into an equivalent value for an ideal one-cycle band. When this value is expressed in voltage, it is called here the "spectral voltage density."*

The effective band width of the Type 760-B Sound Analyzer increases with increase in the frequency to which the analyzer is tuned. The graph shown on page 6 shows the value in decibels which is to be subtracted from the reading of the analyzer to obtain the spectral-density level. This value is determined on the basis of initial calibration of the instrument by a sine wave signal.

PART IV

MAINTENANCE

4.1 FOREWORD

4.11 This Service Information, together with the information given in the Operating Instructions, should enable the user to locate and correct ordinary difficulties resulting from normal usage.

4.12 Major service problems should be referred to the Service Department which will cooperate as far as possible by furnishing information and instructions, as well as by shipping any replacement parts which may be required. If the instrument is more than one year old, a reasonable charge may be expected for replacement parts or for complete reconditioning and recalibration if the sound analyzer is returned.

4.13 Detailed facts giving type and serial numbers of the instruments and parts, as well as operating conditions, should always be included in your report to the Service Department.

4.2 GENERAL

If the sound analyzer becomes inoperative, a few simple checks should be made before removing from the case.

4.21 Check battery voltages.

*While convenient, this value in terms of voltage is sometimes not used because most work on noise deals with energy level. The transfer from one to the other requires a knowledge of the impedance level in the circuit. It should be remembered that separate noise signals add on an energy basis and that the noise energy increases directly with the noise band width, while the noise voltage increases as the square root of the band width. Furthermore, the concept used here assumes a uniform density of the noise signal over the band of the analyzer.

GENERAL RADIO COMPANY

4.22 No reading of plate or filament voltages usually results from improper contacts of the battery terminal strip.

4.23 Check installation of batteries per battery location diagram on instruction sheet in instrument cover.

4.3 METER READS INCORRECTLY

4.31 Full scale sensitivity of this meter is 200 microamperes, ac.

4.32 If the meter is defective, a replacement should be ordered from the General Radio Company Service Department. The General Radio Company cannot assume responsibility for any local repairs to the meter, although such repairs might be necessary in an emergency.

4.33 Try changing the V-4 tube, Type 1U4.

4.4 NO SIGNAL ON ONE OR MORE RANGES

4.41 Test for accidental grounds on switch S-1.

4.42 Check connections and contacts on switch S-2 for proper operation.

4.5 GAIN IS LOW

4.51 Low over-all gain can be improved by replacing tubes V-1, V-2, and/or V-3.

4.52 Gain can be increased by resetting potentiometer R-7.

4.6 INSTRUMENT OSCILLATES

4.61 Try varying the setting of potentiometer R-29 slightly. If it is varied too much the over-all frequency characteristic will be affected. If frequency shifts appreciably, readjust R-27 and R-28.

4.62 Check contacts on switch S-1 for open circuits.

4.621 All ranges lower in frequency than the one having the open circuit will also oscillate.

4.63 If oscillation is on "E" range:

4.631 Reduce R-38 from 1.5 megohms to 0.75 megohms, which will reduce the feedback.

4.632 Increase C-45 by 0.001 microfarad.

4.7 SENSITIVITY

4.71 Sensitivity on any one frequency range can be increased by adding a parallel condenser to the circuit for that range (C-31 for A, C-32 for B, etc.).

TYPE 760-B SOUND ANALYZER

4.72 Sensitivity on any one frequency range can be decreased by adding approximately equal condensers to series condensers for that range (C-11 and C-21 for A, C-12 and C-22 for B, etc.).

4.721 D range condensers include E range condensers; C range condensers include D and E range condensers, etc. Therefore, a defective condenser in the E circuit would cause a small error on all the other ranges. However, a bad condenser in the A circuit would only affect the A range.

4.73 Always adjust, beginning with the high-frequency range, before proceeding as in 4.71 and 4.72, as change in capacity to make corrections in any particular range will also affect slightly the next lower range.

4.74 To decrease sensitivity of E range, increase R-38. Change will be greater at the low end of the range. Decreasing will act the reverse, but its effect will again be greater at the low end.

4.8 VACUUM TUBE DATA

The table below lists voltages measured between socket terminals and ground using a 20,000 ohms per volt meter (Weston 772 Analyzer). Voltage may vary as much as +20%, except as noted.

SYMBOL	TYPE	SOCKET PIN NUMBER								FUNCTION
		1	2	3	4	5	6	7	8	
V-1	1L4	1.1	23.0	23.0			0	1 and 7 1.4		AMPLIFIER
V-2	1L4	27	55.0	56.0			23.0	1 and 7 1.4		AMPLIFIER
V-3	1L4	60	100	100			56.0	1 and 7 1.4		AMPLIFIER
V-4	1U4	0	67	105	110	0	-1v.*	1 and 7 1.4		AMPLIFIER
V-5	G.E. NE-51	60 v. from high terminal to ground								PILOT LIGHT

*Use 50-volt range

PARTS LIST

CAPACITORS

C-1	=	0.1	μf	+10%	COW-16	
C-2	=	0.025	μf	+10%	COM-508	
C-3	=	1.5	μf	+10%	COWB-7	
C-4	=	0.2	μf	+10%		
C-5	=	0.8	μf	+10%		
C-6	=	100.0	μf	150 DCWV		COE-28-2
C-7	=	8.0	μf	+10%		COWB-8
C-8	=	12.0	μf	+10%	Part of COWB-9	
C-9	=	3.0	μf	+10%		
C-11	=	0.08	μf	+2%	ZCOP-8-5	
C-12	=	0.028	μf	+2%	ZCOP-8-1	
C-13	=	0.008	μf	+2%	ZCOP-8-1	
C-14	=	0.0028	μf	+2%	ZCOP-7-1	
C-15	=	0.00113	μf	+3%	ZCOP-7-1	
C-16	=	10 - 100	μμf		COT-24	
C-21	=	0.08	μf	+2%	ZCOP-8-5	
C-22	=	0.028	μf	+2%	ZCOP-8-1	
C-23	=	0.008	μf	+2%	ZCOP-8-1	
C-24	=	0.0028	μf	+2%	ZCOP-7-1	
C-25	=	0.00113	μf	+3%	ZCOP-7-1	
C-26	=	10 - 100	μμf		COT-24	
C-31	=	0.16	μf	+1/2%	ZCOP-8-5	
C-32	=	0.056	μf	+1/2%	ZCOP-8-1	
C-33	=	0.016	μf	+1/2%	ZCOP-8-1	
C-34	=	0.0056	μf	+1/2%	ZCOP-7-1	
C-35	=	0.00235	μf	+0 - 3%	ZCOP-7-1	
C-36	=	10 - 100	μμf		COT-24	
C-41	=	0.1	μf	+10%	Part of COWB-9	
C-42	=	0.03	μf	+10%		
C-43	=	0.01	μf	+10%		
C-44	=	0.003	μf	+10%		
C-45	=	0.0022	μf	+10%	COL-71	
C-46	=	50.0	μμf	+10%	COM-20B	
C-47	=	1.0	μf	+10%	COW-16	
C-48	=	16.0	μf	150 DCWV	COE-4	
C-49	=	1.0	μf	+10%	COW-16	

RESISTORS

R-1	=	1	MΩ	+10%	REC-20BF
R-2	=	220	KΩ	+10%	REC-20BF
R-3	=	18	KΩ	+10%	REC-20BF
R-4	=	62	KΩ	+5%	REC-20BF
R-5	=	51	KΩ	+5%	REC-20BF
R-6	=	100	KΩ	+20%	
R-7	=	50	KΩ	+10%	POSC-11
R-8	=	39	KΩ	+5%	REC-20BF
R-9	=	1	MΩ	+1%	C.C.Co. X-1/2
R-10	=	250	KΩ	+1%	C.C.Co. X-1/2
R-11	=	10	KΩ	+10%	REC-20BF
R-12	=	1.8	MΩ	+10%	REC-20BF
R-13	=	180	KΩ	+5%	REC-20BF
R-14	=	10	KΩ	+10%	REC-20BF
R-17	=	50	KΩ	+10%	POSC-11
R-19	=	13	KΩ	+5%	REC-20BF
R-23	=	1.3	MΩ	+5%	REC-20BF
R-24	=	11	KΩ	+5%	REF-2
R-25	=	11	KΩ	+5%	REF-2
R-26	=	5.5	KΩ	+5%	REF-2
R-27	=	5	KΩ	+10%	POSC-11
R-28	=	5	KΩ	+10%	POSC-11
R-29	=	2.5	KΩ	+10%	POSC-11
R-30	=	44.9	KΩ	}	760-350
R-31	=	44.9	KΩ		
R-32	=	44.9	KΩ		
R-33	=	44.9	KΩ		
R-34	=	18	KΩ	+10%	REC-20BF
R-37	=	10	KΩ	+10%	POSC-12
R-38	=	2.4	MΩ	+10%	REC-20BF
R-39	=	1	KΩ	+10%	POSC-11
R-40	=	10	KΩ	+10%	REC-20BF
R-41	=	50	KΩ	+10%	POSC-11
R-42	=	820	Ω	+10%	REC-20BF
R-43	=	10	KΩ	+10%	REC-20BF

REC- = JAN RC-
COM- = JAN CM-

SWITCHES

S-1	=	SWPM-15
S-2	=	SWPM-992-3
S-3	=	SWP-940-2
S-4	=	SWT-320

M-1	=	200 μa ±5%	MERS-2
B-1	=	1-1/2 volts	2BAC-4

TUBES

V-1	=	1L4
V-2	=	1L4
V-3	=	1L4
V-4	=	1U4
V-5	=	G.E. NE-51

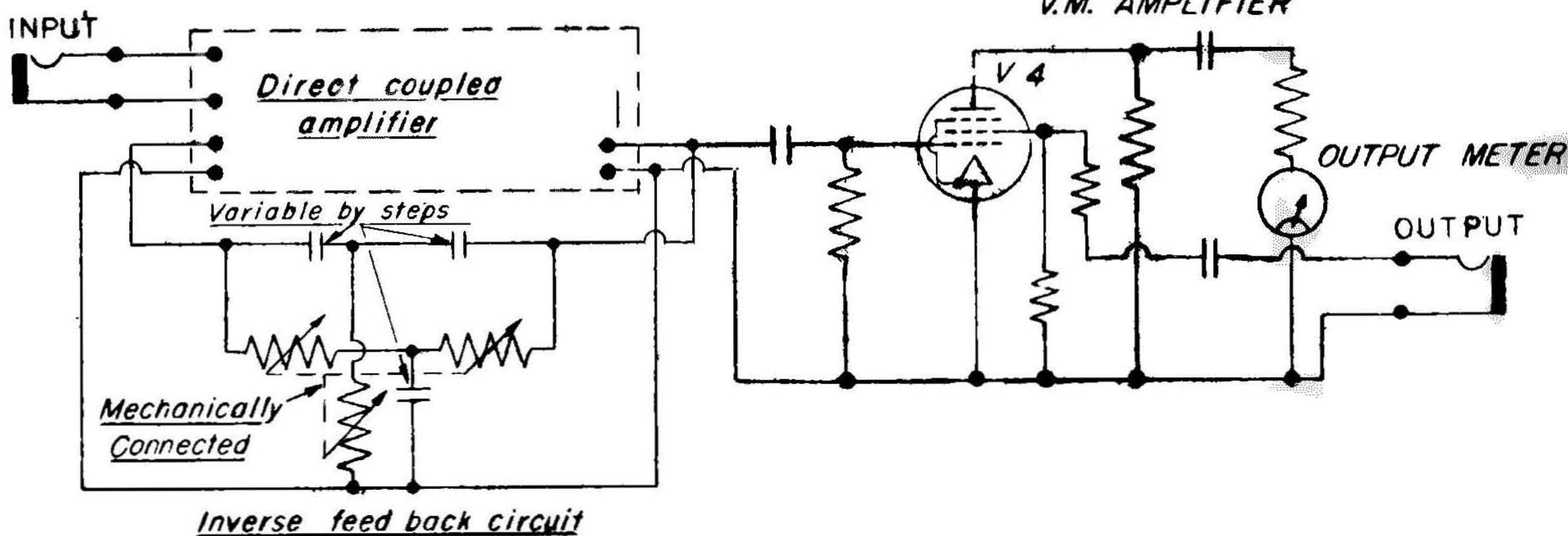

Figure 3. Schematic Diagram of Type 760-B Sound Analyzer.

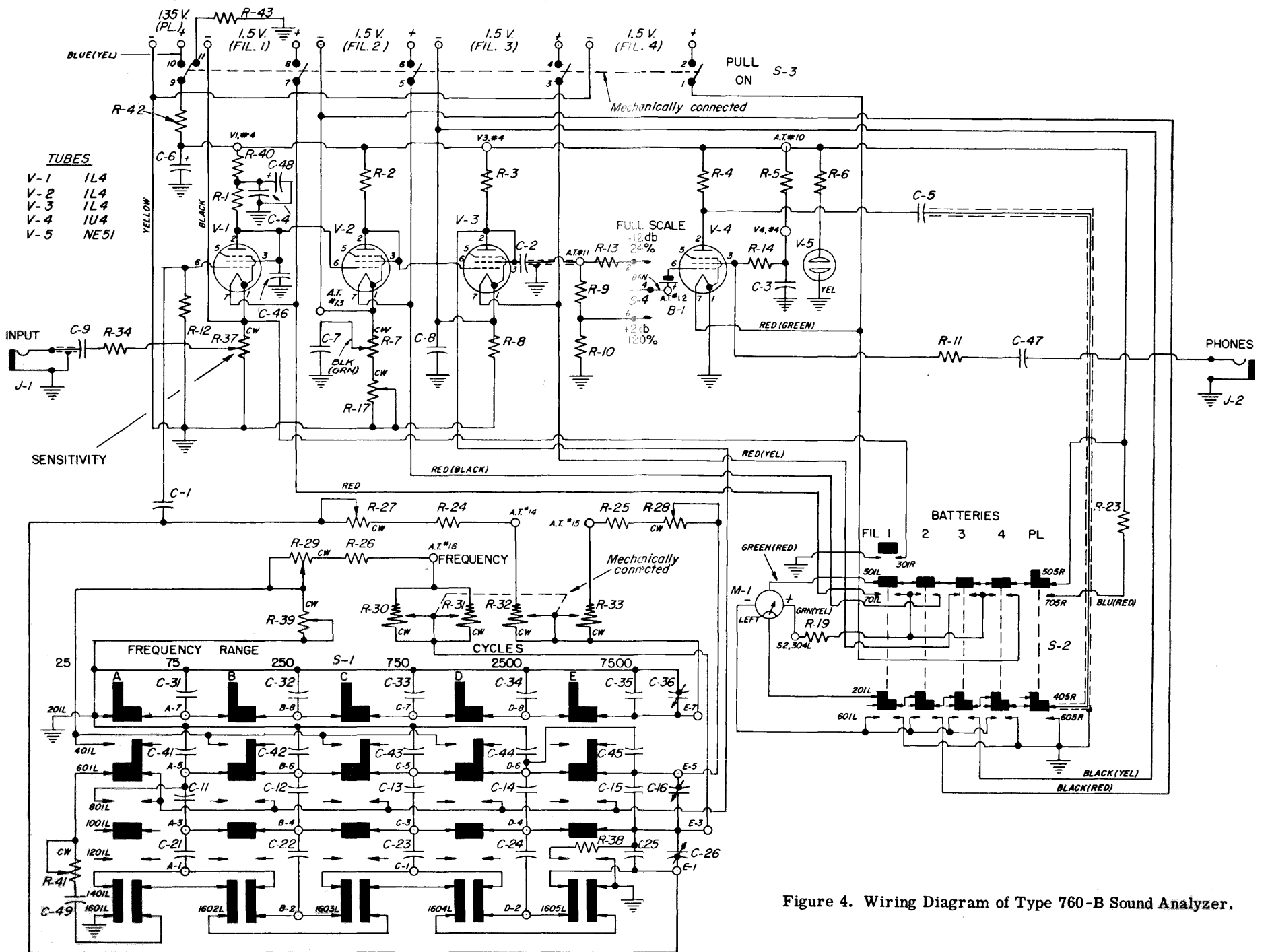

Figure 4. Wiring Diagram of Type 760-B Sound Analyzer.

