

OPERATING INSTRUCTIONS

TYPE 1206-B UNIT AMPLIFIER

A
GR
UNIT
INSTRUMENT

... SINCE 1915
*manufacturers of
electronic apparatus
for science and industry*

GENERAL RADIO COMPANY
CAMBRIDGE 39, MASSACHUSETTS, USA

OPERATING INSTRUCTIONS

TYPE 1206-B UNIT AMPLIFIER

Form 825-C
October, 1957

GENERAL RADIO COMPANY
275 MASSACHUSETTS AVENUE
CAMBRIDGE 39 MASSACHUSETTS

SALES ENGINEERING OFFICES

NEW YORK: Broad Avenue at Linden
Ridgefield, New Jersey

CHICAGO: 6605 West North Avenue
Oak Park, Illinois

PHILADELPHIA: 1150 York Road
Abington, Pennsylvania

WASHINGTON: 8055 13th Street
Silver Spring, Maryland

LOS ANGELES: 1000 North Seward Street
Los Angeles 38, California

SAN FRANCISCO: 1182 Los Altos Avenue
Los Altos, California

REPAIR SERVICES

WEST COAST

Western Instrument Company
826 North Victory Boulevard
Burbank, California

EAST COAST

General Radio Company
Service Department
275 Massachusetts Avenue
Cambridge 39, Massachusetts

CANADA

Bayly Engineering, Ltd.
First Street
Ajax, Ontario

Printed in U.S.A.

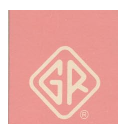

SPECIFICATIONS

Power Output: With 300-v plate supply, 600-ohm load: from 10 cps to 50 kc, 3 w; from 5 cps to 100 kc, 1.5 w; at 250 kc, 0.5 w.

Distortion: Less than 1% harmonic distortion with 2-w output (2% at 3 w) into 600 ohms from 20 cps to 40 kc.

Pulse Response:	<u>No Load</u>	<u>600 Ω</u>
Droop in 30-cps square wave:	15%	20%
Approx rise time: 50 v peak-to-peak:	1 μsec	2 μsec
100 v peak-to-peak:	2 μsec	4 μsec
Max output, peak-to-peak:	260 v	120 v

Load Impedance: 600 ohms optimum. Blocking capacitor is 100 μf. (Internal impedance about 100 ohms.)

Input Impedance: 100,000 ohms in parallel with 35 μf.

Frequency Response: Down less than 3 db at 2 cps and 500 kc at 10-v (or less) output, with gain control at maximum. See also Power Output, above.

Voltage Gain: Continuously adjustable. Maximum gain is 50 to 1 (34 db), with no load.

A-C Hum in Output: Less than 15 mv rms, with Type 1203 Unit Power Supply; less than 3 mv rms, with Type 1201-A Unit Regulated Power Supply.

Power Requirements: 300 v at 50 ma; 6.3 v at 2.7 amp.

Power Supply: Type 1203 Unit Power Supply is recommended. Amplifier plugs directly into any one of the Unit Power Supplies.

Accessories Supplied: Multipoint connector, and connector channels for attaching power supplies.

Mounting: Black-crackle-finished panel and sides. Aluminum cover finished with clear lacquer. Relay Rack panel (Type 480-P4U3) available for amplifier and power supply.

Dimensions: Width 9-7/8 in., height 5-3/4 in., depth 6-1/4 in., over-all.

Weight: 4 lb.

U.S. Patent No. 2,659,775 and 2,802,907.

GENERAL RADIO EXPERIMENTER reference: Volume XXVII No. 6,
November, 1953

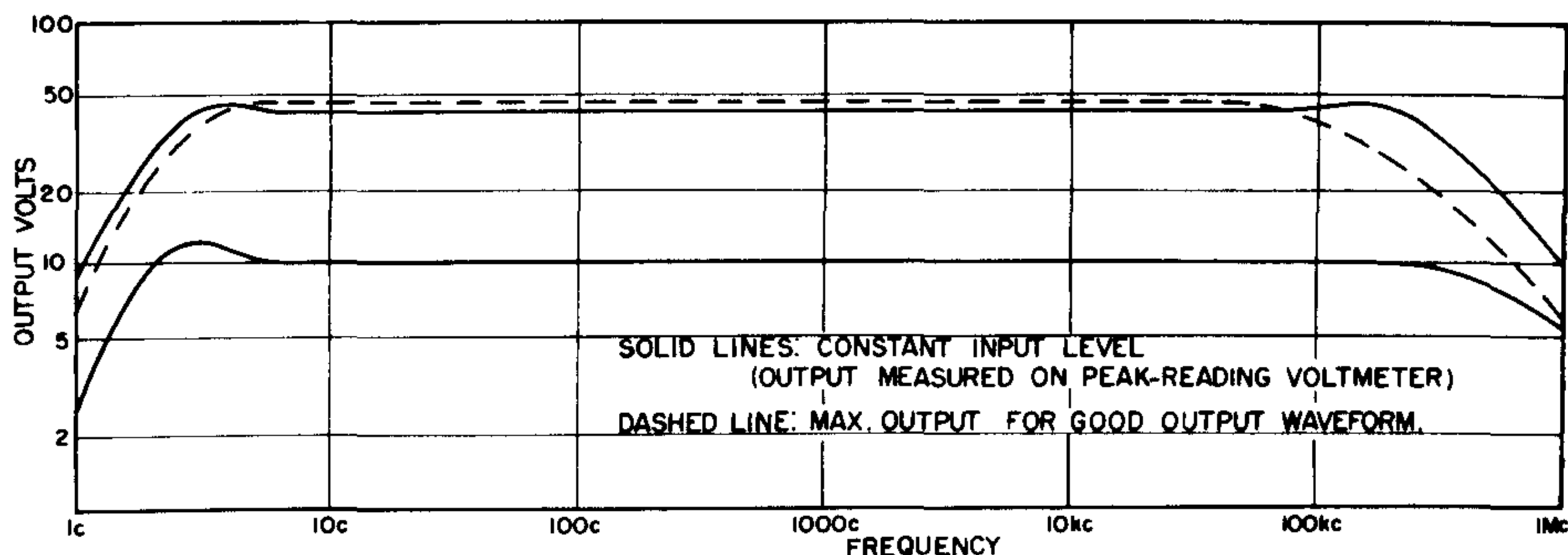

Frequency-Response with 600-Ohm Load.



Figure 1. Panel View, Type 1206-B Unit Amplifier.

TYPE 1206-B UNIT AMPLIFIER

Section 1 INTRODUCTION

1.1 PURPOSE. The Type 1206-B Unit Amplifier (Figure 1) is designed as a general-purpose laboratory instrument useful as a bridge amplifier, a driver for low-power electronic and electroacoustic devices, and as an amplifier for the Type 1210-B Unit Oscillator and other low-power signal sources. The normal operating range covers the audio and ultrasonic frequencies.

1.2 DESCRIPTION. The Unit Amplifier uses a single-ended push-pull circuit,¹ with the advantage of push-pull operation of the output tubes and without the usual low- and high-frequency limitations of the output transformer. The circuit consists of a triode amplifier stage, a phase inverter, and series output tubes operated in push-pull parallel. Degenerative feedback is returned to the cathode of the input stage.

The elementary schematic diagram (Figure 2) shows the operation of the series push-pull output stage. Note that the drive for the upper tube (V3) is applied from grid to cathode and not from grid to ground. If either tube were replaced by a resistor, therefore, the other would act as an amplifier with gain, and the upper tube would give an output in phase with its input.

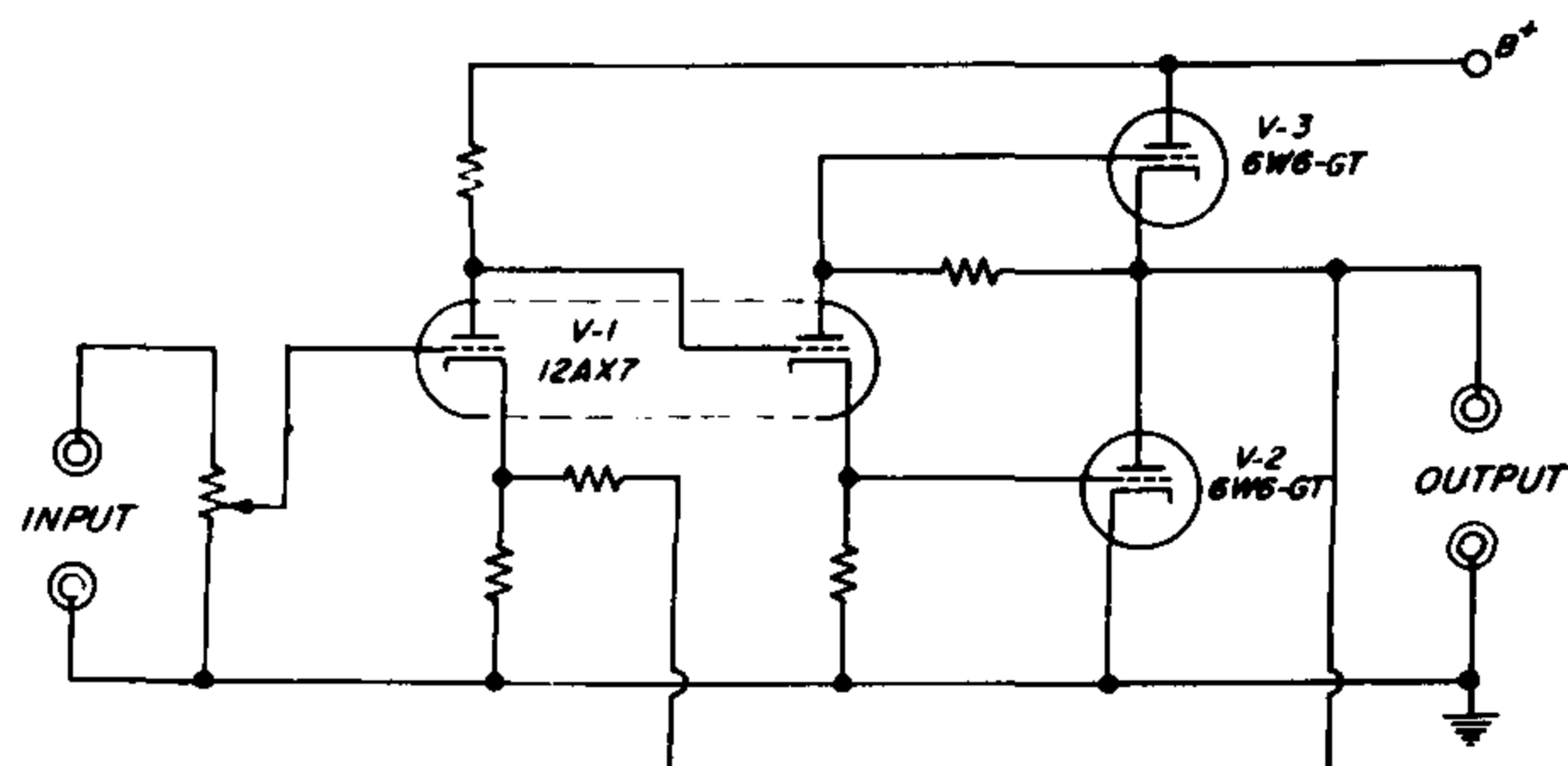

Figure 2. Elementary Schematic Diagram.

1. Peterson, A.P.G. and Sinclair, D.B., "A Single-Ended Push-Pull Audio Amplifier", Proc. IRE, January, 1952, pp. 7-11.

Section 2

OPERATING PROCEDURE

2.1 POWER SUPPLY. Connect an external power source to the connecting jack as shown in Figure 3. Recommended power sources are the Type 1203-A Unit Power Supply, Type 1201-A Unit Regulated Power Supply, and Type 1204-B Unit Variable Power Supply. The power supply should be able to deliver 2.7 amp at 6.3 volts (60 cps) and 50 ma at 300 volts dc. The heater supply and the d-c plate supply should not be interconnected. When using the Type 1204-B Unit Variable Power Supply, set the output to 300 volts.

If the Type 1203-A Unit Power Supply is used, it will not be possible to obtain the full 3 watts output if the line voltage is substantially below 115 volts. A Variac or other means of increasing line voltage should be used if the full 3 watts are desired. At line voltages of over 115 volts, an output of over 3 watts is obtainable; however, the amplifier should not be operated from the Type 1203-A Unit Power Supply with a line voltage of over 130 volts.

The Type 1201-A Unit Regulated Power Supply supplies 300 volts regulated power, and also has the advantage of reducing the hum output of the amplifier.

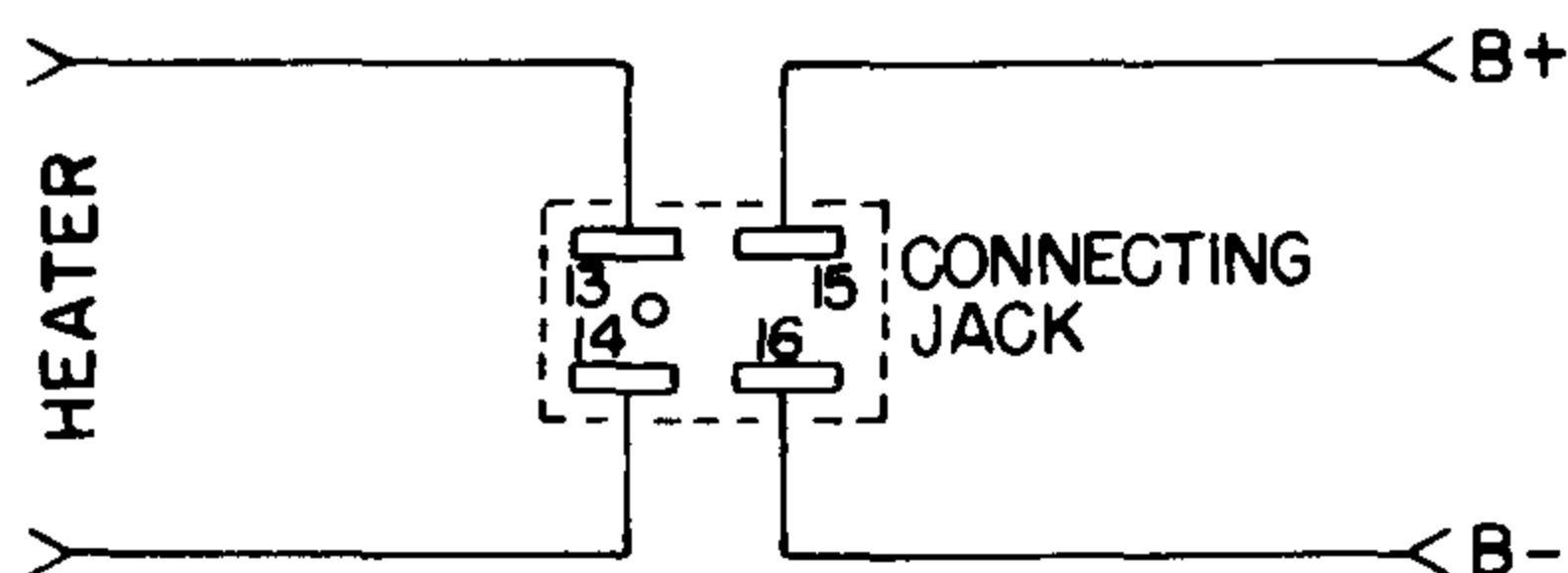

Figure 3.
Connection of External
Power Source.

2.2 INPUT AND OUTPUT CIRCUITS. The INPUT and OUTPUT terminals are so indicated on the front panel. Be careful to keep the external input and output connections separate to prevent oscillation due to an external feedback path.

Each INPUT terminal is connected to one end of a logarithmic potentiometer (R1), whose variable tap is connected to a blocking capacitor that leads to the grid of the input stage. The input, therefore, may have a d-c component, which should be under 100 volts. The 100,000-ohm potentiometer (R1) should be turned fully clockwise for full gain.

Leakage in the 100- μ f blocking capacitor in the output circuit results in a d-c voltage across the output terminals. The voltage is about 1 volt open-circuit, 0.1 volt with a 600-ohm load.

TYPE 1206-B UNIT AMPLIFIER

The optimum load is 600 ohms. Due to feedback, the actual source impedance is about 100 ohms, but the amplifier cannot supply enough current to develop 3 watts into a load impedance much smaller than 600 ohms.

2.3 FREQUENCY RESPONSE. The frequency ranges given for various power levels (refer to Specifications) are the ranges over which the output waveform is essentially sinusoidal for a sinusoidal input. Any given output is available over a wider frequency range than indicated, but the waveform is visibly distorted at frequencies much beyond those given.

High-frequency response is a function of amplitude, and is due to the limited frequency response of the phase inverter, which results in overloading of the phase inverter at high frequencies.

Although this series-tube operation permits a much better frequency response than that which is ordinarily possible with an output transformer and conventional push-pull circuit, the response is limited by the effective multiplication of the grid-to-ground capacitance of the upper tube by the gain of the output stage.

2.4 PULSE RESPONSE. The Specifications indicate that the rise time is a function of amplitude. This is due to the limited response of the phase inverter, which results in overloading of the phase inverter. At low levels the rise time of the phase inverter is improved by feedback. At sufficiently high levels the phase inverter is driven to cutoff. At cutoff, the impedance of the tube's output circuits is changed so that the circuit has a longer time constant and slower rise time. The period of time over which cutoff exists depends on the amplitude. The fall time is shorter, indicating that driving the phase inverter grid positive has less effect on the time constants of the phase inverter's output circuits.

With potentiometer R1 turned fully clockwise, a small overshoot appears on the output waveform when the amplifier is driven from a low-impedance pulse generator. To eliminate this overshoot, turn R1 slightly counterclockwise. The rise time, however, is best when R1 is near either end.

Section 3

SERVICE AND MAINTENANCE

3.1 GENERAL. The following information, together with that given in preceding paragraphs, should enable the user to locate and correct ordinary difficulties resulting from normal use. Major service problems should be referred to our Service Department, which will co-operate as much as possible by furnishing information and instructions as well as by supplying replacement parts needed.

GENERAL RADIO COMPANY

When notifying our Service Department of any difficulties in operation or service of the instrument, always mention the serial and type numbers of the instrument. Also include in correspondence a report of trouble encountered, as well as information concerning use of the instrument and steps taken to eliminate the trouble.

Before returning an instrument for repair, please write to our Service Department, requesting a Returned Material Tag, which includes shipping instructions. Use of this tag will insure proper handling and identification when an instrument or parts are returned for repair. A purchase order covering repair to material returned should also be forwarded to avoid unnecessary delay.

3.2 EXCESS DISTORTION. Excess distortion would probably be due to improper operation of the output tubes. Before replacing either of the tubes, check to see that the plate supply voltage (V3, pins 3 and 4) and the bias voltage (V2, pin 5) are correct. After replacing either V2 or V3, readjust R13 for minimum distortion. R13, a bias adjustment on V3, is set at the factory to give minimum distortion at 1 kc when delivering 3 watts into 600 ohms with a line voltage of 115 volts on the Type 1203-A Unit Power Supply.

3.3 LOW GAIN OR EXCESS HUM. In the event of either low gain or excessive hum, check to see if V1 (12AX7) is defective, and replace it if necessary.

3.4 TEST VOLTAGES. The following table gives test voltages as an aid to trouble-shooting. Unless otherwise indicated, voltages are dc, to ground, with no input signal applied. A 20,000-ohm-per-volt multimeter was used.

TUBE		PIN	VOLTS TO GND	TUBE		PIN	VOLTS TO GND
V1 (12AX7)	Plate	1	200	V2 (6W6-GT)	Heater	2	6.3 ac**
	Grid	2	0		Plate	3	150†
	Cathode	3	1.6		Screen	4	150†
	Heater	4	-8		Grid	5	-16
	Heater	5	-8		Heater	7	-8
	Plate	6	250	Cathode	8	0	
	Grid	7	High Impedance	V3 (6W6-GT)	Heater	2	6.3 ac**
	Cathode	8	40		Plate	3	300
	Heater	9	6.3 ac*		Screen	4	300
			Grid		5	134†	
				Heater	7	-8	
				Cathode	8	150†	

* Between pins 4 and 9 and pins 5 and 9.

** Between pins 2 and 7.

† Value may change considerably

TYPE 1206-B UNIT AMPLIFIER

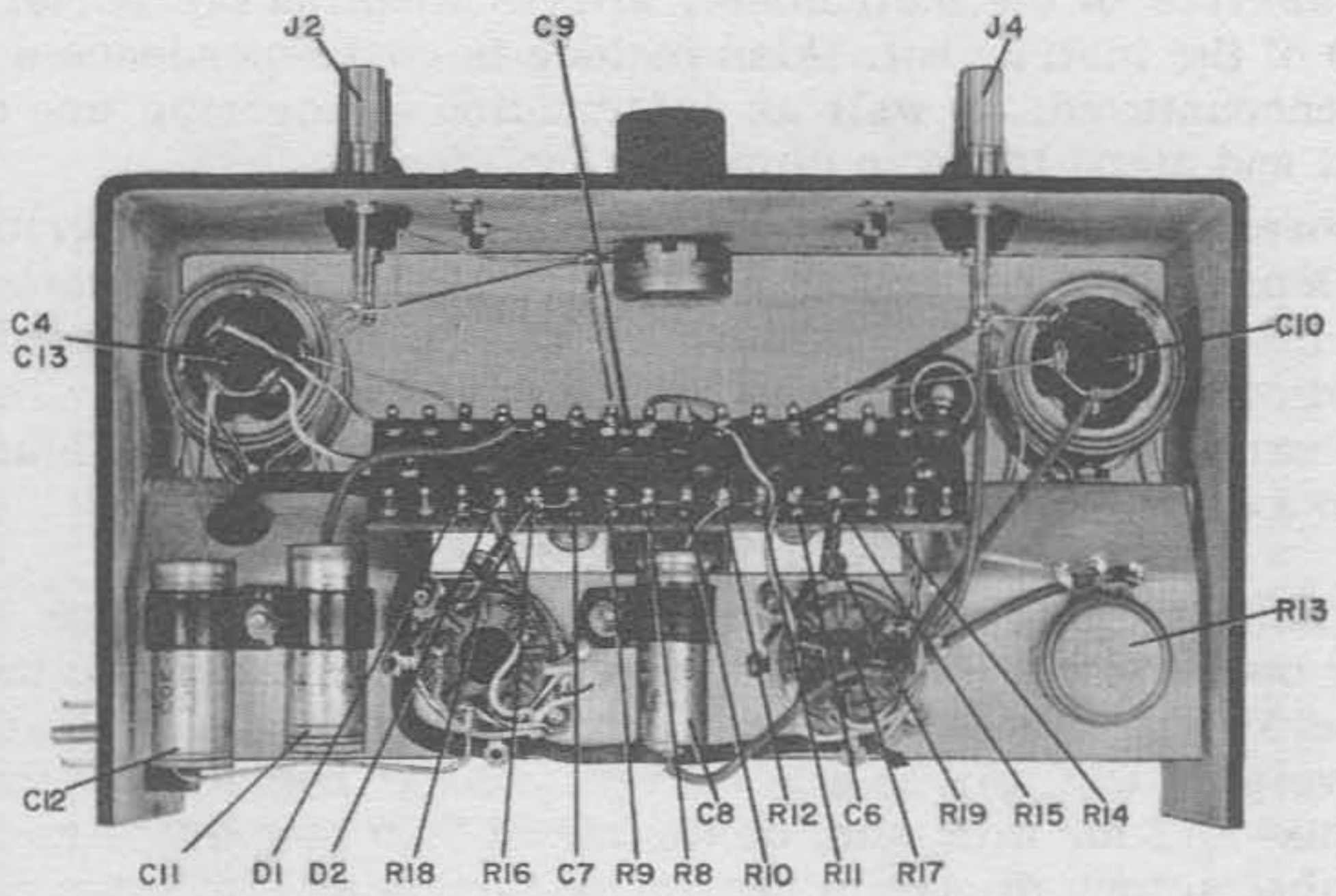

Figure 4. Top Interior View.

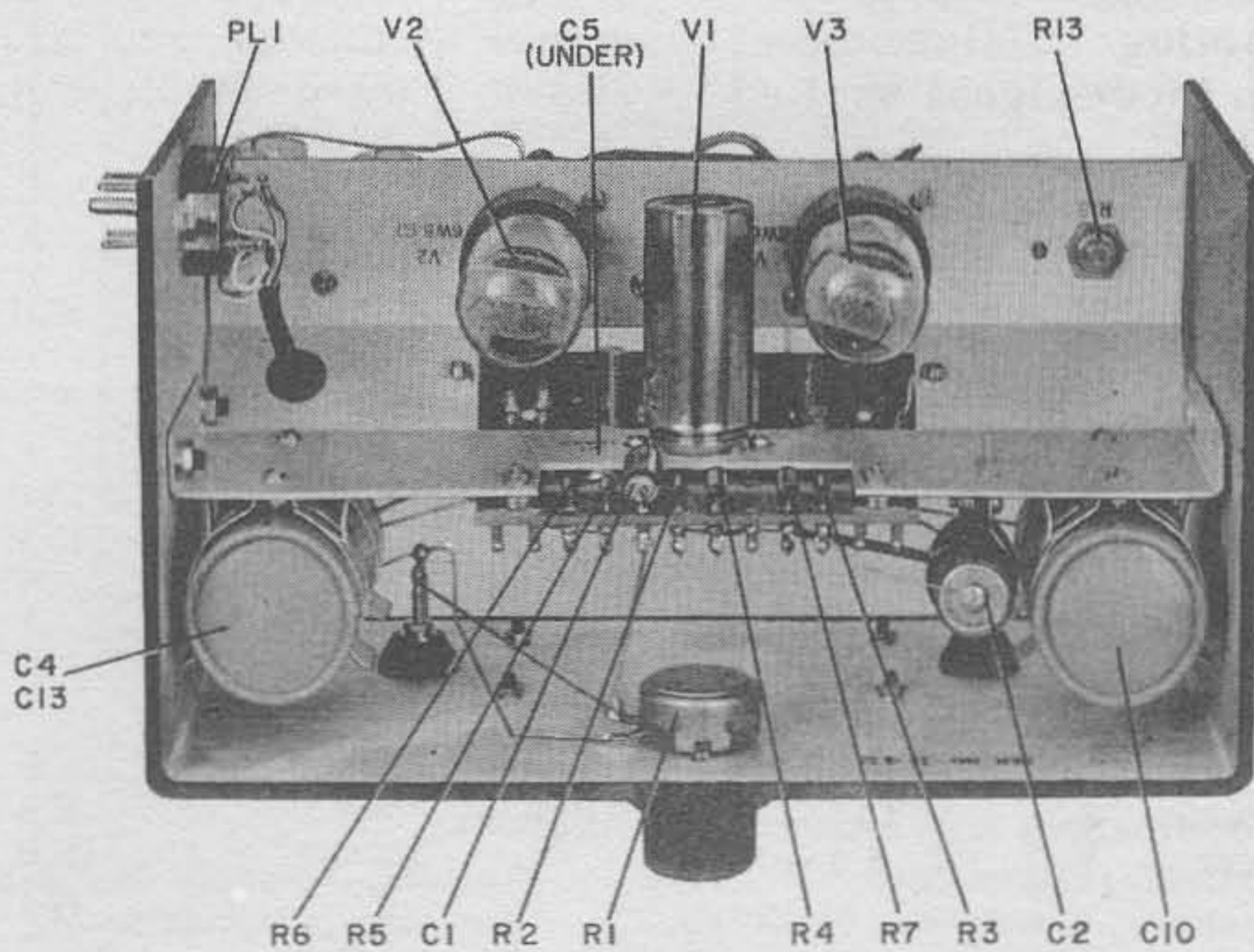

Figure 5. Bottom Interior View.

GENERAL RADIO COMPANY

PARTS LIST

GR No.
(Note A)

RESISTORS (Note B)	R1	100	k	±10%		POSC-12
	R2	1	m	±10%	1/2 w	REC-20BF
	R3	1	k	±10%	1/2 w	REC-20BF
	R4	200		± 1%	1/2 w	REF-2
	R5	68	k	± 5%	1/2 w	REC-20BF
	R6	10	k	±10%	1/2 w	REC-20BF
	R7	13	k	± 1%	1/2 w	REF-2
	R8	1	m	±10%	1/2 w	REC-20BF
	R9	1.5	k	± 5%	1/2 w	REC-20BF
	R10	39	k	± 1%	1/2 w	REF-2
	R11	28.5	k	± 1%	1/2 w	REF-2
	R12	27	k	±10%	1/2 w	REC-20BF
	R13	5	m	±20%		POSC-11
	R14	8.2	m	±10%	1/2 w	REC-20BF
	R15	1	m	±10%	1/2 w	REC-20BF
	R16	100	k	±10%	1/2 w	REC-20BF
	R17	4.7	m	±10%	1/2 w	REC-20BF
	R18	100		±10%	1/2 w	REC-20BF
	R19	100		±10%	1/2 w	REC-20BF
CAPACITORS (Notes C and D)	C1	0.1		±10%	100 dcwv	COW-17
	C2	200		+100%-10%	10 dcwv	COE-6
	C4	25		+0-10%	350 dcwv	COEB-35
	C5	0.047		±10%	400 dcwv	COW-25
	C6	0.1		±10%	200 dcwv	COW-16
	C7	0.22		±10%	100 dcwv	COW-17
	C8	10		+0-10%	250 dcwv	COE-33
	C9	39	μf	±10%	500 dcwv	COM-20B
	C10	100		+0-10%	350 dcwv	COEB-35
	C11	16		+100%-10%	150 dcwv	COE-4
	C12	16		+100%-10%	150 dcwv	COE-4
	C13	75		+0-10%	350 dcwv	COEB-35
		D1	Crystal Diode			
	D2	Crystal Diode				IN34-A
	J1	Binding Post				BP-5
	J2	Binding Post				BP-5
	J3	Binding Post				BP-5
	J4	Binding Post				BP-5
	PL1	Plug				CDMP-476-4

NOTES

- (A) Type designations for resistors and capacitors:
- | | | | |
|------|---------------------------------|------|-----------------------------------|
| COE | - Capacitor, electrolytic | POSC | - Resistor, variable, composition |
| COEB | - Capacitor, electrolytic block | REC | - Resistor, composition |
| COM | - Capacitor, mica | REF | - Resistor, film |
| COW | - Capacitor, wax | | |
- (B) All resistances are in ohms unless otherwise indicated by k (kilohms) or M (megohms).
- (C) All capacitances are in microfarads unless otherwise indicated by μf (micromicrofarads).
- (D) C4 and C13 are parts of the same unit.

- KNOB CONTROL
- ⊗ SCREW DRIVER ADJUSTMENT

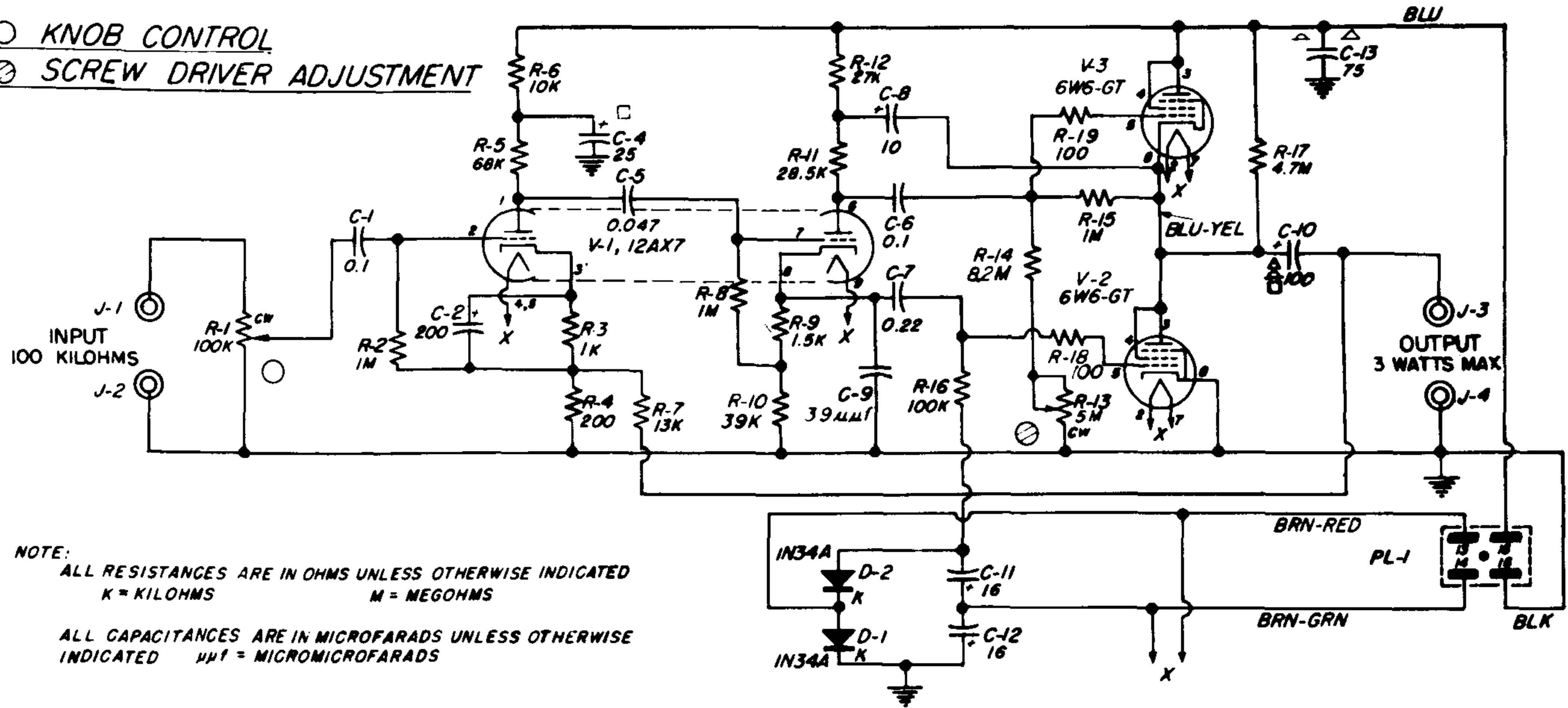

NOTE:
 ALL RESISTANCES ARE IN OHMS UNLESS OTHERWISE INDICATED
 K = KILOHMS M = MEGOHMS
 ALL CAPACITANCES ARE IN MICROFARADS UNLESS OTHERWISE INDICATED
 μμf = MICROMICROFARADS

Figure 6. Schematic Diagram, Type 1206-B Unit Amplifier.



