

OPERATING INSTRUCTIONS

FOR

TYPE 625-A BRIDGE

FORM 353-A



GENERAL RADIO COMPANY
CAMBRIDGE A, MASSACHUSETTS



FIGURE 1. Type 625-A Bridge.

GENERAL RADIO COMPANY

OPERATING INSTRUCTIONS FOR TYPE 625-A BRIDGE

PART I DESCRIPTION

The Type 625-A Bridge consists of a skeleton bridge circuit with provision for plugging in standard and unknown units to obtain a variety of circuits.

The main feature of the bridge is a large dial which is used for balance and which forms one of the ratio arms. The bridge contains both a d-c and a 1000-cycle a-c source of voltage. Provision is made for operation from an external source.

When combined with suitable standard arms, the bridge can be used for the measurement of resistance, inductance, or

capacitance. Direct current or alternating current for frequencies up to 5000 cycles may be used as a bridge source.

The accuracy which will be obtained depends, of course, upon the type of standards used. With the equipment recommended in this instruction book the accuracy should be 2% for measurements of resistance, inductance, and capacitance, provided instructions are followed. The accuracy of the portions of the circuit contained within the Type 625-A Bridge is 1%.

PART II INSTALLATION

A 4.5-volt (Burgess 2370 or Eveready 711) battery must be installed. This is placed in the compartment at the rear of the cabinet. The panel can be lifted out after removing the thumbscrews at the corners. The control switch should be placed in the EXT. ON INT. OFF position.

The bridge should be set up to form one of the circuits shown in PART III and PART IV, depending on the type of measurement to be made. Telephones should be connected to the terminals marked DET for a-c measurements. A gain in sensitivity will result from the use of an amplifier such as the General Radio Type 514-A Amplifier between the bridge and the telephones. If d-c measurements are to be made, a 200- μ a center-scale galvanometer should be connected to the terminals marked DET.

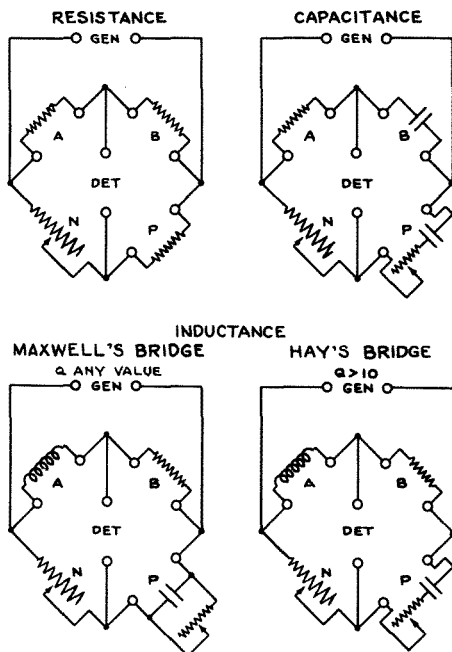

FIGURE 2. Although practically every bridge circuit can be used with the Type 625-A Bridge, the four circuits shown schematically in this drawing are the most convenient.

GENERAL RADIO COMPANY

PART III MAKING DIRECT-CURRENT MEASUREMENTS

RESISTANCE The circuit of Figure 3 is used. The proper values for A and B arms are selected from Table I below.

The range of values for the unknown resistor given in Table I under "Range for Greatest Accuracy" is read on the N dial between 1.0 and 10. The total range uses dial settings down to 0.1.

Scale settings below 0.1 are useful only in measurements in which the resistance of the bridge itself is of importance. The measurement should be made by taking the difference of the dial readings with the K terminals shorted and with the unknown connected, multiplied by 0.1, as shown in the last column of Table I. By using such zero corrections resistances up to 0.2 ohm may be measured to 0.002 ohm and above 0.2 ohm to 1%.

It is desirable to shunt the galvanometer when beginning a measurement. The shunt is gradually removed as balance is approached. Great care should be taken to change the arms in small steps when the unshunted galvanometer is connected. Check and, if necessary, set the zero of the galvanometer.

Set GENERATOR switch to DC.

Rotate the N dial slowly in the proper direction to bring the galvanometer toward zero. As zero is approached, lessen the galvanometer shunt (increase its resistance).

When the galvanometer reads zero, the bridge is in balance.

The value of the unknown resistance, P, is found from the relation

$$P = 1000 N \frac{B}{A}$$

where B and A are expressed in ohms and N is the reading of the N dial.

The scale reading of the N dial is its resistance in kilohms. For convenience the value of the multiplying factor $1000 \frac{B}{A}$ is given in Table I.

EXTERNAL BATTERY When high resistances are measured, the sensitivity of the bridge may be increased by the use of higher voltage in the supply. Voltages up to 45 volts may be used without injury to the N dial or connections. The current-carrying capacity of the other arms used should, of course, be checked before applying higher voltages.

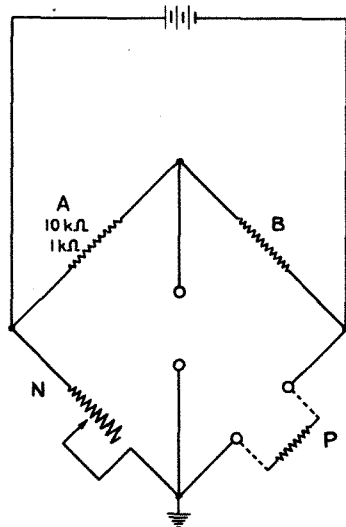

FIGURE 3. Conventional Wheatstone Bridge for the measurement of d-c resistance.

TABLE I

Unknown Resistor P		Ratio Arms		Multiplying Factor for N Dial
Range For Greatest Accuracy	Total Range	A	B	
100,000Ω - 1,000,000 Ω	100,000Ω - 1,000,000Ω	100 Ω	10,000Ω	100,000
10,000Ω - 100,000 Ω	1000Ω - 100,000Ω	1000 Ω	10,000Ω	10,000
1000Ω - 10,000 Ω	100Ω - 10,000Ω	10,000 Ω	10,000Ω	1000
100Ω - 1000 Ω	10Ω - 1000Ω	10,000 Ω	1000Ω	100
10Ω - 100 Ω	1Ω - 100Ω	10,000 Ω	100Ω	10
1Ω - 10 Ω	0.1Ω - 10Ω	10,000 Ω	10Ω	1
0.1Ω - 1 Ω	0.01Ω - 1Ω	10,000 Ω	1Ω	0.1

GENERAL RADIO COMPANY

PART IV ALTERNATING-CURRENT MEASUREMENTS

RESISTANCE The circuit and procedure is identical with that for direct current, except that the GENERATOR switch is placed at the 1 KC position and telephones are used for balance. The balance occurs when the sound intensity in the telephones is a minimum. It may be found that no null is obtained but that the minimum sound occurs at one end of the N dial. If at the low end, the A and B arms should be changed to the combination for the next lower range of unknown value. Similarly, if the minimum is at the high end, use the combination for the next higher ranges (See Table I, Page 2).

The criterion of a good balance is that the 1000-cycle note is reduced in audibility to the point that the passage of the sliding contact over the individual wires may be detected.

If the resistance under measurement has a considerable reactance, a balance may be obtained by connecting a variable condenser between the junction of arms B and P and one of the external detector terminals. Connect to the lower (G) terminal if the resistor is inductive, and to the upper terminal if it is capacitive.

CAPACITANCE Use the circuit of Figure 4. Select the proper values for the A and P arms from Table II below.

That part of the scale of the N dial between zero and 0.1 is useful in measuring small capacitances where the zero capacitance of the bridge is important. To do this, it is necessary to take the difference of the dial readings with the unknown capacitance connected and disconnected, multiplied by 0.0001, as shown in the last column of Table II.

The values for added resistance in the P arm for various values of condenser dissipation factor $R\omega C$ are shown in Table III. It is recommended that Type 526 Rheostat-Potentiometers be used for this purpose.

Connect telephones to DET terminals; place GENERATOR switch on 1 KC position;

TABLE III

C_p	R_p	Dissipation Factor (D_B)
1 μf	0 - 100 Ω	0-0.6
0.01 μf	0 - 10,000 Ω	0-0.6
1000 μf	0 - 100,000 Ω	0-0.6

place 1 KC GENERATOR IMPEDANCE switch on LOW if the impedance of the A arm is less than about 100 ohms, on HIGH, if it is greater than that value. Ground the bridge at the terminal marked G.

Proceed to balance the bridge as follows:

Turn the N dial until minimum sound intensity is obtained. Increase the set-

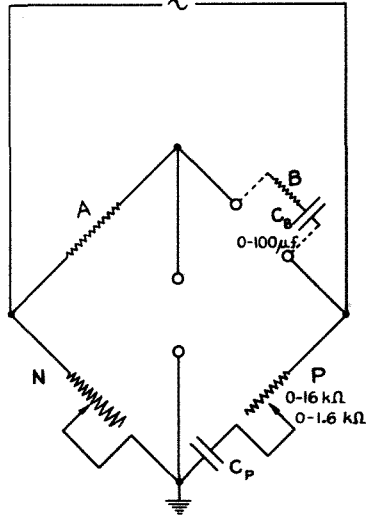

FIGURE 4. This circuit is recommended for the measurement of capacitance and dissipation factor (D) of condensers.

TABLE II

Unknown Capacitance C		Ratio Arms		Multiplying Factor for N Dial
Range for Greatest Accuracy	Total Range	P	A	
10 μf - 100 μf	1 μf - 100 μf	1 μf	100 Ω	10
1 μf - 10 μf	0.1 μf - 10 μf	1 μf	1000 Ω	1
0.1 μf - 1 μf	0.01 μf - 1 μf	1 μf	10,000 Ω	0.1
0.01 μf - 0.1 μf	1000 μf - 0.1 μf	0.01 μf	1000 Ω	0.01
1000 μf - 0.01 μf	100 μf - 0.01 μf	0.01 μf	10,000 Ω	0.001
100 μf - 1000 μf	10 μf - 1000 μf	1000 μf	10,000 Ω	0.0001

GENERAL RADIO COMPANY

ting of the added resistance in the P arm from zero to obtain a better minimum.

Alternately adjust the N dial and the added resistance in the P arm until the setting of each is unchanged on further adjustment of the other. The criterion of a good balance is the ability to detect the passage of the sliding contact over the individual wires if either dial is moved off balance. This condition should always be obtained for the N dial.

When D is greater than unity, the successive settings of the two arms will progress in value since the two balances are not independent. The number of successive settings which must be made before a good null balance is reached may be reduced by taking advantage of the orderly progression of the settings and slightly oversetting each one in the direction it will move the next time. When the true balance point is passed on the dial, the progress of the other dial in its next setting will be reversed.

The capacitance of the unknown condenser is given by the following relation

$$C_B = 1000 C_P \frac{N}{A} \text{ microfarads}$$

where C_P is expressed in uf, A in ohms and N is the reading of the N dial.

The factor $1000 \frac{C_P}{A}$, by which the reading of the N dial is multiplied to obtain C_P , is given in Table II.

The dissipation factor of the unknown condenser is given by the following relationship:

$$D_B = D_P = R_P \omega C_P$$

At a frequency of 1 kc,

$$D_B = 0.00628 R_P C_P$$

where R_P is expressed in ohms and C_P in microfarads.

Since dissipation factor, $\frac{R}{Z}$, is the ratio of resistance to reactance and power factor, $\frac{R}{Z}$, is the ratio of resistance to

impedance, they may be assumed to be equal for values up to 0.1.

The resistance of the unknown condenser is

$$R_B = \frac{AR_P}{1000N}$$

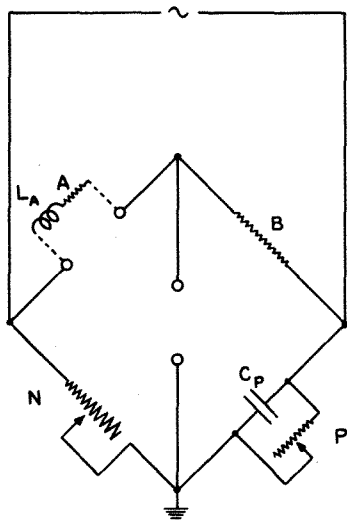

MAXWELL BRIDGE

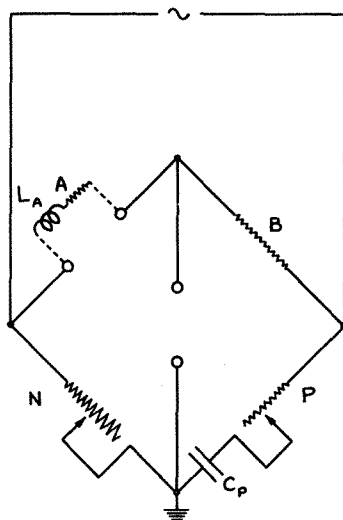

HAY BRIDGE

FIGURE 5. Either the Maxwell Bridge or the Hay Bridge is recommended for measurements of the inductance and energy factor (Q) of inductors.

GENERAL RADIO COMPANY

TABLE IV

Unknown Inductance A		Ratio Arms		Multiplying Factor
Range for Greatest Accuracy	Total Range	P	B	for N Dial
10 h - 100 h	1 h - 100 h	1 μ f	10,000 Ω	10
1 h - 10 h	100 mh - 10 h	1 μ f	1000 Ω	1
100 mh - 1 h	10 mh - 1 h	0.01 μ f	10,000 Ω	0.1
10 mh - 100 mh	1 mh - 100 mh	0.01 μ f	1000 Ω	0.01
1 mh - 10 mh	100 μ h - 10 mh	0.01 μ f	100 Ω	0.001
100 μ h - 1 mh	10 μ h - 1 mh	0.001 μ f	100 Ω	0.0001

INDUCTANCE Use one of the circuits of Figure 5. Select the proper values for the B and P arms from Table IV, above.

The scale below 0.1 on the N dial may be used to measure inductances below 10 μ h if the zero inductance of the bridge is first measured and subtracted from the total read on the dial.

Values for the resistor in the P arm corresponding to various values of Q_A will be found in Table V.

Q_A	C_P	R_P	
		Series—	Parallel
6-600	1 μ f	0.1-10	
0.06- 6	1 μ f	1-10,000
6-600	0.01 μ f	10-1000
0.06- 6	0.01 μ f	100-100,000

The resistor added for making the resistance balance is placed either in parallel or in series with the standard condenser. The parallel connection is Maxwell's bridge and may be used for all val-

ues of energy factor $Q = \frac{\omega L}{R}$, except that for large values the added resistance is too large to be obtainable on a variable resistor. The series connection is Hay's bridge and while it may also be used for all values of energy factor Q , the complicated correction term containing frequency becomes negligible only when Q is greater than 10. For best results, therefore, use Maxwell's bridge when A lies between 0 and 10, and Hay's bridge when Q is greater than 10.

Connect telephones to the DET terminals. Place GENERATOR switch on 1 KC position.

Place 1 KC GENERATOR IMPEDANCE switch on LOW if the impedance of the A or B arm is less than about 100 ohms; on HIGH if it is more than that value.

Proceed to balance the bridge as follows:

Turn the dial until minimum sound intensity is obtained. Increase the setting of the added resistance in the P arm from zero to obtain a better minimum when using

the Hay bridge; decrease for the Maxwell bridge.

Alternately adjust the N dial and the added resistance in the P arm until the setting of each is unchanged on further adjustment of the other. The criterion of a good balance is the ability to detect the passage of the sliding contact over the individual wires if either dial is moved off balance. This condition should always be obtained for the N dial.

When Q is less than about 0.1, the successive settings of the two arms will progress in value since the two balances are not independent. The number of successive settings which must be made before a good null balance is reached may be reduced by taking advantage of the orderly progression of the settings and slightly oversetting each one in the direction it will move the next time. When the true balance point is passed on one dial, the progress of the other dial in its next setting will be reversed.

The inductance of the unknown inductor is given by the relation

$$L_A = .001 \text{ BNC}_P \text{ henrys}$$

where B is expressed in ohms, N is the reading of the N dial, C_P is expressed in microfarads.

The energy factor $Q_A = \frac{L_A}{R_A}$ is the ratio

of the reactance of the inductor to its resistance. When the resistance is in parallel with the standard condenser,

$$Q_A = .00628 R_P C_P.$$

With the series connection,

$$Q_A = \frac{160}{R_P C_P}$$

where R_P is expressed in ohms, C_P is expressed in microfarads, and the frequency is 1000 cycles. Expressing R_P , C_P , N, and B in these units, the resistance of L_A is

$$R_A = \frac{1000 \text{ NB}}{R_P} \text{ for the parallel connection}$$

or

$$R_A = 0.040 \text{ NBR}_P C_P^2 \text{ for the series connection.}$$

GENERAL RADIO COMPANY

PART V ACCESSORIES AND SUGGESTIONS FOR INCREASING THE USEFULNESS OF THE BRIDGE

ACCESSORIES The General Radio Company manufactures convenient resistors and condensers fitted with plug-in terminals for use with the Type 625-A Bridge. The following two tables list the recommended sizes. (Note that the prices mentioned are subject to change without notice and for latest prices the current catalog and General Radio Experimenter should be consulted.)

Type 500 Resistors

Type	Resistance	Maximum Current	Price
500-AP	1 Ω	1 a	\$2.00
500-BP	10 Ω	300 ma	2.00
500-DP	100 Ω	100 ma	2.00
500-HP	1000 Ω	30 ma	2.00
500-JP	10,000 Ω	10 ma	2.00

Type 500 Condensers

Type	Capacitance	Price
505-FP	0.001 μ f	\$3.50
505-LP	0.01 μ f	4.00
505-QP	0.05 μ f	7.50

A 1- μ f condenser (Type 625-P1) is available. Price \$2.00.

RHEOSTAT Type 471 Rheostat-Potentiometers are available mounted in drawn steel cases, the same size as used for the Type 247-G Variable Air Condenser. Each has an etched dial graduated in 50 divisions. The total resistance has been adjusted to within 2-1/2% of the rated value. Price: \$8.50.

Type	Resistance
526-D	0-100 Ω
526-A	0-1000 Ω
526-B	0-10,000 Ω
526-C	0-100,000 Ω

EXTERNAL BATTERY An external battery may be used for direct-current measurements by connecting it to the EXTERNAL GENERATOR terminals and setting the GENERATOR switch at EXT., as mentioned on page 2. Care must be taken that the voltage applied to the bridge does not exceed the limits of safe operation for the bridge elements. The current through the N dial should not exceed 40 milliamperes.

EXTERNAL OSCILLATOR For measurements at frequencies other than 1000 cycles, an external oscillator may be used. The oscillator is connected to the EXTERNAL GENERATOR terminals and the GENERATOR switch is thrown to the EXT. ON position.

This greatly increases the usefulness of the bridge, allowing the characteristics of coils and condensers to be measured over a range of frequencies.

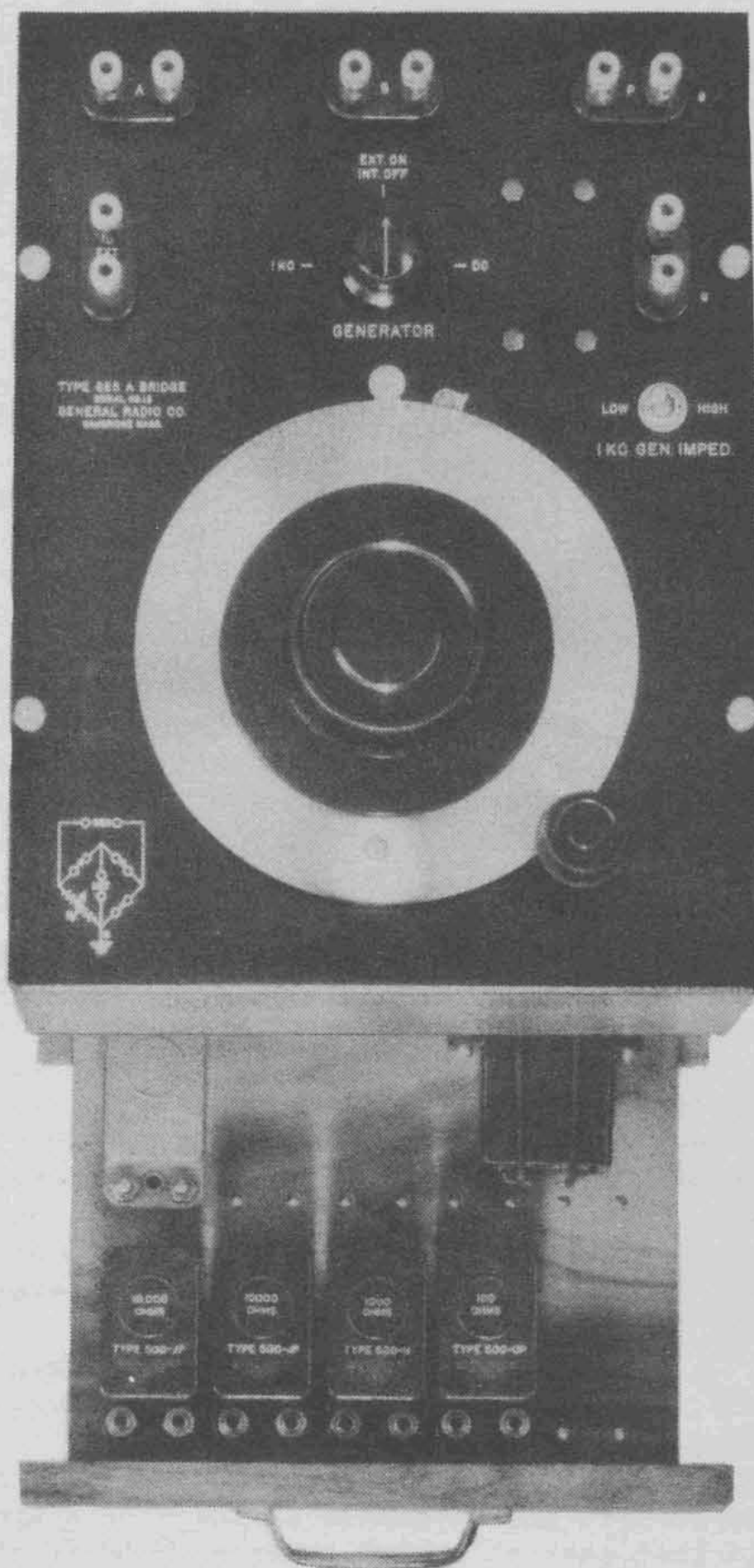

FIGURE 6. The drawer in the Type 625-A Bridge is for storing Type 500 Resistors, Type 505 Condenser, and the Type 625-P1 Condenser shown in the right rear corner.

GENERAL RADIO COMPANY

The expressions for dissipation factor and energy factor already given must, of course, be corrected for frequency.

VOLTAGE LIMITS An oscillator having a maximum output of 0.5 watt may be used under all conditions. When larger amounts of power are used, the following conditions apply.

GROUND CAPACITANCE ERRORS When an external oscillator is used, errors are introduced by its capacitance to ground. These errors are very small for inductance and capacitance readings and somewhat larger for dissipation factor and energy factor.

In a bridge with fixed ratio arms the errors in dissipation factor due to ground capacitances occurring either in the bridge itself or in an external power supply may be corrected by making the energy factor of the two ratio arms equal. This is accomplished by adding a parallel capacitance across that arm having the lower energy factor. When one ratio arm is continuously variable, as in this bridge, equality of energy factor may be obtained only for a particular setting.

If both output terminals of the oscillator have appreciable capacitance to ground, a portion of this will appear across each of the lower arms of the bridge (Figure 1b, 1c, and 1d). The division of capacitance between the two terminals may be determined by the effect of the use of such an oscillator on the measurement of a condenser which has been previously measured with the internal power supply.

When one terminal of the oscillator is grounded to its panel, almost the entire ground capacitance is associated with the grounded terminal, and will affect only one arm of the bridge. Under these conditions, representative values of ground capacitance are 30 μf for a battery-operated oscillator and 300 μf for an a-c operated oscillator, the increase representing the interwinding capacitance of the power-supply transformer.

SHIELDED TRANSFORMER The use of a shielded transformer between oscillator and bridge will suppress the effect of the ground capacitances of the oscillator, but will introduce similar effects of its own. For a shielded transformer most of the total ground capacitance is associated with one terminal of each winding; that terminal connected to the end of the winding next to the shield. A representative value of this capacitance is 100 μf . It is evident that a shielded transformer should be used with an alternating-current operated oscillator, but not with a battery-operated one.

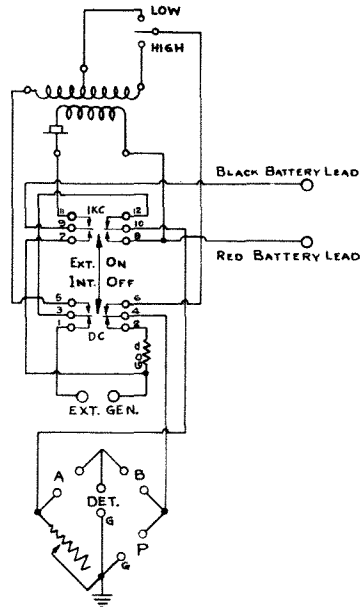

FIGURE 7. Wiring Diagram for Type 625-A Bridge. The switch is shown in its center position.

INCREASING SENSITIVITY The self-contained power supply consisting of four 1/5-volt dry cells for d/c measurements and a Type 572 Microphone Hummer for 1000-cycle a-c measurements is sufficient for the attainment of the accuracies previously mentioned. For a-c measurements, the telephones must be of good quality, equivalent in sensitivity and resistance to W. E. telephones, type 1002-C. For less sensitive telephones, for greater accuracy of setting, or for greater ease and convenience in obtaining a balance, an amplifier is very useful. The General Radio Type 514-A Amplifier* is suitable.

FILTERS The harmonics introduced by high-loss condensers, iron-core inductors, and non-linear circuit elements such as copper-oxide rectifiers may be eliminated by the use of low-pass filters. Band-pass filters, obtainable as separate

* Consult the General Radio Catalog for data.

GENERAL RADIO COMPANY

units or made up from low- and high-pass sections* will also eliminate the 60-cycle alternating-current hum induced in iron-core inductors and condensers of large physical dimensions. Type 330 Filter Sections** and Type 534 Band-Pass Filters* are available for these purposes.

* Robert F. Field, "Eliminating Harmonics in Bridge Measurements", General Radio Experiment, VI, December, 1931. Copies on request.

OTHER CIRCUITS In addition to those previously described, many other bridge circuits may be used with the Type 625-A Bridge. For a discussion of other types of circuits, see "A. C. Bridge Measurements" by B. Hague and published by Pitman.

** Consult the General Radio Catalog for data.

