

OPERATING INSTRUCTIONS



**TYPE 805-D**  
**STANDARD-SIGNAL**  
**GENERATOR**

805-D

G E N E R A L R A D I O C O M P A N Y

K



File Courtesy of GRWiki.org

OPERATING INSTRUCTIONS

TYPE 805-D  
STANDARD-SIGNAL  
GENERATOR

Form 0805-0100-K  
October, 1961

G E N E R A L R A D I O C O M P A N Y  
WEST CONCORD, MASSACHUSETTS, USA



File Courtesy of GRWiki.org

## TABLE OF CONTENTS

Introduction . . . . .	1
Section 1.0 Operating Controls and Procedure . . . . .	1
Section 2.0 Circuit and Constructional Details . . . . .	5
Section 3.0 Output Characteristics as a Function of Frequency . . . . .	6
Section 4.0 Routine Adjustments . . . . .	9
Service and Maintenance Notes . . . . .	11
Vacuum-Tube Data . . . . .	19
Transformer Voltage Data . . . . .	19
Parts List . . . . .	22
Wiring Diagram . . . . .	23

Copyright 1961 by General Radio Company  
West Concord, Massachusetts, USA



## SPECIFICATIONS

**Carrier Frequency Range:** 16 kilocycles to 50 megacycles, covered in seven direct-reading ranges, as follows: 16 to 50 kc, 50 to 160 kc, 160 to 500 kc, 0.5 to 1.6 Mc, 1.6 to 5.0 Mc, 5.0 to 16 Mc, 16 to 50 Mc. A spare range position is provided so that a special set of coils can be installed if desired.

**Frequency Calibration:** Each range is direct reading to an accuracy of  $\pm 1\%$  of the indicated frequency.

**Frequency Drift:** Not greater than  $\pm 0.1\%$  on any frequency range for a period of 5 hours' continuous operation.

**Incremental Frequency Dial:** A slow-motion vernier drive dial is provided, by means of which frequency increments as small as 0.01% may be obtained.

**Output Voltage Range:** Continuously adjustable from 0.1 microvolt to 2 volts. The output voltage (at the termination of the 75-ohm output cable) is indicated by a panel meter and seven-point multiplier.

**Output System:** The output impedance at the panel jack is 75 ohms, resistive. A 75-ohm output cable is provided, together with a termination unit that furnishes constant output impedances of 37.5, 7.1, and 0.75 ohms. The calibration of the panel voltmeter-multiplier combination is in terms of the actual voltage across the 37.5-ohm output. When the 7.1- and 0.75-ohm positions are used, the indicated output voltage must be divided by 10 and 100, respectively. A standard dummy-antenna output is also available at the termination unit.

The alternate Type 805-P2 Termination Unit will provide an effective output impedance of 50 ohms. This will permit the use of several 50-ohm accessory units, as well as a direct connection to 50-ohm systems. Convenient adaptor units are available to convert the Type 874 output connector to other commonly used types.

**Output Voltage Accuracy:** For multiplier settings below 1 volt the maximum error in output voltage is the sum of the attenuator and voltmeter errors listed below.

**Maximum Voltmeter Error:**  $\pm 5\%$  of indicated reading up to 25 megacycles. Above 25 megacycles, an additional frequency error occurs, amounting to a total of  $\pm 7\%$  at 50 megacycles. At 1% full scale and 50 Mc, there is also a transit-time error of  $-5\%$  in the voltmeter tube.

**Maximum Attenuator Error:**

- Below 3 Mc,  $\pm (3\% + 0.1 \text{ microvolt})$
- 3 to 10 Mc,  $\pm (5\% + 0.2 \text{ microvolt})$
- 10 to 30 Mc,  $\pm (10\% + 0.4 \text{ microvolt})$
- 30 to 50 Mc,  $\pm (15\% + 0.8 \text{ microvolt})$

There is no attenuator error for the 1-volt multiplier setting.

**Modulation:** Continuously variable from 0 to 100%. The percentage of modulation is indicated by a panel

meter to an accuracy of  $\pm 10\%$  of the meter reading up to 80%, for carrier frequencies below 16 Mc;  $\pm 15\%$  for higher carrier frequencies.

Internal modulation is available at 400 cycles and 1000 cycles, accurate in frequency within  $\pm 5\%$ .

The generator can be modulated by an external oscillator. Approximately 10 volts across 500,000 ohms are required for 80% modulation. The over-all modulation characteristic is as follows:

Carrier Frequency	Audio Range	Level
0.5—50 Mc	50cps—15,000cps	$\pm 1 \text{ db}$
0.1—0.5 Mc	50cps—10,000cps	$\pm 1.5 \text{ db}$
16—100 kc	50cps—10% of Carrier Frequency	$\pm 1.5 \text{ db}$

**Frequency Modulation:** On the highest carrier frequency range the frequency modulation is about 0.05% for 100% modulation, and 0.02% for 30% modulation. At lower carrier frequencies the frequency modulation is less than these percentages.

Above 20 Mc for applications where incidental fm must be negligible or for wideband (video) modulation, the TYPE 1000-P6 Crystal Diode Modulator should be used.

**Distortion and Noise Level:** The envelope distortion at a modulation level of 80% is less than 5% at 1 Mc carrier frequency. Carrier noise level is at least 40 db below 80% modulation.

**Leakage:** The magnetic induction leakage is less than 5 microvolts per meter at a distance of 2 feet from the generator. The 3-foot output cable permits the receiver under test to be kept beyond this limit. Radiation fields are negligible.

**Power Supply:** The instrument operates from any 40 to 60 cycle, 115-volt (or 230-volt) line. An electronic voltage regulator compensates for line voltage fluctuations from 105 to 125 volts (or from 210 to 250 volts). A maximum input power of 150 watts is required.

**Tubes:** Supplied with instrument.

2 — 1614	1 — 0D3/VR150
3 — 6L6GC	2 — 6AL5
2 — 12AX7	1 — Amperite 3-4

**Other Accessories Available:** TYPE 805-P2 Termination Unit, TYPE 1000-P Accessories and TYPE 1750-A Sweep Drive.

**Mounting:** The panel is finished in gray crackle and the cabinet has a gray wrinkle finish.

**Dimensions:** Width 33, height 16, depth 13 inches (840 by 410 by 330 mm), over-all.

**Net Weight:** 118 pounds (54 kg).

THIS APPARATUS USES INVENTIONS OF UNITED STATES PATENTS LICENSED BY RADIO CORPORATION OF AMERICA PATENT NUMBERS SUPPLIED UPON REQUEST NOT LICENSED FOR DOMESTIC FIXED-STATION, PUBLIC SERVICE COMMUNICATION FOR HIRE OR TOLL

U.S. Patent No. 2,548,457



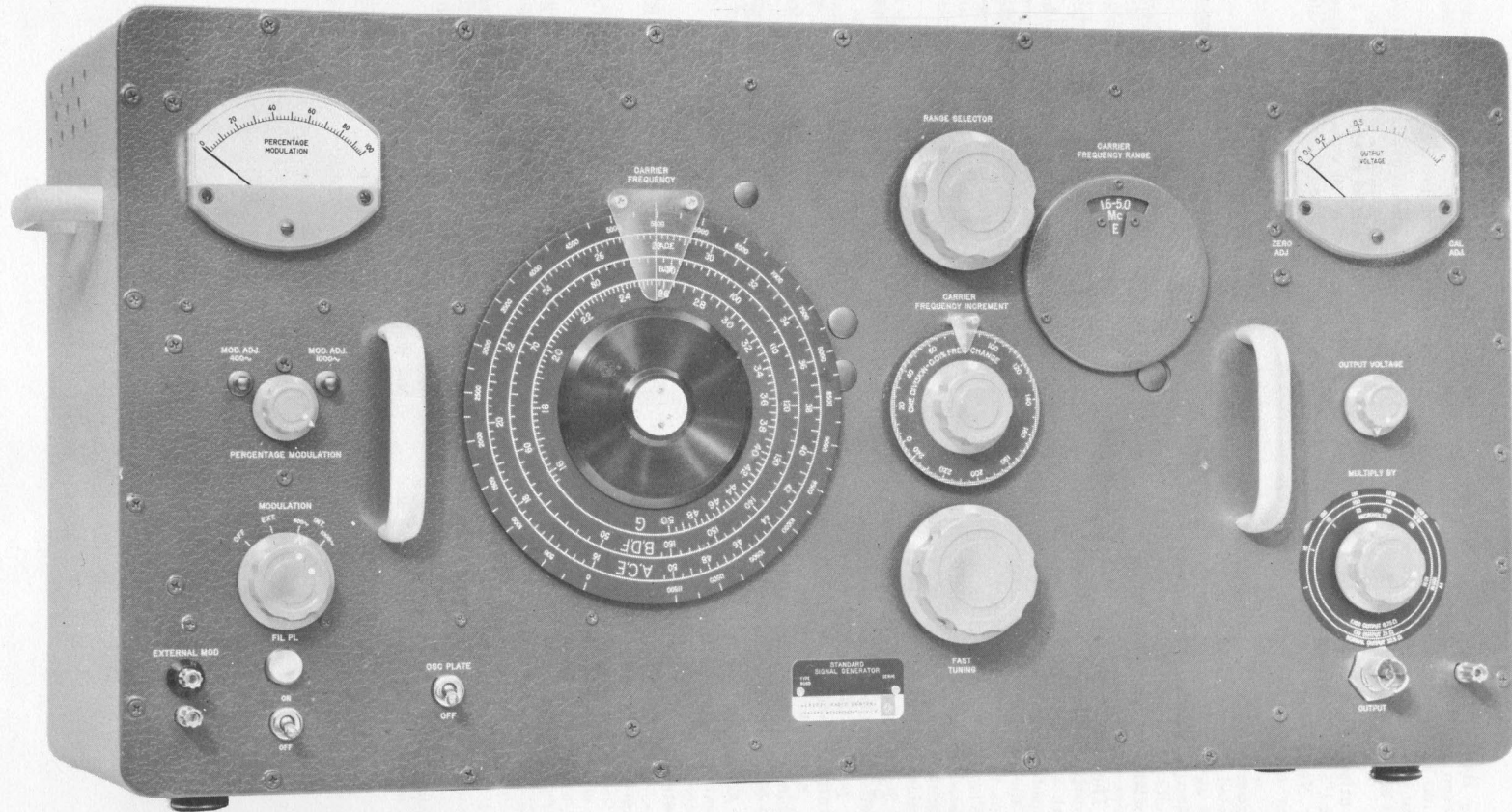

OPERATING INSTRUCTIONS

TYPE 805-D STANDARD-SIGNAL GENERATOR

INTRODUCTION

The Type 805-D Standard-Signal Generator is a precision laboratory instrument designed primarily for the rapid and accurate testing of radio receivers. Its speed and simplicity of operation make it very useful for production testing, while its accuracy, wide frequency range, high output voltage, and high amplitude modulation with low frequency modulation make it a desirable instrument for laboratories engaged in research

and design on radio receivers and allied apparatus.

Functionally this instrument consists of (1) a carrier-frequency oscillator, (2) a tuned radio-frequency amplifier, (3) a resistive output attenuator and a voltmeter to read the output level, (4) a modulation oscillator (400 cycles and 1000 cycles) with a voltmeter for reading percentage modulation, and (5) a well-regulated power supply.

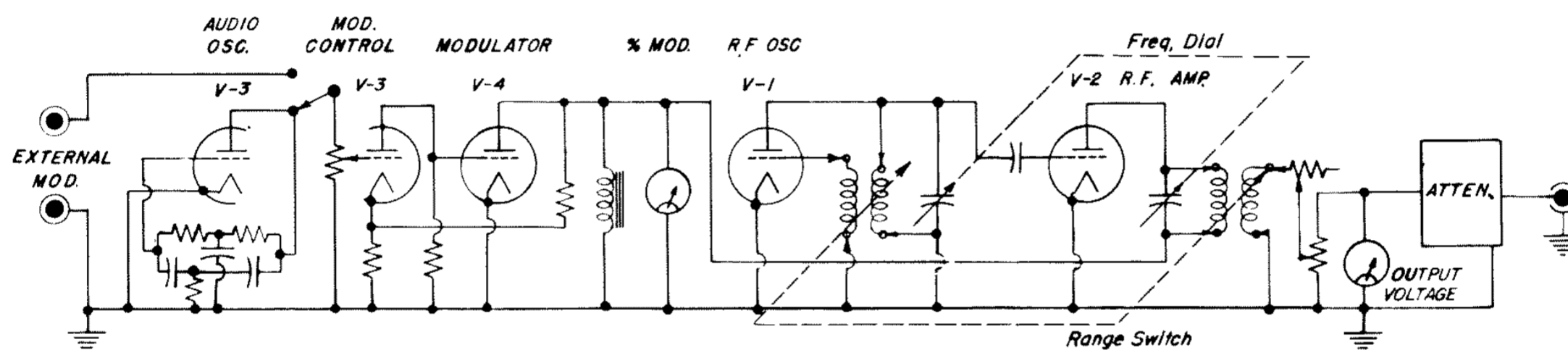

Figure 1. Elementary Schematic Diagram.

SECTION 1.0

OPERATING CONTROLS AND PROCEDURE

1.1 POWER SUPPLY

**1.11 Voltage and Frequency:** Be sure that the voltage and frequency of the power line are the same as those engraved on the plate at the power line socket. The power transformer is wound for both 115 and 230 volts. Conversion is made by changing transformer connections (see paragraph 2.6).

**1.12 Switches:** The ON-OFF switch controls the entire power supply. The OSC PLATE switch turns off the generator output without materially altering the heat generated inside the cabinet, and hence allows the generator output to be turned off for short periods, or reduced quickly to zero for check purposes, without an attendant drift in frequency when it is again turned on.

1.2 FREQUENCY

**1.21 Range Selector:** The frequency range is 16 kilocycles to 50 megacycles. This is covered in a coil-changing mechanism that can be rotated continuously in either direction. The coil ranges are selected by the knob marked RANGE SELECTOR, and the range in use is indicated by the dial marked CARRIER FREQUENCY RANGE. There is also a blank position in which a special set of coils may be placed if desired. Within each band, the frequency is determined by the setting of air condensers, whose plates are shaped to give a logarithmic variation of frequency with angle of dial rotation. Equal angles of rotation correspond to equal percentage increments in frequency.

## GENERAL RADIO COMPANY

**1.22 Carrier Frequency:** The operating frequency is indicated by the large dial marked CARRIER FREQUENCY. The knob marked FAST TUNING may be used between widely separated points on the scale. Frequency scales on the main dial are accurate to better than 1%.

**1.23 Frequency Increments:** Dial readings can be easily converted to cycles per second for selectivity measurements.

**1.24 Frequency Stability:** The carrier frequency oscillator has been designed for small frequency drift, without the use of compensators. When coil ranges are switched, an initial frequency drift of approximately  $-.05\%$ , or less, will be observed. This will occur in the first twenty minutes (approximately) of operation on the coil range immediately switched into position. After this point has been reached, the drift will be in the opposite direction but considerably less in magnitude. The drift rate will be about  $+.02\%$  per hour, or less, for the next  $2\frac{1}{2}$  hours, and will gradually decrease.

### 1.3 OUTPUT

**1.31 Attenuator and Meter:** The output is continuously variable from 0.1 microvolt to 2 volts and is determined by the setting of the attenuator multiplier and the meter reading. The voltage applied to the OUTPUT VOLTAGE meter is adjusted by means of the OUTPUT VOLTAGE knob below it on the panel.

#### Type 805-P1

The voltage between the terminals marked G and NORMAL on the Type 805-P1 Termination Unit is given by the product of the meter reading and the setting of the MULTIPLY BY switch. The NORMAL output impedance is 37.5 ohms, but output may be had at 7.1 ohms and 0.75 ohm by setting the knob on the termination unit to 1:10 and 1:100 respectively. In these cases the output voltage must be further multiplied by 0.1 and 0.01, respectively. The lower impedance settings are not recommended for frequencies above 10 Mc, where accurate results are desired.

#### Type 805-P2

An alternate Type 805-P2, 50-ohm Termination Unit is available. This can be used interchangeably with the Type 805-P1 Termination Unit. Disconnect the cable at the panel connector.

The Type 805-P2 provides an effective output impedance of 50 ohms at its output terminals. The OUTPUT VOLTAGE meter thus indicates directly in volts-behind-50-ohms.

The above system is intended for use with 50-ohm systems and with other available accessories.

**1.32 Dummy Antenna: Type 805-P1:** A standard dummy antenna is placed in series with the output voltage when the output is taken from the terminals marked G and DUMMY. The circuit is that of the standard dummy antenna, as specified by the I.R.E. Standards.

**Type 805-P2:** When this termination is used, the Type 1000-P1 may be used with the Type 1000-P4 Dummy Antenna to provide an alternate system.

**1.33 Caution:** Care must be taken to prevent the introduction of voltages back into the termination unit from the circuit under test. Currents greater than 50 milliamperes may damage or burn out the resistance units. Always connect the grounded lead first to any grounded circuits, or to receivers having capacitance to the ac power line. This will prevent heavy capacitive discharge currents from getting into the attenuator resistors.

**1.34 Frequency Characteristic:** Variations in output voltage and output impedance as a function of frequency are discussed in Section 3.

**1.35 Output Meter Switch:** A switch (S-4), operated automatically by the RANGE SELECTOR, changes the response characteristics of this meter so that it is not affected by the presence of modulation on the carrier. This enables the output voltage to be read simultaneously with the modulation percentage, for carrier frequencies above 160 kc. With the RANGE SELECTOR switch in the A or B position, the output meter will indicate the carrier amplitude correctly, provided the modulation does not exceed 1000 cycles. For modulation frequencies above this value, the output meter will tend to read high. Under these conditions, it is necessary to turn off the modulation when reading the OUTPUT meter.

### 1.4 MODULATION

**1.41 Controls:** The PERCENTAGE MODULATION is adjusted and indicated by the knob and meter that are so marked. The modulation frequency is controlled by the switch marked MODULATION, which selects either 400 or 1000 cycles from an internal audio oscillator, or, in the EXT. position, selects a modulating voltage from any external source connected to the terminals marked EXTERNAL MOD.

**1.42 Meter Accuracy:** At carrier frequencies above 500 kc, the accuracy of indication of modulation percentage is  $\pm 10\%$  for modulation frequencies between

# GENERAL RADIO COMPANY

50 and 15,000 cycles, except on the G carrier range, where the accuracy is  $\pm 15\%$ .

**1.43 Residual Meter Indication:** On the A, B, or C ranges a small deflection of this meter may be noted, with the modulation turned off. This is caused by the carrier frequency, but will not impair the readings of the meter at modulation levels above 25%.

**1.44 Envelope Waveform:** The waveform of the radio frequency envelope is low in distortion, over the entire range of the instrument. Carrier frequency output is essentially sinusoidal on all ranges. Modulation distortion is limited to approximately 4% when the internal modulating oscillator is used, for levels as high as 80% modulation, rising to about 10% at 100% modulation. With an external modulating source, the distortion will depend upon the waveform of the source, and upon the frequency. In general, the distortion tends to increase at the higher modulating frequencies and at the highest modulation percentages. However, it is possible when an external oscillator of low harmonic content is used, to obtain 80% modulation at 15,000 cycles with low envelope distortion.

## 1.5 CONNECTIONS TO RECEIVER

**1.51 Terminations: Type 805-P1:** Connections to receiver should be made by the cable and termination unit provided. The cable impedance is 75 ohms and is provided with a 75-ohm load, thus providing a net output impedance of 37.5 ohms. This impedance remains essentially constant up to 10 Mc, but changes slightly at higher frequencies owing to the presence of residual reactances in the attenuator and termination unit. This variation is shown in Section 3.

### Type 805-P2

This cable and termination assembly should be used with a receiver input impedance of 50 ohms. The output impedance of this unit will match 50-ohm systems up to about 40 Mc. Residual reactances lower the impedance above 40 Mc, as shown in Section 3.

This termination unit is provided with a standard GR Type 874 output connector. A complete line of adaptors is available to connect this connector to other commonly used types.

**1.52 Leads:** The leads between the termination unit and the receiver binding posts should be short and direct. It is preferable to plug the termination unit into the receiver, if convenient.

## 1.6 USE WITH LOOP RECEIVER

Receivers employing loop antenna pickup can be tested using either of the two standard methods, as outlined in the Standards on Radio Receivers, 1948, of the Institute of Radio Engineers.

### Type 805-P1

The low-impedance-output tap (0.75 ohms) is recommended for use with the method that uses a voltage inserted in series with the antenna loop. To avoid detuning the loop, the signal generator should be connected in series with the grounded, or low r-f potential, end of the loop circuit. *CAUTION:* This method is not recommended for use with the AC-DC type of receiver where one side of the line is connected directly to the receiver chassis. There is considerable shock hazard if the signal generator is operated ungrounded; and there is a danger of introducing sufficient voltage into the attenuator to damage the precision resistances.

### Type 805-P2

A second method involves a transmitting loop antenna inductively coupled to the receiver loop antenna. With such an arrangement, there is no direct connection to the receiver. This offers considerable advantage over the direct connection method, in both convenience and freedom from shock, and avoids possible attenuator damage. It is recommended for use with AC-DC types of receivers.  $\Gamma$

**TYPE 1000-P10 TEST LOOP.** (See Figure 2.) With this test loop, receivers with loop antennas can be tested by several methods recommended by the Institute of Radio Engineers.<sup>1</sup> The three-turn loop is

<sup>1</sup>"Method of Testing Receivers Employing Ferrite Core Loop Antennas", *PROCEEDINGS OF THE INSTITUTE OF RADIO ENGINEERS*, September 1955.

"Measurement of Loop-Antenna Receivers", W. O. Swinyard, *PROCEEDINGS OF THE INSTITUTE OF RADIO ENGINEERS*, July 1941.

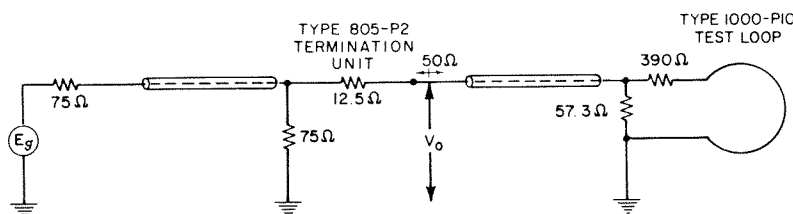

Figure 2. Diagram of Type 1000-P10 Test Loop.



## GENERAL RADIO COMPANY

enclosed in aluminum tubing for electrostatic shielding. With a 50-ohm generator (Type 805-D with Type 805-P2), the field strength in volts per meter, at a distance of 19 inches from the loop, equals 1/10 the signal-generator output in volts. Or, the electric field intensity  $\epsilon$ , in microvolts,  $s$  inches away from the test loop is

$$\epsilon = \frac{712.5}{s^3} V_0$$

where  $V_0$  is the open-circuit output voltage at the output terminals of the Type 805-P2, as indicated on the panel of the Type 805-D. Full details on this application are supplied with the Type 1000-P10 Test Loop.

When using the generator for measurements in the standard broadcast band of frequencies, best results will be obtained when the generator is operated with a good electrical ground. A convenient grounding terminal is located near the OUTPUT terminals of the attenuator. On the highest carrier frequency range, grounding the generator will not make any significant difference in the results obtained.

### 1.7 USE FOR VIDEO AMPLIFIER TESTING

While the generator was not specifically designed for this use, it can be quite useful in making amplitude versus frequency tests of video amplifiers. Certain precautions must be observed if consistently accurate results are to be obtained.

The OUTPUT VOLTAGE meter of the instrument employs a half-wave diode. The loading effect of this diode introduces a small amount of r-f waveform distortion in the form of peak clipping. This is not serious for radio-receiver testing, but can result in errors of some consequence when the response characteristics of video amplifiers are being measured. This is especially true when an external voltmeter of the peak-response type is used to monitor the output of the amplifier under test. If the video amplifier consists of an odd number of stages, and consequently results in a 180 degree phase reversal between input and output, then the waveform asymmetry will cause a difference in reading between the panel voltmeter of the 805-D and the external monitoring voltmeter.

To avoid this difficulty, the voltmeter used to monitor the output of the amplifier under test should operate with the same polarity as the voltmeter in the signal generator. For an amplifier with an odd number of stages, this would require inverting the monitoring voltmeter. If the amplifier consists of an even number of stages, and does not introduce a 180 degree phase shift, no trouble should be encountered. If these precautions are observed, a Type 1800-B Vacuum-Tube Voltmeter, which is a half-wave peak-response instrument, can be used as the external monitoring voltmeter. The measurements will be within an accuracy consistent with the specifications for the Type 805-D Standard-Signal Generator.

## SECTION 2.0 CIRCUIT AND CONSTRUCTIONAL DETAILS

### 2.1 WIRING DIAGRAM

Figure 15 is a complete wiring diagram.

### 2.2 RADIO-FREQUENCY SECTION

The master oscillator and r-f amplifier are nearly identical in construction and are mounted in the two-section shielded box in the center of the instrument. Viewed from the panel, the oscillator is on the left and the amplifier on the right. The oscillator tube, V-1, and the amplifier, V-2, are both Type 1614. Figure 3 shows the general arrangement.

The logarithmic tuning condensers have heavy cast-aluminum frames, with ceramic insulation for both the rotor and the stator. They are coupled together and to the main and increment dials by carefully machined cast-brass gears, which are spring compensated so as to have no appreciable backlash. The coils are mounted on discs in such a way as to keep the length of leads to a minimum. The coil discs are coupled together to a detent mechanism by the same type of gears used in the tuning condenser gear train.

### 2.3 OUTPUT SYSTEM

The output voltmeter is at the right-hand end of the instrument. An Amperite 3-4 (V-10) is mounted on the modulation shelf. This is connected in series with the heaters of the output- and modulation-voltmeter tubes to reduce the effect of line voltage fluctuations. The output voltmeter tube (V-9) is a Type 6AL5 tube and is located inside the attenuator multiplier shield. One section of the 6AL5 double diode (V-11) is used to provide a bucking voltage to balance the initial diode current of the 6AL5 tube (V-9) to zero. The output potentiometer is a form of "L" pad. The multiplier is a ladder network. The attenuator is designed for operation up to 50 megacycles.

### 2.4 MODULATOR

The modulator section is on the upper shelf at the left end of the instrument. Viewed from the panel, the three tubes on this shelf are, from left to right, a 12AX7 duplex triode (V-3), a 6L6GC beam power amplifier (V-4), and a 6AL5 rectifier (V-11).

One half of the 12AX7 (V-3) is used as the internal audio oscillator to supply frequencies at either 400 or

1000 cycles from a parallel "T" type, resistance-capacitance oscillator circuit. The other half is a pre-amplifier for both internal and external modulation. The 6L6GC (V-4) is the modulating power-amplifier tube. Modulation is applied to the plate and screen of the r-f amplifier (Type 1614) so as to minimize frequency modulation at high percentages of amplitude modulation. One half of the 6AL5 tube (V-11) is in the circuit of the modulation vacuum-tube voltmeter.

### 2.5 PANEL METERS

Individual panel meters are provided for simultaneously indicating the amplitude of the radio-frequency output voltage and the modulation percentage.

**2.51 Modulation Meter:** An average-response, diode rectifier (6AL5, V-11) is used to measure the amplitude of the audio-frequency voltage applied to the modulator stage (1614, V-2). A d-c microammeter (M-2) measures the current in the diode circuit and is calibrated directly in percentage modulation.

The calibration of this meter, for each range, is effected by resistors located on the oscillator turret gear and can be reached through a snap button on the panel.

**2.52 Output Meter:** A diode rectifier (6AL5, V-9) is used to measure the carrier frequency amplitude at the input to the attenuator. The meter scale is calibrated in terms of the r-m-s output voltage appearing at the end of the cable and indicates the voltage across the NORMAL terminals.

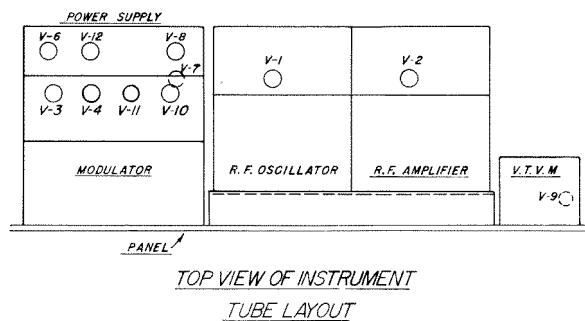

Figure 3. Location of Tubes.

### 2.6 POWER SUPPLY

The power supply is mounted on the lower shelf at the left end of the instrument. This shelf supports five tubes, which, viewed from the panel and from left to

# GENERAL RADIO COMPANY

Figure 4. Identification of terminals on terminal blocks of r-f inductors.

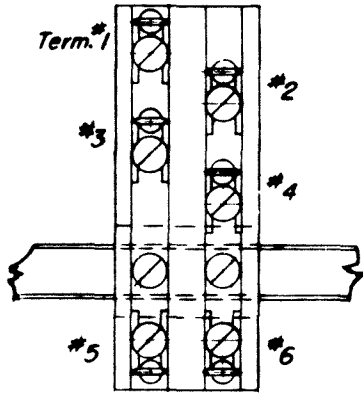

right, are two Type 6L6GC tubes (V-6 and V-12), 4 Type 1N3196 Rectifiers (V-5), a Type VR-150-30 Voltage Regulator (V-8), and in front of this, under the upper shelf, a Type 12AX7 (V-7). The 6L6GC's, the VR-150-30, and the 12AX7 (V-6, V-12, V-8 and V-7, respectively) are in the electronic voltage regulator circuit. This regulator will take care of normal line voltage fluctuations between 105 and 125 volts, the

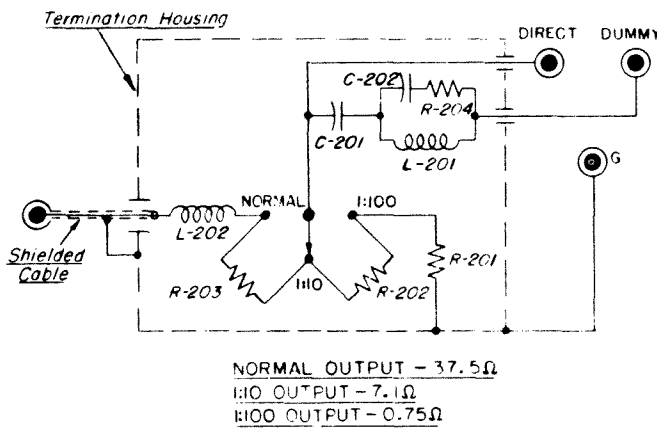

Figure 5a. Wiring Diagram of Type 805-P1 Termination Unit.

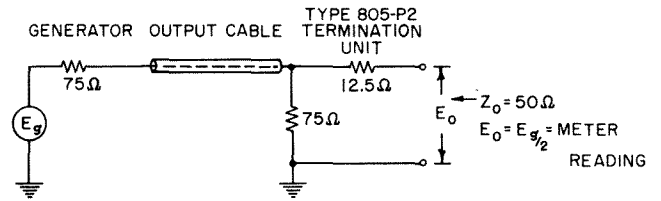

Figure 5b. Wiring Diagram of Type 805-P2, 50-ohm Termination Unit.

line voltage for which the generator is normally connected. However, the connections to the power transformer may be changed so as to make the regulator work from 210 to 250 line volts.

The power transformer is mounted on the lower left end shelf, and the primary taps (numbered 1, 2, 3 and 4) are on a black bakelite strip on the upper rear of this transformer. When the instrument is out of the cabinet these terminals are accessible from the rear.

For 105- to 125-volt operation, connect jumpers from terminal No. 1 to terminal No. 3 and from terminal No. 2 to terminal No. 4.

For 210- to 250-volt operation, connect a jumper from terminal No. 2 to terminal No. 3 (only).

In either case, the white wires with green and yellow tracers connect to terminals No. 1 and No. 3.

When the generator is shipped, the small plate at the power inlet indicates the line voltage for which the transformer is connected. If connections are changed, reverse this plate.

## 2.7 CAUTION

If it is necessary to operate the instrument outside of its cabinet, an extension cord should be used to connect the instrument to the power plug located inside the cabinet. Unless this is done the instrument will not be protected by the line fuses.

## SECTION 3.0

### OUTPUT CHARACTERISTICS AS A FUNCTION OF FREQUENCY

#### 3.1 VOLTAGE

Output voltage errors arise from several sources, namely

- (1) Errors in the output voltmeter.
- (2) Errors resulting from residual reactances in the termination unit.

- (3) Errors in attenuation ratio resulting from resistance and reactance variations between attenuation steps.

**3.11 Voltmeter Errors:** The plot of Figure 6 shows the maximum error to be expected on the 1-volt multiplier when all sources of error are additive. The error

# GENERAL RADIO COMPANY

(RIGHT)

Figure 6. Maximum voltmeter error as a function of frequency when all component errors are additive. This is the maximum error in output voltage at the 1v multiplier position.

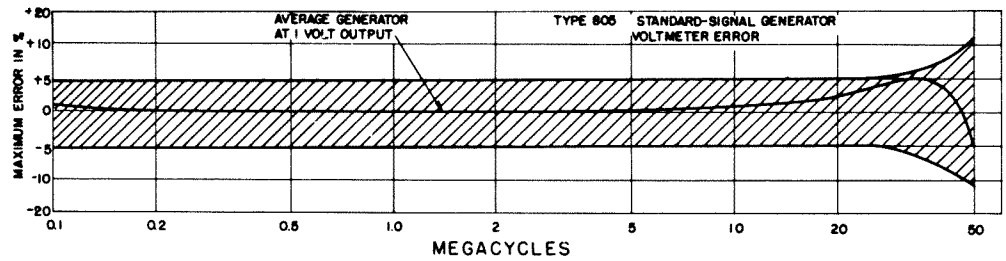

below 25 Mc is entirely residual calibration error, including such factors as the normal uncertainty of setting to the 2-volt line, and, the effect of waveform at low frequencies. The use of a logarithmic scale results in a substantially uniform accuracy over a complete decade. This is  $\pm 5\%$  of the indicated reading.

Above 25 Mc, a frequency error in voltmeter response amounting to  $\pm 6\%$  at 50 Mc is added; and, at 1/10 full scale, a further transit time error in the voltmeter tube of  $-5\%$ .

**3.12 Type 805-P1 Termination Unit:** Shunt capacitance in the termination unit causes a gradual dropping off in voltage as the frequency is increased. This error is compensated by a series loading coil located inside the termination unit, and the net error is included in the figures given above in paragraph 3.11.

**3.13 Attenuator Error:** A maximum variation of  $\pm 1\%$  occurs in the adjustment of individual resistors in the attenuator. Variations in the reactance of these resistors, however, is more important and accounts for most of the frequency error, which rises to  $\pm 15\%$  at 50 Mc. Figure 7 shows this maximum error as a function of frequency.

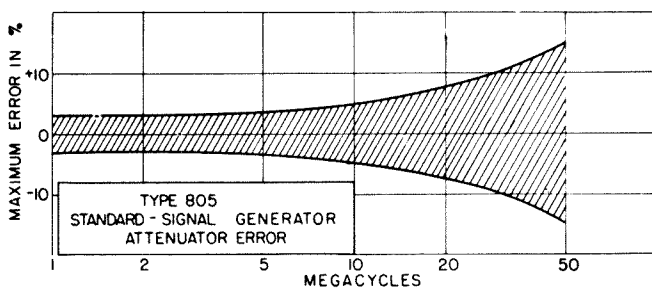

Figure 7. Maximum attenuator error as a function of frequency.

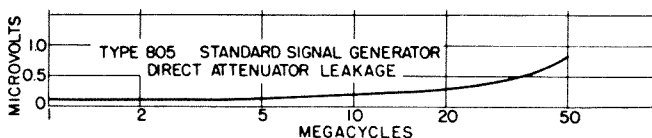

Figure 8. Direct attenuator leakage as a function of frequency. This is significant only on the lowest multiplier position.

**3.14 Total Error:** The total possible error is the sum of the voltmeter and attenuator errors given above. Obviously, some of these errors will tend to cancel, and the actual error may be less than is indicated by these figures. In Figure 6, the average total error for 10 typical generators is shown by the curve marked "Average Generator at 1-Volt Output."

**3.15 Direct Leakage in Attenuator:** Direct leakage, one source of which is capacitance across the attenuator from input to output, results in a fixed error which is effective only on the lowest multiplier step, and increases with frequency. This is shown in Fig. 8.

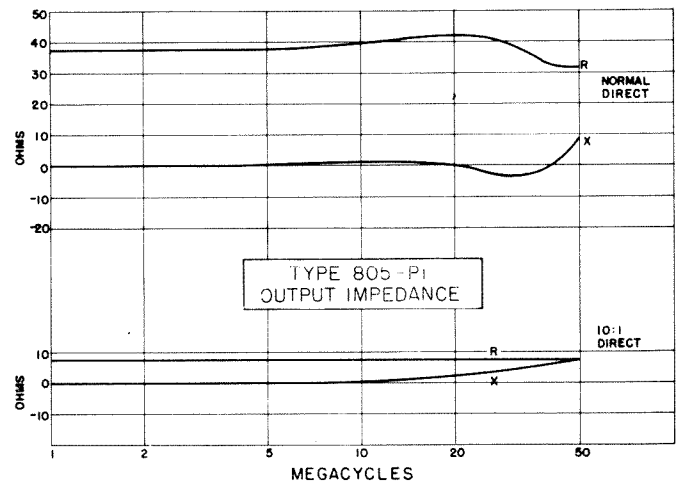
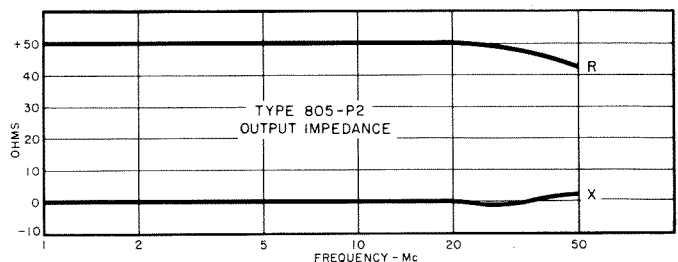

Figure 9. Frequency characteristic of output impedance at termination units. (a) Type 805-P1. (b) Type 805-P2.



### 3.2 OUTPUT IMPEDANCE

#### Type 805-P1

3.21 Residual inductance in the attenuator and shunt capacitance in the termination unit switch cause the output impedance at the termination unit to deviate at high frequencies from its low-frequency resistive value of 37.5 ohms. The output impedance as a function of frequency at the DIRECT output plug is given in Figure 9 for both the NORMAL and 10:1 positions of the switch. For the 100:1 position, the impedance varies in essentially the same way, but the resistance is reduced to 0.75Ω.

3.22 Consequently, the open-circuit voltage at the termination unit is seen in series with the impedance indicated by these curves. For load impedances that are not high compared to this generator impedance, load voltage will differ from this open-circuit value. If the load impedance is known, the voltage division can be calculated. The load impedance can be measured on a Type 1606-A Radio-Frequency Bridge.

3.23 The reactive component of output impedance for the 10:1 position rises to a value greater than the resistive component at high frequencies. *This position is not intended for use at frequencies above 10 megacycles.*

3.24 Type 805-P2: This termination unit has lower residual reactances than the Type 805-P1 and con-

sequently it maintains a more uniform output impedance characteristic, as shown in Figure 9b.

### 3.3 GENERATOR AND CABLE IMPEDANCE

3.31 If neither termination unit is used, higher open-circuit output voltages can be obtained because the 2:1 drop in voltage caused by the cable termination is avoided. If the attenuator had no reactance, the impedance at the open end of the cable would be 75 ohms resistive, and the open-circuit output voltage would be twice that indicated by the generator output calibration, which is correct for a terminated cable.

3.32 With the termination unit removed and an equivalent cable of the same length and impedance substituted, the impedance characteristic is that shown in Figure 10, and the open-circuit voltage is twice that indicated by the output meter and attenuator.

3.33 The deviation in impedance from the normal resistive value of 75 ohms is caused by inductance in the attenuator, whose characteristic is shown in Figure 11. Since the attenuator and cable system is series resonant at approximately 20 megacycles, the sign of the reactance seen at the open end of the cable is reversed at higher frequencies, as shown in Figure 10.

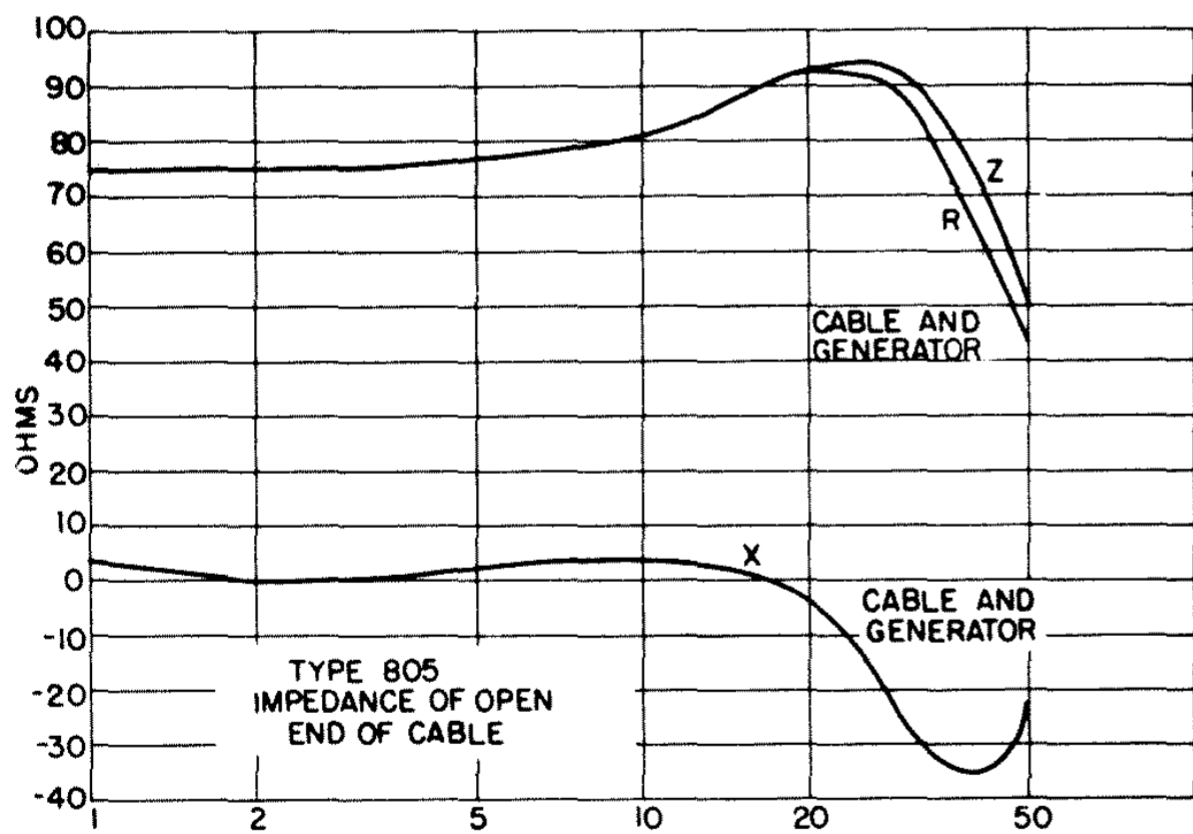

Figure 10. Output impedance at open end of cable.

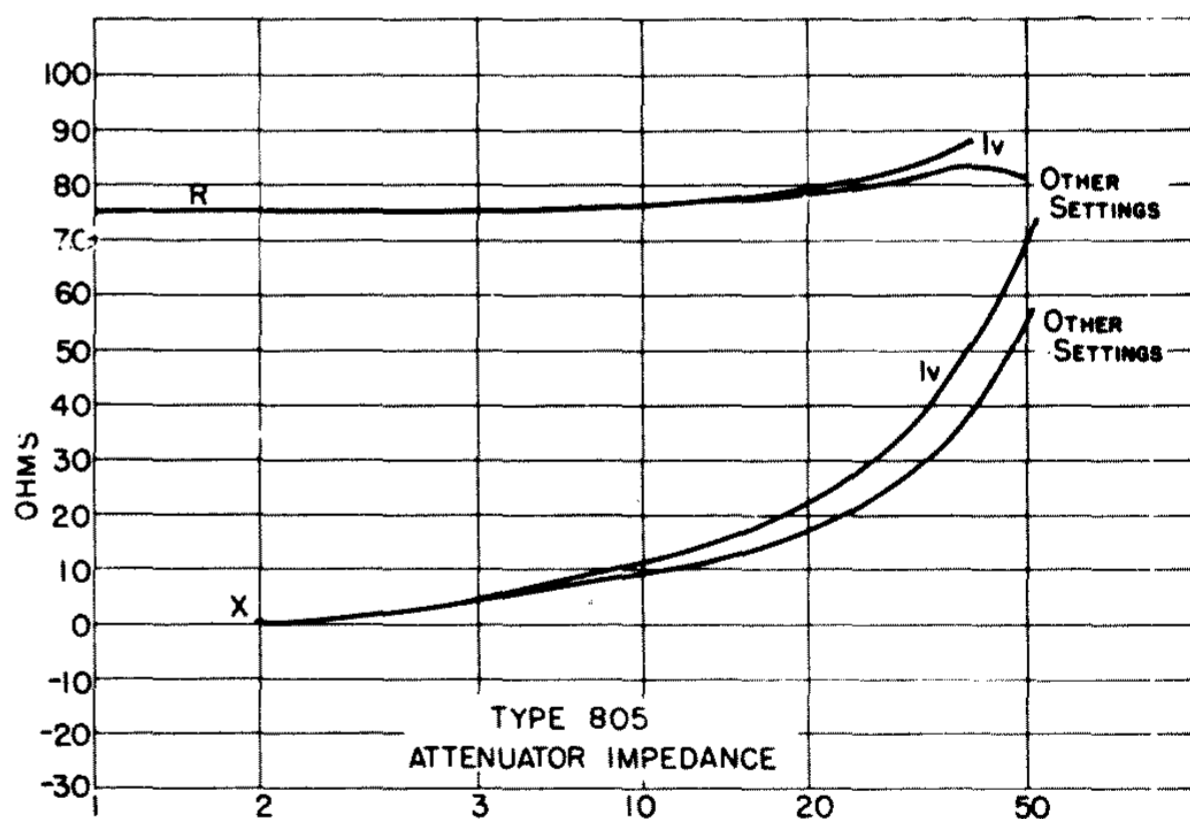

Figure 11. Attenuator impedance as a function of frequency.

# GENERAL RADIO COMPANY

## SECTION 4.0

### ROUTINE ADJUSTMENTS

#### 4.1 PANEL ADJUSTMENTS

There are five adjustments under snap buttons, which may be readjusted from time to time as it becomes necessary. They are as follows:

**4.11 Internal Modulation Frequency Adjustments:** Separate adjustments marked MOD. ADJ. 400 and MOD. ADJ. 1000 are provided for the 400- and 1000-cycle modulating frequencies. These are intended to be adjusted for minimum harmonic content, and should be set so that the oscillator just oscillates stably.

**4.12 Zero Adjustments on Output Meter:** With the instrument turned off, this voltmeter should be set at zero by means of the manual adjustment on the meter itself. When the instrument is operating and fully warmed up, the meter should be reset to zero, as necessary, by means of the control marked ZERO ADJ. This adjustment should be made with the PL. VOLTS switch in the OFF position. (The OUTPUT control will not attenuate the output voltage to exactly zero, especially at the higher carrier frequencies.)

**4.13 Calibration Adjustment of Output Meter:** Having made the correct zero adjustment, turn the PL. VOLTS switch ON, and set the carrier frequency to approximately 1.0 Mc. Connect a vacuum-tube voltmeter, such as the GR Type 1800, across the NORMAL terminals of the termination unit. The internal impedance of the voltmeter used should be at least  $4000 \Omega$  at 1.0 Mc, and the calibration should be known to  $\pm 1\%$  or better. Adjust the OUTPUT control until the external voltmeter reads exactly 2.0 volts. Remove the snap button from the point marked CAL on the panel, and set the adjustment so that the OUTPUT meter reads exactly on the 2.0 point.

For this adjustment, the external VTVM leads should be as short as possible.

**4.14 Calibration Adjustment of Percentage Modulation Meter:** This setting has been carefully made at the factory, using precision measuring instruments, and should not be attempted unless suitable test equipment is available. The small snap-button located just above, and to the right of, the main tuning dial conceals the potentiometer used to set the sensitivity of the PERCENTAGE MODULATION meter. Individ-

ual potentiometers are provided for each range, and are automatically selected by the RANGE SELECTOR switch.

**4.15 Other Zero Adjustments:** The PERCENTAGE MODULATION meter should be set to zero by means of its manual adjustment when the instrument is fully warmed and in operation. Do this with the modulation switch in the OFF position and with the RANGE switch set on the D range. (On the A, B, and C ranges the carrier produces a small zero reading on the PERCENTAGE MODULATION meter.)

**4.16 Lubrication of Moving Parts:** The CARRIER FREQUENCY INCREMENT dial rotates on a steel shaft and bushing. Removal of this dial by loosening the two setscrews will expose an oil-hole in the end of the shaft. A few drops of machine oil per year will provide adequate lubrication.

All gears associated with the coil-changing mechanism, the dial drive, and the contact surfaces of the OUTPUT VOLTAGE control may be lubricated as necessary with Liqui-Moly N. V. Grease (obtainable from the Lockrey Company, College Point, N. Y.).

#### 4.2 INTERNAL ADJUSTMENTS

**4.21 Plate Voltage Adjustment:** This is located on the side of the power supply shelf. The plate voltage should be set to 290 volts by means of the potentiometer (R-28). An external meter, connected between terminal No. 1 of the choke (L-5) and ground, may be used as a reference voltmeter. A 1000-ohms-per-volt instrument is satisfactory. If the plate-voltage supply regulator is operating correctly, no change in the voltmeter reading will be observed as the supply line voltage is varied from 105 to 125 volts.

#### 4.3 LEAKAGE

The lower limit of usefulness of the attenuator is determined by the amount of radio-frequency leakage radiation from the generator. This should be less than 5 microvolts per meter at any point 24 inches from the panel. Care must be taken, in making adjustments, not to do anything that will cause the leakage to be excessive. The following are points to check.

**4.31** All the snap buttons should be in place and the holes should be clean so that the buttons are properly grounded.

# GENERAL RADIO COMPANY

Designation	Type	Location
P-1	Pilot Light	6.3-volt G.R. No. 2 LAP-939 Bayonet pin base.

The pilot light is replaceable from the front panel by unscrewing the front of the red jewel indicator, marked FIL. PL.; the fuses, by unscrewing the plugs marked FUSE, in the rear of the cabinet.

## SERVICE AND MAINTENANCE NOTES

### 1.0 FOREWORD

The two-year warranty given with every General Radio instrument attests the quality of materials and workmanship in our products. When difficulties do occur, our service engineers will assist in any way possible.

In case of difficulties that cannot be eliminated by the use of these service instructions, please write or phone our Service Department, giving full information of the trouble and of steps taken to remedy it. Be sure to mention the serial and type numbers of the instrument.

Before returning an instrument to General Radio for service, please write to our Service Department or nearest district office (see back cover), requesting a Returned Material Tag. Use of this tag will insure proper handling and identification. For instruments not covered by the warranty, a purchase order should be forwarded to avoid unnecessary delay.

### 2.0 GENERAL

If the generator becomes inoperative, a few simple checks should be made before removing the instrument from the cabinet.

- 2.1 Check power line source.
- 2.2 Test power supply cord for open circuit or poor contact in power outlet.
- 2.3 Check fuses mounted at back of cabinet for open circuits and be sure they are tight in their clips.

### 3.0 INPUT POWER

- 3.1 Input power, with the range switch on the blank position, is normally 110 watts  $\pm 5\%$  where the supply voltage is 115 volts. If the measured power is higher, test the 1N3196 rectifiers, the filter condensers, condensers C-23 and C-29 (through the righthand amplifier partition), and *test the by-pass condensers* for short circuit.

- 3.2 With the range switch set on the different coil ranges and the OSC. PLATE switch on, the normal power input is as follows:

RANGE	A	B	C	D	E	F	G
POWER (watts)	115	122	128	130	135	135	145

- 3.3 High power readings may indicate one or both Type 1614 Tubes (V-1 and V-2) defective. Examine the chokes L-2 and L-3, which will probably show evidence of overheating in case of a serious short in the oscillator or amplifier circuit.

If the wattage is low and the output voltmeter reads low on some ranges, test for short-circuited trimmer condensers on the oscillator or amplifier turrets. If the wattage is low and there is no output on any range, measure R-1, R-4 and R-56 (gray ceramic-coated resistors).

### 4.0 GENERATOR INOPERATIVE

- 4.1 See that all tube filaments are lighted. Test also the line filter for open circuit or ground; this is inside the cabinet, on the back.
- 4.2 If pilot lamp lights but neither meter operates, see Sections 4.0, 5.0, 6.0, 11.0 and 16.0.
- 4.3 If neither meter reads but the generator does have output, make sure that the Amperite Type 3-4 ballast tube V-10 has a faint glow or feels warm. Note that this tube is in series with the filaments of the 6AL5 tube V-9 and the 6AL5 voltmeter tube V-11.
- 4.4 If the carrier circuit only is inoperative, see Sections 5.0 through 11.0.
- 4.5 If the modulation circuit only is inoperative, see Sections 12.0 through 15.0.



## GENERAL RADIO COMPANY

### 5.0 NO READING OF OUTPUT VOLTAGE METER ON ANY RANGE

- 5.1 Check the action of all contacts on the coil turret mechanisms. These should operate properly in both directions of the coil turrets. The effect of poor contacts is more evident on F and G ranges.
- 5.2 Measure the output of the oscillator with a vacuum-tube voltmeter across lead from No. 5 terminal and C-5 and ground. The reading should be approximately 20 volts at 16 Mc, 11 volts at 32 Mc, and 9 volts at 50 Mc (G range).
- 5.21 If there is no reading, measure plate and screen voltages of V-1 (see table in Section 26). If there is no voltage in either instance, test for shorts and grounds in plate supply circuit. Also test VM5.
- 5.3 Measure the output of the amplifier with a vacuum-tube voltmeter across output lead connection and ground. The voltmeter should read at least 5 volts on all ranges.
- 5.31 If there is no reading, measure the plate and screen voltages of V-2.
- 5.4 Test V-9 (vacuum-tube voltmeter tube).
- 5.41 Check tube contacts in socket springs.
- 5.5 Check V-10 and V-11. The filaments of these tubes are in series with the filament of V-9. If an open circuit occurs in any one tube, the others are inoperative.
- 5.6 Test the lead through the meter case for a ground.
- 5.7 Defective meter. This should read full scale with 200 microamperes D.C.
- 5.71 If the meter is defective, a replacement should be ordered from the Service Department. The General Radio Company cannot assume responsibility for any local repairs to the meter, although such repairs might be necessary in an emergency.
- 5.8 Test C-14 (amplifier tuning condenser) for grounded rotor.
- 5.81 Test C-23 for breakdown or leakage.

- 5.9 Measure resistance values of R-17, R-21 and R-31 in output voltage meter circuit.
- 5.10 Measure condensers C-24, C-39, C-40 and C-43.
- 5.11 Measure output control (R8a and R8b).
- 5.111 Make certain contacts are properly in place.
- 5.112 Test windings for open circuits.
- 5.113 If contact surfaces of windings are dirty, clean with solution of half ether and half alcohol and wipe off residue with clean cloth. Lubricate surfaces with Liqui-Moly N. V. Grease to prevent undue wearing of contacts. See Section 25.0.
- 5.12 Check R-2 in oscillator and R-6 in amplifier for overheating or open circuits. Such conditions may indicate breakdowns in coils or condensers in either circuit.

### 6.0 NO READING OF OUTPUT VOLTAGE METER EXCEPT ON "G" RANGE

- 6.1 Measure resistance of R-1.

### 7.0 NO READING OF OUTPUT VOLTAGE METER ON ONE OR MORE RANGES

- 7.1 Test oscillator and amplifier coils in turrets for open or short circuits.
- 7.2 Check ground connection strap on oscillator turret (E range only). This may have become short circuited to the shaft of the trimmer condenser C-7e.
- 7.3 Test trimmer condensers on inoperative range for ground or short circuits.

### 8.0 LOW READING OF OUTPUT METER (USUALLY ON "G" RANGE)

- 8.1 Test tubes V-1 and V-2.
- 8.11 If replacement of either is necessary, select a tube with a transconductance of between 4600 and 5000. A tube with a value below 4600 may indicate low output on the meter. See Section 18.0.
- 8.2 Test capacitors C-5 and C-8 for open or short circuit and leakage. Any defect will cause a lowered output at the high end of the G range.
- 8.3 Measure resistors R-1 and R-4.



## GENERAL RADIO COMPANY

**8.4** Meter sensitivity may have changed. This is most noticeable on the G range.

**8.41** To check this, set frequency on D range at 1 Mc. Set attenuator at 1 volt position, measure voltage with a vacuum-tube voltmeter, and if reading is not 1 volt, adjust CAL. ADJ. control on panel.

**8.5** Measure plate supply voltage. This should be 290 v. Adjust as necessary using R-28.

**8.6** Test capacitor C-12 for leakage.

**8.7** Check R-54 to see if resistance has increased above 100 ohms. This is located under the socket at V-2, amplifier section, and is covered by tubing.

**8.8** Measure cathode resistors R-1 of V-1 and R-4 of V-2. See Section 3.3.

**8.9** Measure R-109, located in oscillator turret, Coil G.

**8.10** Make certain that the cam switch S-4 short circuits R-3 on the E, F and G ranges.

### 9.0 ERRATIC OUTPUT WITH OUTPUT VOLTAGE METER INDICATING NORMALLY

**9.1** Refer to Section 10.0 covering 805-P1 Termination Unit and Attenuator.

**9.11** Check soldered joint of connector strip between input wire and switch arm in multiplier section of attenuator. This should be resoldered if necessary.

**9.12** Be sure that the attenuator switch is making positive contact.

### 10.0 NO OUTPUT BUT OUTPUT VOLTAGE METER READS

**10.1** Type 805-P1 Termination Unit.

**10.11** This should be tested for open circuits in the cable and resistors R-201, R-202, and R-203.

**10.12** If one or more of the resistors are open, the voltage at the termination unit will be twice that indicated by the OUTPUT VOLTAGE meter if the termination switch is on NORMAL. A Type

805-337 Switch Plate and Contact Assembly containing these three resistors may be ordered from the Service Department. It is suggested that the defective assembly be returned for repairs and kept as a spare. After replacing a Type 805-337-2 Switch Plate, readjust the calibration of the OUTPUT VOLTAGE meter. See Section 22.0.

**10.13** *Caution:* Never coil the output cable tightly because the center conductor may break.

**10.2** If a check shows voltage at the input to the attenuator but no output at any setting, measure resistor R-123. This is located directly behind the panel jack and can be measured with the Leeds and Northrup bridge after the small circular plug has been pried out of the rear of the casting. *Caution: The current through R-123 must not exceed 50 milliamperes.*

**10.21** R-123 may be removed by unsoldering the rear connection and unscrewing the large hex nut on the panel jack. The large hex nut will expose a center "banana" plug, mounted upon an insulating disc, which is retained by a threaded ring. The latter has two slots, which will enable it to be turned counter-clockwise, for removal. Lift out the "banana" plug and mounting disc; R-123 will be found soldered to a terminal lug under the disc. Re-assemble the unit in the reverse order.

**10.3** Check the attenuator by connecting the Leeds and Northrup bridge across the panel jack. If all switch positions except the 1-volt do not give a 75-ohm reading, remove the large cover on the rear of the attenuator casting and measure the resistance cards. On the 1-volt position, the resistance should measure 475 ohms when the CARRIER FREQUENCY RANGE is on the blank position.

**10.4** With the output cable removed, the voltage at the panel jack, as measured with a Type 1800 Vacuum-Tube Voltmeter or equivalent, should be approximately twice that indicated by the OUTPUT VOLTAGE meter.

## 11.0 ERRATIC OPERATION OF OUTPUT VOLTAGE METER

11.1 Poor contacts in turret switches — this is most evident on F and G ranges.

*11.11* When the turret contact springs (mounted on condenser) are replaced make certain that the metal washer  $\frac{1}{2}$ " dia., .020" thick, clearance hole for No. 6 machine screw is placed under each spring to prevent it from sinking into the polystyrene base when the terminals are soldered.

11.2 Poor contacts in OUTPUT VOLTAGE control (R-8a and R-8b).

*11.21* Clean and lubricate. See Section 25.0.

11.3 Test V-1 and V-2.

11.4 Check vacuum-tube voltmeter circuit. See Sections 5.3 to 5.10 inclusive.

11.5 Poor contact of rotor brush contacts in both oscillator and amplifier tuning condensers, C-6 and C-14.

*11.51* To clean contact discs and brushes, remove bottom pan. Clean with solution of half ether and half alcohol, and wipe off residue with clean cloth. Apply a very thin layer of Liqui-Moly N. V. Grease.

*11.52* *Caution:* The condensers operate at almost 290 volts above ground. The small cup contacts at each end of the condenser rotors should *not* be lubricated.

11.6 Check insulating bushings of C-5 for cracks or looseness, especially if operation is erratic in G range only.

11.7 Check the fixed grounding contacts to make certain that they short circuit adjacent coil.

11.8 Check voltage regulator circuit. See Section 17.0.

11.9 If high zero reading of the OUTPUT VOLTAGE meter cannot be corrected by the adjustment ZERO ADJ., look for an open circuit in R-18 or R-20 potentiometer.

## 12.0 INOPERATIVE MODULATION METER

12.1 If PERCENTAGE MODULATION meter

does not operate on either 400 or 1000 cycles, check the setting of the corresponding panel adjustment beside the PERCENTAGE MODULATION control. These adjustments should be turned clockwise until the circuit just oscillates or until the meter can be set to 100% on the G range. A higher setting will increase the harmonic content of the audio output.

12.2 If PERCENTAGE MODULATION meter does not indicate when modulation is turned on, test for modulation on the carrier output by means of a radio receiver or a cathode-ray oscillograph.

12.3 If the output is properly modulated while the meter reads zero, see that the filament of V-10 (Type 3-4) is normal. Measure resistors R-32, -33, -47, and -60, and condensers C-28, -41, and -44. This may be more easily done by removal of side pan. If the meter itself is inoperative this should be returned to the Service Department for repairs. See Section 5.71. Try a new V-11 (6AL5) tube.

12.4 If no modulation is obtained in any position of S-1, set this switch to 400 cycles and check with phones between terminal No. 5 of V-4 (6L6GC) and ground. If the 400-cycle tone is heard, try a new 6L6GC tube and check condenser C-37.

12.5 If no tone appears at the V-4 grid, connect the phones between ground and pin 2 of V-3 (12AX7). If no tone is heard at this point, try a new 12AX7 tube (V-3). Measure the potentiometer R-38. Measure the voltages on V-3 and V-4. See tube data in Section 26.0.

## 13.0 MODULATION METER READS ON SOME SETTINGS

13.1 If normal modulation is obtained on both internal ranges but not when audio voltage is applied to the EXT. MODULATION terminals, see that an ohmmeter shows open circuit between these terminals. Check the contacts on switch located on oscillator turret gear.

13.2 If the external modulation and the 400-cycle internal modulation are normal but the 1000-cycle internal modulation does not operate, check contacts on switch S-1. Measure also resistors R-13 R-14 and R-16 and the potentiometer R-15. These are more easily accessible if the end pan is removed.

## GENERAL RADIO COMPANY

**13.3** If the external modulation and the 1000-cycle internal modulation are normal, but the 400-cycle internal modulation does not operate, check the contacts on PERCENTAGE MODULATION switch. Measure also resistors R-9, R-10, R-12, and R-35, and the potentiometer R-11. These are more easily accessible if the end pan is removed.

**13.4** If the external modulation is normal but neither 400-cycle nor 1000-cycle internal will operate, try a new V-3 (12AX7) tube. Test condensers C-18, -19, -20, -32, -33, and -59. These are more easily accessible if the end pan is removed.

**13.5** The meter and its circuit were designed to read correctly using modulation frequencies up to about 15 kc. The low end of the A range on the generator goes down to about 16 kc or slightly lower, and it is not practicable to design and manufacture a filter for the meter circuit which would pass all of the 15 kc and cut off all of the 16 kc, hence the response on the A-B ranges is limited to 1000 cycles.

### 14.0 LOW MODULATION METER READINGS

**14.1** In case of low output from the modulating system, try new tubes in the V-3 and V-4 sockets. Measure the tube voltages in accordance with the tube data given under Paragraph 18.0

**14.2** Measure resistors R-34, R-35, R-37, R-41 and R-42, and also condensers C-33, C-37 and C-47.

**14.3** Check the panel trimmers to see if they are set too fine. See Section 12.1.

### 15.0 ERRATIC OPERATION OF MODULATION METER

**15.1** See that the PERCENTAGE MODULATION potentiometer R-38 is clean and is making reliable contact. Check also the contacts on turret switch and try new tubes in the V-3 and V-4 positions (12AX7 and 6L6GC).

### 16.0 HUM MODULATION ON CARRIER

**16.1** This condition might be caused by the receiver under test having an excessive amount of hum in its power supply or pickup from external fields by the receiver itself. An unshielded lead, if used between the generator and the receiver, might also cause 60-cycle pickup. Although the

output impedance is very low, care should be taken to see that the high lead is kept short. This hum may also appear as a frequency modulation if the whole instrument is vibrated at 60 cycles or some other frequency, because of the transmission of the mechanical vibration to the main tuning condenser plates.

**16.2** In testing radio receivers, make certain to ground only the generator in order to avoid circulating currents in the ground lead. The receiver will automatically be grounded when connected to the generator through the shielded lead. Isolate line-connected AC-DC types of receivers with a small series condenser.

**16.3** If the receiver cannot be grounded because of design considerations, connect the generator to ground through a .02-microfarad condenser.

**16.4** If the output of the generator is too high, the receiver will be overloaded, causing the tubes to become microphonic and resulting in what might be mistaken for hum modulation of the generator carrier.

**16.5** Hum may also be caused by open circuit in condensers C-4, C-4A, C-25, C-26 or C-38. These should be checked.

**16.6** Select regulator tubes (V-6, V-7, V-12) that give satisfactory operation in the circuit. See Section 17.0.

### 17.0 VOLTAGE REGULATOR AND POWER SUPPLY

**17.1** The d-c voltage regulator on the plate voltage supply will maintain a value of 290 volts  $\pm 1\%$  over a range of line voltage variations from 105 to 125 volts.

**17.2** To measure the d-c voltage, connect any 1000-ohms-per-volt meter from ground to terminal No. 1 of the choke coil L-5 (upper right-hand shelf, viewed from rear). Adjust the potentiometer R-28 for a meter reading of 290 volts.

**17.3** Failure of R-28 to change the d-c voltage could be caused by an open circuit in R-27, R-28 or R-29. The voltage will remain high if R-27 is open, low if R-29 is open, and either high

## GENERAL RADIO COMPANY

or low depending upon the setting of the blade if R-28 is open.

- 17.4 If tube V-8 (0D3/VR150) does not light with the usual purple glow, test resistor R-25 for an open circuit. If this is not open, try a new V-8 tube.
- 17.5 If V-8 glows normally but the d-c voltage varies with changes in the line voltage, try a new Type 12AX7 Tube (V-7).
- 17.6 If the new V-7 tube affords no improvement, try new Type 6L6GC Tubes. No selection is necessary for any of these power-supply tubes as long as the new tubes are normal.
- 17.7 If no power at all is obtained from the plate supply, try replacing the 1N3196 rectifiers.

### 18.0 TUBE DATA AND TUBE REPLACEMENTS

- 18.1 Most of the tubes in the Type 805-D can be replaced without special selection or adjustment. These include the amplifier tube V-3, the modulation amplifier tube V-4, the power-rectifier tube, V-5, the plate voltage regulator tubes V-6, V-7 and V-8, the ballast tube V-10, the modulation voltmeter tube V-11, and the voltage regulator tube V-12.
- 18.2 Replacement of the oscillator tube V-1 makes no difference on the lower ranges but may cause some slight change in frequency at the high-frequency end of the 50-megacycle band. The 50-megacycle point should be checked to see if adjustment is necessary. Watch for motor-boat oscillations in some of these tubes at or near 50 megacycles.
- 18.3 In order to readjust the upper part of the G range, an adjustment must be made in the air-trimmer condenser C-7a. With the coil operating, take a long screw driver with a small tip and an insulated shaft and insert it through the hole in the panel which is uncovered by removing the upper one of the two snap buttons to the right of the main frequency dial. When the screw driver has been inserted in the screw-driver slot of the air trimmer condenser, it may be turned very slightly in one direction or the other in order to readjust this calibration. See Section 20.0.
- 18.4 If the modulation oscillator tube V-3 is replaced, it will be necessary only to check the

400-cycle and 1000-cycle modulation frequencies in accordance with Section 12.1.

- 18.5 When replacing tube V-9 for the OUTPUT VOLTAGE meter, measure the voltage at the termination of the output cable with a Type 1800 Vacuum-Tube Voltmeter. This tube must be selected both for calibration agreement with the 1800 and for electrical zero. When a tube has been selected which agrees in calibration with the voltage as measured on the Type 1800 Vacuum-Tube Voltmeter at the termination unit on the end of the output cable, it should be allowed to operate for several hours. The electrical ZERO ADJUSTMENT R-20 should then be set and the calibration again checked against the 1800. If the calibration then remains normal, there is not much likelihood that the tube characteristics will change after this first several hours of aging.

### 19.0 REMOVAL OF TURRETS

To clean thoroughly or to readjust the selector switch blades it may be desirable to remove the coil turrets.

- 19.1 Remove the instrument from the cabinet.
- 19.2 Remove the cover to the r-f compartment.
- 19.3 Remove the Type 1614 Tubes after marking them so they will not be interchanged.
- 19.4 Remove the heat shield between the oscillator tube and the oscillator coil turret.  
  
Note the setting of the RANGE SELECTOR switch and the positions of the turrets. They can then be taken out as soon as the three screws at each hub have been removed.
- 19.5 Replacement of the turrets is accomplished in the reverse order.

### 20.0 FREQUENCY CALIBRATION OF CARRIER

- 20.1 If an accurately known standard and means of comparing frequencies are available, the procedure is quite simple.
- 20.2 Remove the upper snap button located to the right of the main dial. The small screw head accessible through the exposed hole is the air trimmer adjustment for the range shown on the CARRIER FREQUENCY RANGE dial.
- 20.3 Remove the lower snap button located to the right of the main dial. Within this hole is the

## GENERAL RADIO COMPANY

head of the screw which turns the dust core in or out of the coil. *CAUTION:* High voltage appears between the condenser adjustment and the panel, necessitating the use of a screw driver with the shank insulated by a piece of tubing. The point should be ground fine and flat since a thick point may break the head of the coil screws.

- 20.4** Increasing the inductance will decrease the frequency at the low end of each range with little effect on the high end. Increasing the capacitance of the trimmer condensers will decrease the frequency of the high end of each range with little effect at the low end.
- 20.5** Similar adjustments for the amplifier are found under the snap buttons located beneath the cover of the CARRIER FREQUENCY RANGE dial. These are exposed by removing the three screws and the cover. These are tuned to give a maximum output on each range. The adjustment is not critical and trimmer condensers are not provided on the A, B, and C ranges.

### 21.0 CALIBRATION OF PERCENTAGE MODULATION METER

- 21.1** The PERCENTAGE MODULATION meter indications may be checked against a cathode-ray oscillograph or any precise means of measuring modulation such as the GR Type 1931 Modulation Monitor preceded by a linear amplifier.
- 21.2** With the 805-D controls set to 1 Mc the OSC. PLATE switch should be snapped OFF and the PERCENTAGE MODULATION meter should be set to zero by means of its mechanical zero adjustment. With the OSC. PLATE switch on and the MODULATION switch set to 1000, the 30%, 50% and 80% points should be measured. These points should all be correct to within  $\pm 10\%$  of the meter reading, and any errors should be corrected by changing resistor R-104 which is located under the snap button above and to the right of the main dial.
- 21.3** The other ranges should be similarly checked, but the zero setting of the meter must not be changed from the setting made at 1 Mc. (Note also that the accuracy on the G range is 15% of the meter reading.) Adjustments are made by changing the individual resistors which are

switched into position by the RANGE SELECTOR switch.

### 22.0 ADJUSTMENT OF OUTPUT VOLTAGE METER

- 22.1** Zero adjustment.
- 22.11** Set the mechanical adjustment to zero with the power turned off. Turn the power on and set the control marked ZERO ADJ. after the instrument has been warmed up and with the RANGE SELECTOR on the D range and the OSC. PLATE switch off.
- 22.2** Sensitivity (1 volt)
- 22.21** With the Type 805-P1 Termination Unit connected to the output jack, place the probe of a Type 1800 Vacuum-Tube Voltmeter directly against the terminals DIRECT and G of the termination unit with the switch set to NORMAL.
- With the Type 805-P2 Termination Unit connected to the generator, plug the probe of a Type 1800 Vacuum-Tube Voltmeter directly into the Type 874 output connector.
- 22.22** With the modulation switch turned off, the RANGE SELECTOR set to D, and the MULTIPLY BY switch set to 1 volt, the OUTPUT VOLTAGE control should be turned up until the Type 1800 Voltmeter indicates 1 volt.
- 22.23** Adjust the CAL. ADJ. until the OUTPUT VOLTAGE meter indicates 1 volt.
- 22.24** If the CAL. ADJ. control has insufficient range for this adjustment, try a new V-9 Tube. Changing the CAL. ADJ. potentiometer may require a resetting of the ZERO ADJ. (Section 22.11). Both settings should be re-balanced until they are correct.
- 23.0 MODULATION VTVM FREQUENCY CHARACTERISTIC**
- 23.1** With the RANGE SELECTOR set to the blank position between coils G and A and the modulation switch set at EXT., a Type

# GENERAL RADIO COMPANY

1304-B Oscillator should be connected to the EXTERNAL MOD. terminals.

**23.2** Turn the PERCENTAGE MODULATION control full clockwise, set the Type 1304-B at 1000 cycles, and set its output control to give a reading of 80% on the PERCENTAGE MODULATION meter.

**23.3** Change the frequency dial of the Type 1304-B from 1000 cycles down to 50 cycles, and from there to 15,000 cycles, noting the readings of the PERCENTAGE MODULATION meter. This should stay within 1 division of its setting at 1000 cycles.

**23.4** If the meter is not linear over this range, it would be advisable to try new V-11 (6H6), V-4 (6L6GC), or V-3 (12AX7) Tubes. The condenser C-68 should also be measured, and it may be advisable to change this to a different value, somewhere between 110 and 145  $\mu\mu\text{f}$ .

## 24.0 CONTINUITY CHECK

**24.1** The oscillator turret can be tested for continuity with an ohmmeter as follows. Terminal numbering shown in Figure 4.

### TERMINALS

Coil	1 and 3	2 and 4	3 and 2	5 and gnd. strap
A	750 K ohms $\pm 10\%$	200 ohms $\pm 10\%$	Open	25 K ohms $\pm 10\%$
B	0 ohms	60 ohms $\pm 10\%$	Open	50 K ohms $\pm 10\%$
C	0 ohms	10 ohms $\pm 20\%$	Open	20 K ohms $\pm 10\%$
D	0 ohms	2 ohms $\pm 10\%$	Open	25 K ohms $\pm 10\%$
E	0 ohms	0 ohms	Open	40 ohms $\pm 10\%$
F	2500 ohms $\pm 10\%$	0 ohms	Open	40 ohms $\pm 10\%$
G	5000 ohms $\pm 10\%$	0 ohms	Open	Terminals 5 and 6 0 ohms

**24.2** The amplifier turret may be checked for continuity with an ohmmeter as follows.

Terminal numbering shown in Figure 4.

### TERMINALS

Coil	1 and 3	2 and 4	2 and 3	6 and gnd. strap	6 and 4
A	20 ohms $\pm 10\%$	250 ohms $\pm 10\%$	Open	10 K ohms $\pm 10\%$	Open
B	10 ohms $\pm 10\%$	500 ohms $\pm 10\%$	Open	20 K ohms $\pm 10\%$	Open
C	0 ohms	7.5 ohms $\pm 10\%$	Open	Open	Open
D	0 ohms	2 ohms $\pm 10\%$	Open	Open	0 ohms
E	0 ohms	0 ohms	Open	Open	50 K ohms $\pm 10\%$
F	0 ohms	0 ohms	Open	Open	Open
G	0 ohms	0 ohms	Open	Open	Open

## 25.0 LUBRICATION

**25.1** The CARRIER FREQUENCY INCREMENT dial rotates on a steel shaft and bushing. Removal of this dial by loosening the two setscrews will expose an oil hole in the end of the shaft. A few drops of machine oil per year will provide adequate lubrication.

**25.2** All gears associated with the coil changing mechanism, the dial drive and the contact surfaces of the OUTPUT VOLTAGE control, and all potentiometers and rheostats should be lubricated with Liqui-Moly N. V. Grease (obtainable from the Lockrey Company, College Point, N. Y.).

# GENERAL RADIO COMPANY

## 26.0 VACUUM TUBE DATA

TUBE (TYPE)	PIN NO.	*FREQ RANGE	VOLTS TO GND	TUBE (TYPE)	PIN NO.	*FREQ RANGE	VOLTS TO GND	TUBE (TYPE)	PIN NO.	*FREQ RANGE	VOLTS TO GND	TUBE (TYPE)	PIN NO.	VOLTS TO GND
V1 (6L6) R-F OSC	1		0	V1 (cont.)		E	9.2	V2 (cont.)		B	12.2	V7 (12AX7) REG	1,6	280
	2		6.3AC			F	7.05			C	19.8		2,7	148
	3	A	293			G	0			D	35.5		3	150
		B	291	V2 (6L6) R-F AMP	1		0		E	32.5	4,5		150 ±6.3	
		C	290		2		6.3AC		F	22.5	8,9		150	
		D	292		3	A	268	V3 (12AX7) AUDIO OSC	1		208	V8 (0D3) REG	2	0
		E	290			B	251		2		0		5	152
		F	288			C	248		3		2.0	V9 (6AL5) CARRIER VTVM	1	0
		G	282			D	218		4,5		6.3AC		3	0
		A	57			E	222		6		180		4	6.5AC
		B	46			F	243		7		0	V10 (AMP 3-4) REG	2	15.2AC
		C	69.5			G	240		8		1.5		7	6.5AC
		D	14.2			A	42		9		0	V11 (6H6) MOD VTVM	1	0
		E	19.5			B	71.5		V4 (6L6) MOD	1			0	2
		F	40			C	155	2			6.5AC		3	-0.32
		G	67		D	220	3			280	4		0	
		A	-9.2		E	183	4			215	5		-0.32	
		B	0		F	183	5			0	7	22.5AC		
		C	0		G	180	7		0	V12 (6L6GC) REG	2	290 ±3.2		
		D	0		A	-0.38	8		11.5		3,4	480		
		E	0		B	-4.8	V6 (6L6GC) REG	2			290 ±3.2	5	280	
		F	-4.5		C	0		3,4			480	7	290 ±3.2	
		G	-16.5		D	0		5			280	8	290	
		A	0		E	0		7		290 ±3.2				
	B	3.0		F	0	8			290					
	C	4.35		G	0									
	D	4.1		A	5.85									

### NOTES

All voltages measured from pin to ground (except where otherwise indicated) with 20,000 ohm/volt meter. Frequency set at 1 Mc except where frequency range position is specified. D-c voltages may vary by ±20%.

\*Where frequency range is indicated, the middle of the range is used:

A - 30 kc      C - 300 kc      E - 3 Mc      G - 30 Mc  
 B - 100 kc    D - 1 Mc        F - 10 Mc

## 27.0 TRANSFORMER VOLTAGE DATA

### TERMINALS

7 to gnd  
 12 to gnd  
 6 to 5  
 8 to 9  
 10 to 11  
 15 to 14

### VOLTAGE

455 v rms ac  
 455 v rms ac  
 22.5 v  
 6.4 v  
 6.4 v  
 6.4 v



GENERAL RADIO COMPANY

REMOVE FOR  
ACCESS TO THE  
OUTPUT ATTENUATOR

REMOVE FOR ACCESS TO THE  
RF OSCILLATOR AND  
RF AMPLIFIER

REMOVE FOR ACCESS TO  
AF OSCILLATOR AND  
POWER SUPPLY

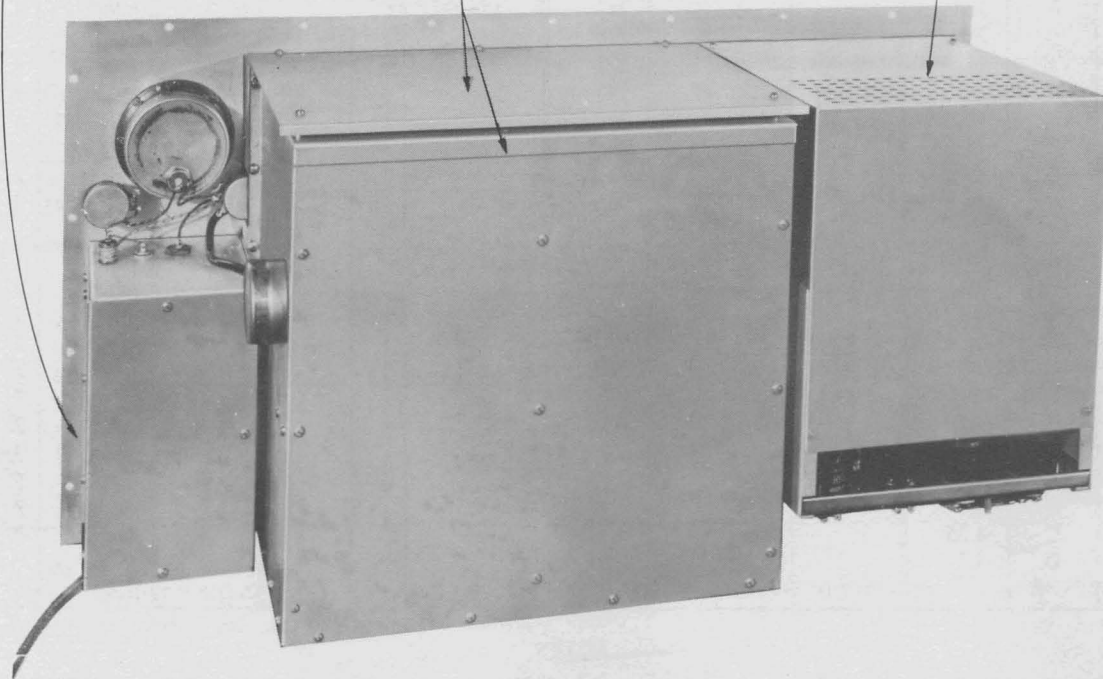

FIGURE 12. REAR VIEW WITH CABINET REMOVED SHOWING POSITION OF SHIELDS.



PARTS LIST (Cont.)

				PART NO. (NOTE A)				PART NO. (NOTE A)
CAPACITORS (NOTE C)	C20	0.002µf ± 1%	600dcwv	COM-45C	C117	0.01µf ±10%	500dcwv	COM-41B
	C21	0.001µf ±10%		COU-9	C118	0.015µf ±10%	600dcwv	COM-50B
	C22	0.001µf ±10%		COU-9	C119	250 ±10%	300dcwv	COM-20B
	C23	500 ±10%		COU-8-2	C201	200 ± 5%	300dcwv	COM-20B
	C24	750 ±20%		(NOTE D)	C202	400 ± 5%	300dcwv	COM-20B
	C25	0.5µf ±10%	1000dcwv	COL-24	F1	FUSE, 1.6 amp Slo-Blo Type 3AG (for 115v)		FUF-1
	C26	10µf ±10%		COL-9(2)	F1	FUSE, 0.8 amp Slo-Blo Type 3AG (for 230v)		FUF-1
	C27	0.25µf ±10%		COL-3	F2	FUSE, 1.6 amp Slo-Blo Type 3AG (for 115v)		FUF-1
	C28	0.47µf ±10%	1000dcwv	COW-25	F2	FUSE, 0.8 amp Slo-Blo Type 3AG (for 230v)		FUF-1
	C29	500 ±10%		COU-8-2	L1	INDUCTOR		P-432-315
	C30	50 ±10%		COU-24	L2	CHOKE, 2.5 mh		CHA-597
	C31	50 ±10%		COU-8-2	L3	CHOKE, 2.5 mh		CHA-597
	C32	0.047µf ±10%	600dcwv	COW-25	L4	CHOKE, 2.5 mh		CHA-597
	C34	0.05µf ±10%	600dcwv	COM-50B	L5	INDUCTOR		485-427-2
	C35	0.047µf ±10%	600dcwv	COW-25	L6	INDUCTOR		804-310
	C36	0.22µf ±10%	1000dcwv	COW-25	L7	INDUCTOR		804-310
	C37	20µf +50% -10%		Part of COEB-25	L8	INDUCTOR		485-428-2
	C38	40µf +50% -10%		Part of COEB-25	L9	CHOKE, 2.5 mh		CHA-597
	C39	100 ±10%		COU-8-2	L10	INDUCTOR		805-406
	C40	0.001µf ±10%	500dcwv	COM-21B	L11	INDUCTOR		805-406
	C41	0.001µf ±10%	500dcwv	COM-21B	L12	INDUCTOR		805-873
	C42	500 ±10%		COU-8-2	L101	CHOKE, 2.5 mh		CHA-597
	C43	0.001µf ±10%		COU-9	L102	INDUCTOR		805-39-2
	C44	0.001µf ±10%		COU-9	L201	INDUCTOR, 20 µh		Part of 805-319
	C45	0.001µf ±20%		(NOTE D)	L202	INDUCTOR		805-870
	C46	0.001µf ±10%		COU-9	M1	METER, 200 µa		MEDS-112
	C47	20µf + 5% -10%		Part of COEB-25	M2	METER, 200 µa		MEDS-113
	C48	0.001µf ±10%	500dcwv	COM-21B	P1	LAMP, 6.3v Mazda #44		2LAP-939
	C49	0.001µf ±10%	500dcwv	COM-21B	S1	SWITCH		SWRW-28
	C50	0.001µf ±10%	500dcwv	COM-21B	S2	SWITCH, dpst		SWT-333
	C51	0.001µf ±10%	500dcwv	COM-21B	S3	SWITCH, spdt		SWT-320
	C53	240 ±10%		COU-10	S4	SWITCH		805-426
	C54	400 ±10%	300dcwv	COM-20B	T1	TRANSFORMER		565-405-2
	C55	0.02µf ±10%	600dcwv	COM-50B	V1	TUBE		1614
	C56	0.02µf ±10%	600dcwv	COM-50B	V2	TUBE		1614
	C57	0.05µf ±10%	600dcwv	COM-50B	V3	TUBE		12AX7
	C58	100 ±10%	300dcwv	COM-20B	V4	TUBE		6L6GC
	C59	20 ±20%	300dcwv	COC-60	V6	TUBE		6L6GC
	C61	100 ±10%		COU-8-2	V7	TUBE		12AX7
	C64	40µf		COE-11	V8	TUBE		OD3/VR150
	C65	300 ±10%	300dcwv	COM-20B	V9	TUBE		6AL5
	C66	0.01µf ±10%	500dcwv	COM-41B	V10	TUBE		Amp 3-4
	C67	0.001µf ±10%	500dcwv	COM-30B	V11	TUBE		6AL5
	C68	100 ±20%	300dcwv	COC-60	V12	TUBE		6L6GC
	C69	0.001µf ±20%		(NOTE D)	CR-1	RECTIFIER		1N3196
	C70	0.01µf ±20%		COC-62	CR-2	RECTIFIER		1N3196
	C101	0.005µf ±10%	500dcwv	COM-41B	CR-3	RECTIFIER		1N3196
C103	50 ±10%	300dcwv	COM-20B	CR-4	RECTIFIER		1N3196	
C104	200 ±10%	300dcwv	COM-20B	Oscillator Coils		Amplifier Coils		
C105	5 ±10%	300dcwv	COM-20B	805-341	A	805-491		
C109	35 ±10%	300dcwv	COM-20B	805-392-2	B	805-492-2		
C112	60 ±10%	300dcwv	COM-20B	805-393-2	C	805-493-2		
C113	500 ±10%	300dcwv	COM-20B	805-394	D	805-494-2		
C114	800 ±10%	300dcwv	COM-20B	805-395	E	805-495-2		
C115	500 ±10%	300dcwv	COM-20B	805-398	F	805-498		
C116	300 ±10%	300dcwv	COM-20B	805-449	G	805-499		

NOTES:

(A) GR Type designations for resistors and capacitors are:

- COA - Capacitor, air
- COE - Capacitor, electrolytic
- COEB - Capacitor, electrolytic block
- COL - Capacitor, oil
- COM - Capacitor, mica
- COU - Capacitor, unclassified
- POSC - Potentiometer
- POSW - Potentiometer
- REC - Resistor, composition
- REF - Resistor, film

- REPO - Resistor, power
- REPR - Resistor, precision
- REW - Resistor, wire-wound

(B) All resistances are in ohms except as otherwise indicated by k (kilohms) or M (megohms).

(C) All capacitances are in micromicrofarads except as otherwise indicated by µf (microfarads).

(D) Part of V9 tube socket.

When ordering replacement components, be sure to include complete description as well as Part Number. (Example: R85, 51k ±10%, 1/2w, REC-20BF.)



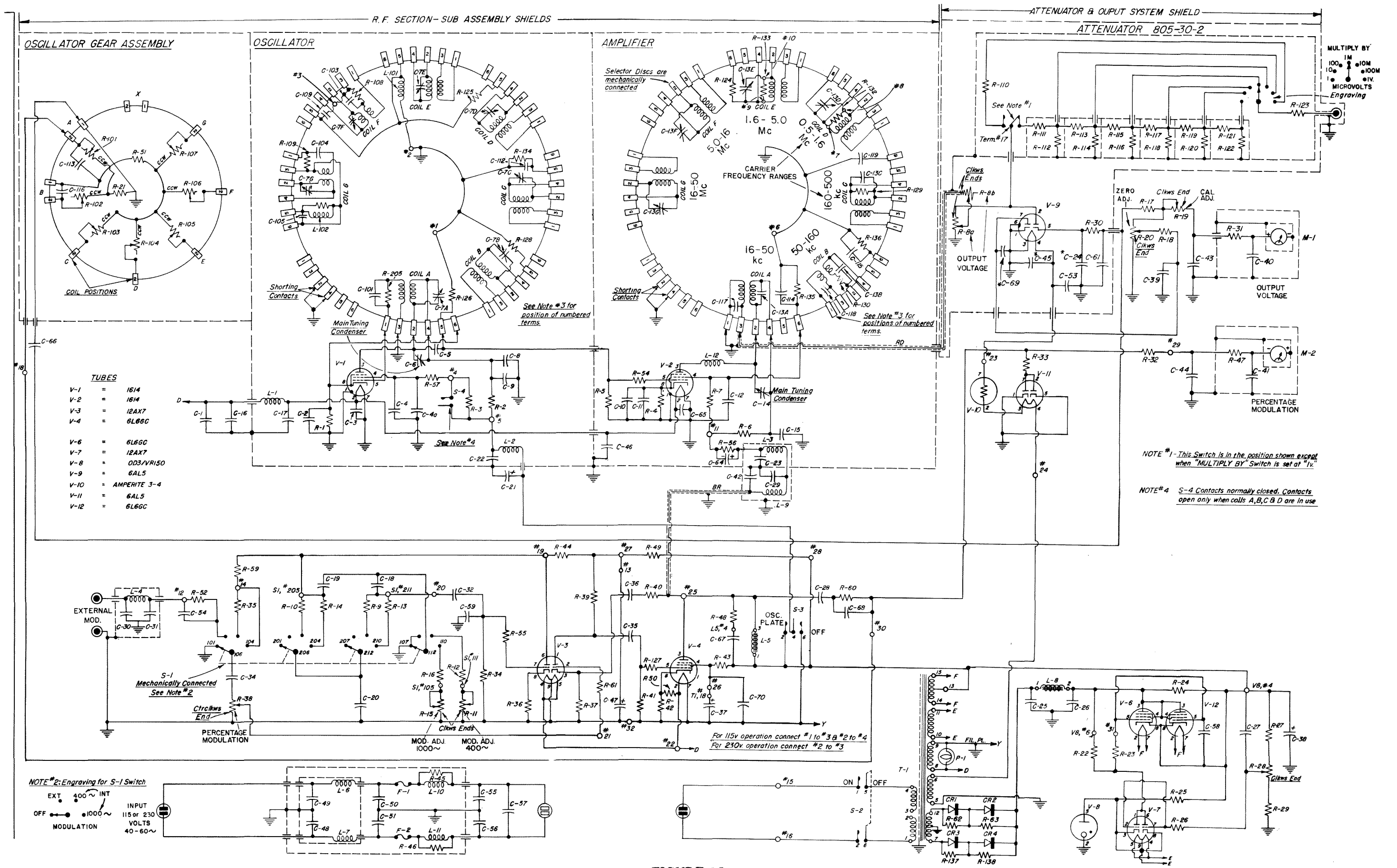
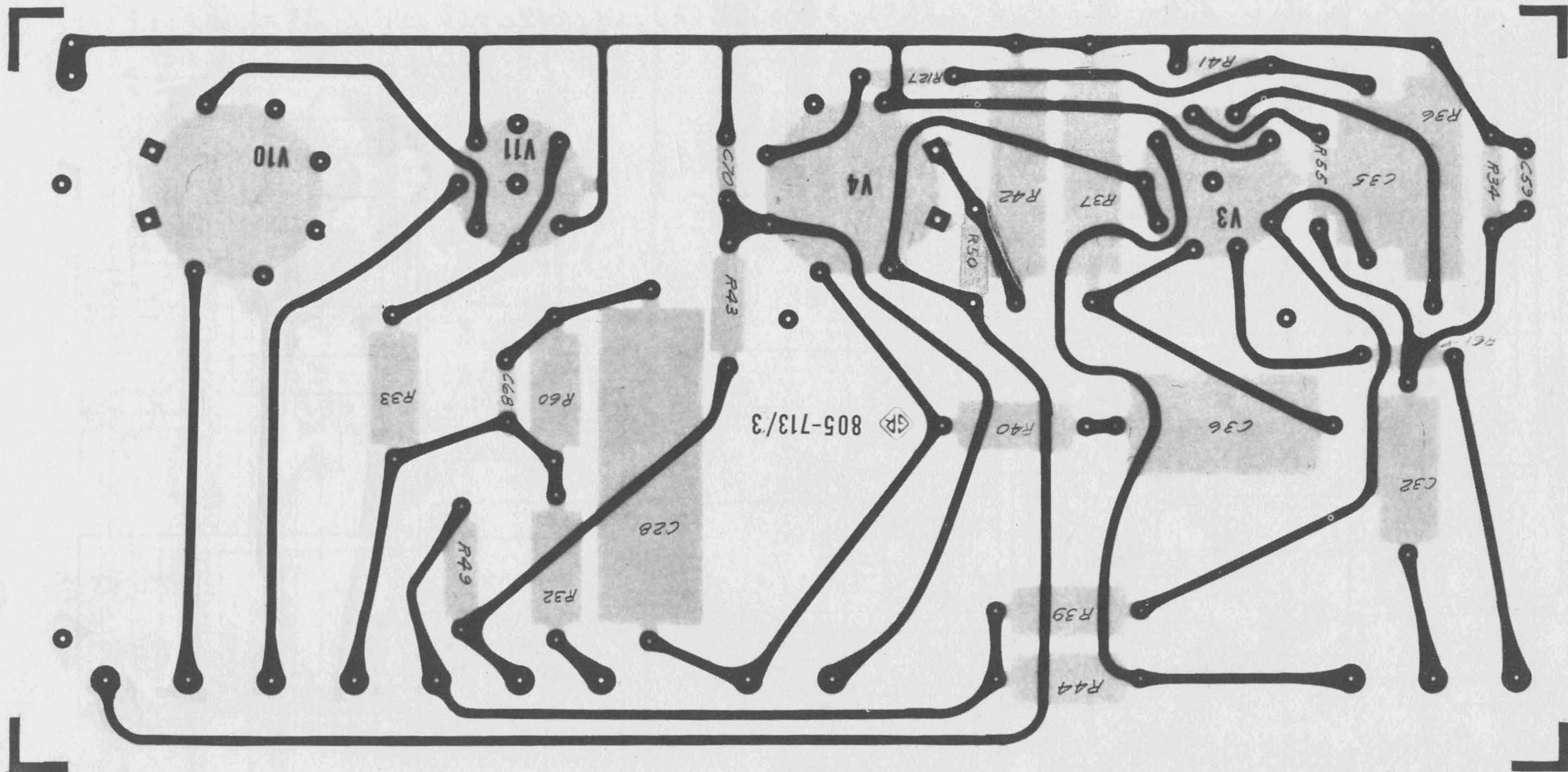

FIGURE 15

WIRING DIAGRAM FOR TYPE 805-D STANDARD-SIGNAL GENERATOR.

Etched Board Layout on Next Page





COMPONENT LAYOUT ON ETCHED BOARD



21

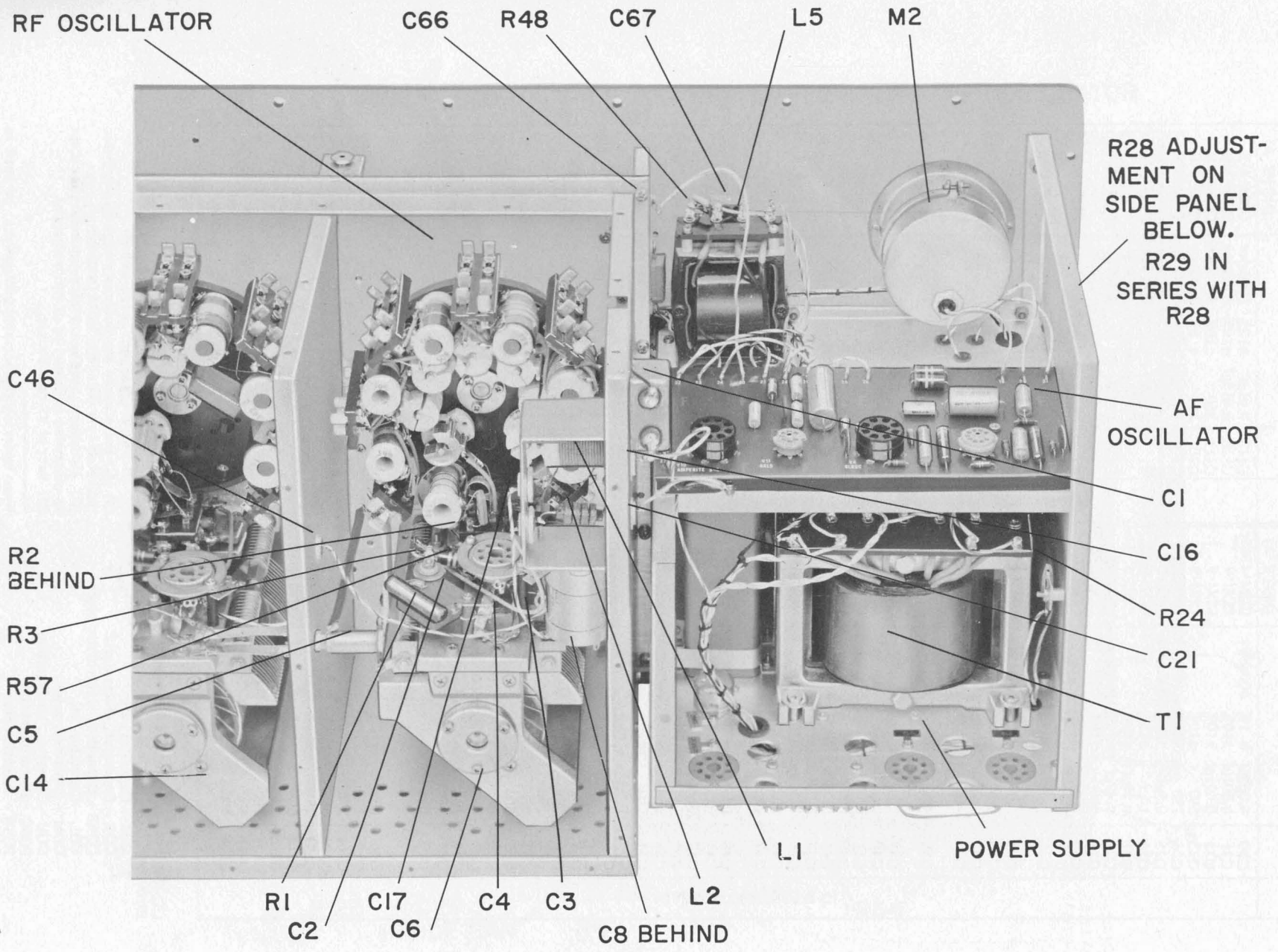

GENERAL RADIO COMPANY

FIGURE 13. VIEW OF POWER SUPPLY AND CARRIER OSCILLATOR WITH PARTS IDENTIFICATION.

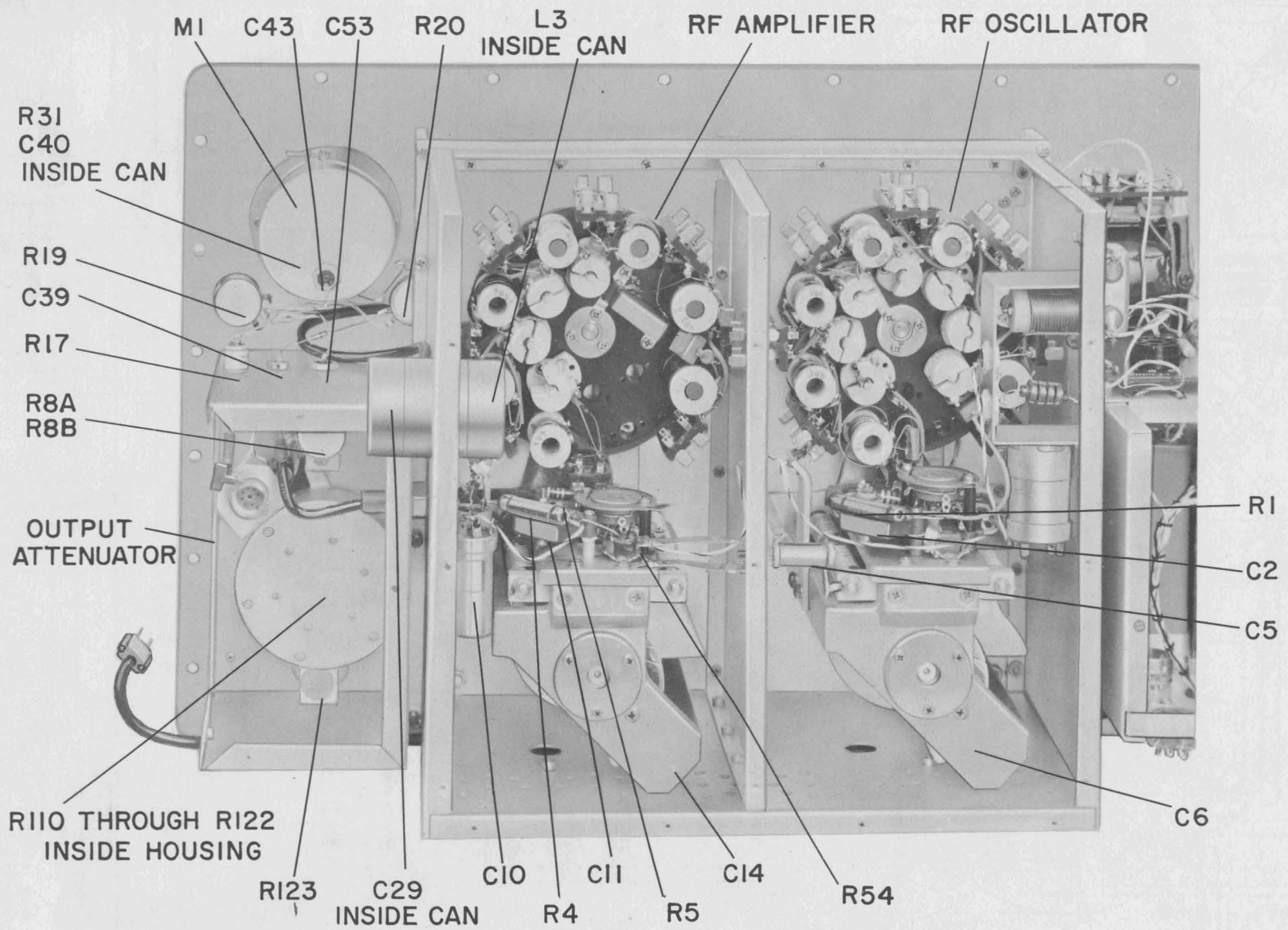

24

GENERAL RADIO COMPANY

FIGURE 14. VIEW OF R-F AMPLIFIER AND OUTPUT SYSTEM WITH PARTS IDENTIFICATION



# GENERAL RADIO COMPANY

WEST CONCORD, MASSACHUSETTS

EMerson 9-4400

Mission 6-7400

## DISTRICT OFFICES

### NEW YORK

Broad Ave. at Linden, Ridgefield, N. J.  
Telephone N.Y. WOrth 4-2722  
N.J. WHitney 3-3140

### SYRACUSE

Pickard Bldg., E. Molloy Rd., Syracuse 11, N. Y.  
Telephone GLenview 4-9323

### PHILADELPHIA

1150 York Rd., Abington, Penna.  
Telephone TUrner 7-8486  
Phila., HAncock 4-7419

### WASHINGTON

8055 13th St., Silver Spring, Md.  
Telephone JUniper 5-1088

### FLORIDA

113 East Colonial Drive, Orlando, Fla.  
Telephone GArden 5-4671

### CHICAGO

6605 West North Ave., Oak Park, Ill.  
Telephone Vllage 8-9400

### LOS ANGELES

1000 N. Seward St., Los Angeles 38, Calif.  
Telephone HOLlywood 9-6201

### SAN FRANCISCO

1186 Los Altos Ave., Los Altos, Calif.  
Telephone WHitecliff 8-8233

### CANADA

99 Floral Pkwy., Toronto 15, Ont.  
Telephone CHerry 6-2171

## REPAIR SERVICES

### EAST COAST

General Radio Company  
Service Department  
22 Baker Ave., W. Concord, Mass.  
Telephone EMerson 9-4400

### NEW YORK

General Radio Company  
Service Department  
Broad Ave. at Linden, Ridgefield, N. J.  
Telephone N.Y. WOrth 4-2722  
N.J. WHitney 3-3140

### MIDWEST

General Radio Company  
Service Department  
6605 West North Ave., Oak Park, Ill.  
Telephone Vllage 8-9400

### WEST COAST

General Radio Company  
Service Department  
1000 N. Seward St.  
Los Angeles 38, Calif.  
Telephone HOLlywood 9-6201

### CANADA

General Radio Company  
Service Department  
99 Floral Pkwy., Toronto 15, Ont.  
Telephone CHerry 6-2171

(Representatives in Principal Overseas Countries)

Printed in USA

