

OPERATING INSTRUCTIONS



TYPE 1230-A

**DC AMPLIFIER AND
ELECTROMETER**

1230-A

GENERAL RADIO COMPANY

Blank Page

OPERATING INSTRUCTIONS

TYPE 1230-A

**DC AMPLIFIER AND
ELECTROMETER**

Form 1230-0100-F
February, 1962

**G E N E R A L R A D I O C O M P A N Y
WEST CONCORD, MASSACHUSETTS, USA**

SPECIFICATIONS

VOLTAGE RANGES	± 30 , 100 and 300 dc millivolts full-scale; ± 1 , 3 and 10 dc volts full-scale. Accuracy is $\pm 2\%$ of full scale on all but the 30 mv range where it is $\pm 4\%$ of full scale.
CURRENT RANGES	± 1 milliampere (10^{-3} amp) dc full scale to ± 300 millimicroamperes (3×10^{-13} amp) dc full scale, in 20 ranges (two per decade).
ACCURACY	$\pm 3\%$ of full scale from 10^{-3} amp to 10^{-9} amp, and $\pm 10\%$ of full scale from 3×10^{-10} amp to 3×10^{-13} amp.
RESISTANCE RANGES	Direct reading in resistance from 300 kilohms to 10 megamegohms (10^{13} ohms) at full scale (5×10^{14} ohms at smallest meter division). There are 16 ranges (two per decade). At full scale deflection, accuracy is $\pm 3\%$ from 3×10^5 ohms to 10^{10} ohms, and $\pm 8\%$ from 3×10^{10} ohms to 10^{13} ohms. At one third of full scale deflection, the error can possibly be an additional 4%. The voltage across the unknown resistance is 9 volts. The resistance range may be extended considerably by the use of external batteries and the most sensitive voltage range. With a 300-volt battery, the highest resistance range is 10^{15} ohms full scale (6×10^{16} ohms at the smallest meter division). The full battery voltage appears across the unknown resistance.
RESISTANCE STANDARDS	10^4 , 10^5 , 10^6 , 10^7 , 10^8 , 10^9 , 10^{10} , and 10^{11} ohms. The switch also includes zero and infinity positions. The 10^4 - and 10^5 -ohm resistors are wire wound and are accurate to 0.25%. The 10^6 -, 10^7 -, and 10^8 -ohm resistors are of deposited-carbon construction and are accurate to 1%. The 10^9 , 10^{10} , and 10^{11} resistors are carbon, and have been treated to prevent adverse humidity effects, and are accurate to 5%. A switch position permits a quick check of the higher resistance standards in terms of the wire-wound units.
INPUT RESISTANCE	The input resistance is determined by the setting of the resistance standards switch. In the infinity position, it is about 10^{14} ohms.
INPUT CAPACITANCE	Less than 35 μmf .
DRIFT	Less than 2 mv per hour after 1 hour warmup.
OUTPUT	Voltage, current, and resistance are indicated on a panel meter. Terminals are available for connection of a recorder (such as the General Radio Type 1521-A Graphic Level Recorder or the Esterline-Angus 5-ma or 1-ma graphic recorder). The recorder resistance can be up to 1500 ohms.
FREQUENCY CHARACTERISTIC	With a 1500-ohm load at the OUTPUT terminals, the frequency characteristic is flat within 5% from zero to 10, 30, 100, 300, 1000, and 3000 cps. at the 30-, 100-, 300-millivolt, 1-, 3-, and 10-volt ranges, respectively.
TERMINALS	The input is connected through a Type 874 coaxial terminal assembly. In addition, there are "low" terminals to provide versatility in guard and ground connections, as required, for example, in "three-terminal network" measurements.
INPUT SWITCH	A panel switch permits disconnecting the unknown without upsetting either the unknown or the measuring circuit.
INPUT INSULATION	Entirely teflon or siliconed glass.
TEMPERATURE, HUMIDITY, LINE-VOLTAGE EFFECTS	Negligible.
TUBES	One 5886 electrometer tube, one CK6418, one 6AN5, one 6AL5, one 6627, and three OB2 tubes.
ACCESSORIES SUPPLIED	One Type 874-411 Adaptor, one Type 1230-P1-300 Panel Adaptor Assembly, two Type 274-MB Plugs, one Type 274-SB Plug, spare fuses, and power cord.
ACCESSORIES AVAILABLE	Type 1230-P1 Component Shield, Esterline-Angus case.
MOUNTING	Aluminum front and rear panels finished in gray lacquer and encased in an aluminum gray sleeve-like cabinet. The instrument can be mounted (by four screws in the rear panel) inside an Esterline-Angus case.
POWER SUPPLY	105 to 125 (or 210 to 250) volts, 50 to 60 cps. Power input is approximately 45 watts at 115 volts.
DIMENSIONS	Width 7-5/8 in., Height 13-1/4 in., Depth 9 in., (340 by 195 by 230 mm) over-all.
WEIGHT	15-1/4 lb (7 kg).

TABLE OF CONTENTS

	Page
Section 1 INTRODUCTION	1
1.1 General	1
1.2 Purpose	1
1.3 Controls	1
1.4 Connections	1
Section 2 THEORY OF OPERATION	2
2.1 Voltage Measurements	2
2.2 Current Measurements	2
2.3 Resistance Measurements	2
2.4 Output Circuit	2
2.5 Ground and Guard	3
2.6 Resistance Standards Check	3
2.7 Stability	3
Section 3 INSTALLATION	3
3.1 Power Supply	3
3.2 Recorder	3
3.3 Shielding of Unknown	3
Section 4 OPERATING PROCEDURE	4
4.1 Preliminary Settings	4
4.2 Voltage Measurements	5
4.3 Current Measurements	5
4.4 Resistance Measurements with Internal D-C Supply	6
4.5 Resistance Measurements with External D-C Supply	7
4.6 Measurement of Capacitor Leakage Resistance	8
4.7 Type 1230-P1 Component Shield	9
4.8 High-Voltage Measurements	9
Section 5 CHECKS AND ADJUSTMENTS	10
5.1 Checking Internal Resistance Standards	10
5.2 Auxiliary Zero Control	10
5.3 Internal Voltage Adjustment	10
Section 6 SERVICE AND MAINTENANCE	11
6.1 General	11
6.2 Removal of Cabinet	11
6.3 Tube Replacement and Adjustment	11
6.4 Opening the Instrument	11
6.5 Voltage and Resistance Chart	11
Section 7 PARTS LIST	14



Figure 1. Front and Rear Views of Type 1230-A D-C Amplifier and Electrometer.

Section 1

INTRODUCTION

1.1 GENERAL. The Type 1230-A D-C Amplifier and Electrometer (Figure 1) is a power-line-operated, direct-current, vacuum-tube voltmeter of high sensitivity. The instrument, which uses neither a chopper nor a vibrator, has three direct-coupled stages of amplification. Its input resistance is extremely high because an electrometer-type tube is used in the first stage. The output is indicated on a 5-ma panel meter or on a recorder.

1.2 PURPOSE. The instrument is essentially a millivoltmeter. A panel switch, which allows the selection of a resistance standard in decimal steps from 10^4 to 10^{11} ohms, adapts the instrument for use as a millimicroammeter and a megamegohmmeter. The provision for recording extends the use of the equipment to monitoring and curve-tracing applications.

1.3 CONTROLS. The following table lists the controls on the panel of the instrument:

<u>Name</u>	<u>Description</u>	<u>Use</u>
MV-VOLTS-OHMS	Nine-position rotary switch	Selects voltage and resistance ranges.
INPUT RESISTANCE OR OHMS MULTIPLIER	10-position rotary switch	Selects resistance standard.
POLARITY	Toggle switch	Selects polarity of input voltage or current.
ZERO (PUSH)	Push-lock button	Permits disconnecting input for checking meter zero.
POWER	Four-position rotary switch	Controls power-line connection. Meter open for first two positions.
GROUND	Three-position switch	Grounds one of three rear-panel terminals.
COARSE-ZERO-FINE	Two rotary knobs	Set meter to zero.

1.4 CONNECTIONS. The following table lists the rear-panel connections on the instrument:

<u>Name</u>	<u>Description</u>	<u>Use</u>
INPUT	Coaxial connector	Input connection
none	Jack-top binding post	Ground terminal
I, R, E	Jack-top binding posts (3)	Low-impedance-level guard terminals
OUTPUT +, -	Jack-top binding posts (2)	Terminals for connecting recorder or accessory meter
115 (or 230) VOLTS 50 - 60 ~	Recessed male connector	Power input

Section 2

THEORY OF OPERATION

2.1 VOLTAGE MEASUREMENTS.

2.1.1 The amplifier circuit is essentially a cathode-follower, where the "tube" is a three-stage, direct-coupled amplifier. (See Figure 2.) The net transconductance is so great that the voltage change across the cathode resistor is essentially the same as the voltage applied to the input terminals. The panel meter reads the current change in the cathode resistor (R_B) and is calibrated to read voltage directly. Different ranges are obtained by the selection of different values for R_B . The meter zero is the same for all ranges. The full-scale ranges are 30, 100, and 300 millivolts, 1, 3, and 10 volts. The corresponding R_B values are 6, 20, 60, 200, 600, and 2000 ohms.

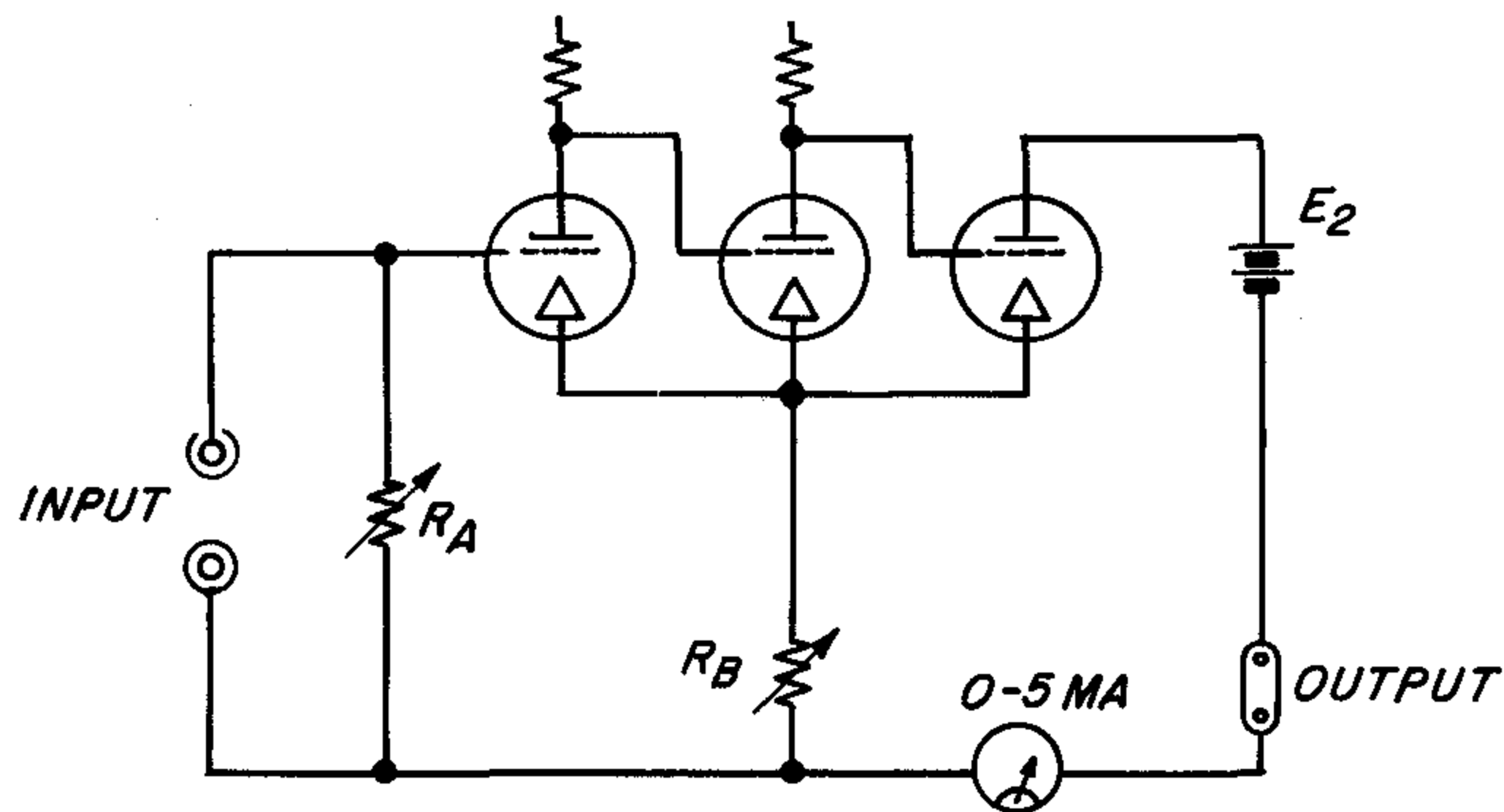

Figure 2. Cathode-Follower Circuit.

2.1.2 Because the first stage is an electrometer tube, the grid current is small (about 10^{-14} amperes). The glass envelope of the tube has been treated with General Electric Dri-Film SC-87, and all other insulation of the input circuit is of teflon. As a consequence, the input resistance is determined by the setting of the INPUT RESISTANCE switch (R_A , Figure 2), even under conditions of high humidity.

2.2 CURRENT MEASUREMENTS.

2.2.1 One method of measuring current is to note the voltage developed across the selected resistance standard (R_A) by the unknown current. Since the resistance values of the standards are multiples of 10, the meter reads current directly. The "ammeter resistance" of the instrument is equal to the

resistance R_A , as determined by the setting of the INPUT RESISTANCE switch.

2.2.2 A second method of measuring current results in an appreciably lower "ammeter resistance". Since the voltage at the input and the voltage across R_B are practically equal and of the same polarity, the voltage difference from the high INPUT terminal (grid of first tube) to the high side of R_B (I, Figure 3) is very small (about $150 \mu\text{v}$ at full scale). Any current source connected between these two points cannot develop appreciable voltage between the points, and the "ammeter resistance" is therefore very low. The unknown current, however, still flows through R_A , and therefore the instrument indicates current in the same manner as that described in paragraph 2.2.1. The lower "ammeter resistance" is obtained at some sacrifice in stability, however, if the source impedance is relatively low. (Refer to paragraph 4.3.)

2.3 RESISTANCE MEASUREMENTS. Resistance measurements are made by means of an auxiliary voltage, E_3 (9.1 volts if internal, any voltage up to at least 600 volts if external), connected in the series network of standard and unknown resistors (see Figure 3). The resultant voltage drop across the standard resistor is a measure of the unknown resistance. The meter is calibrated to indicate this resistance directly when E_3 is internal.

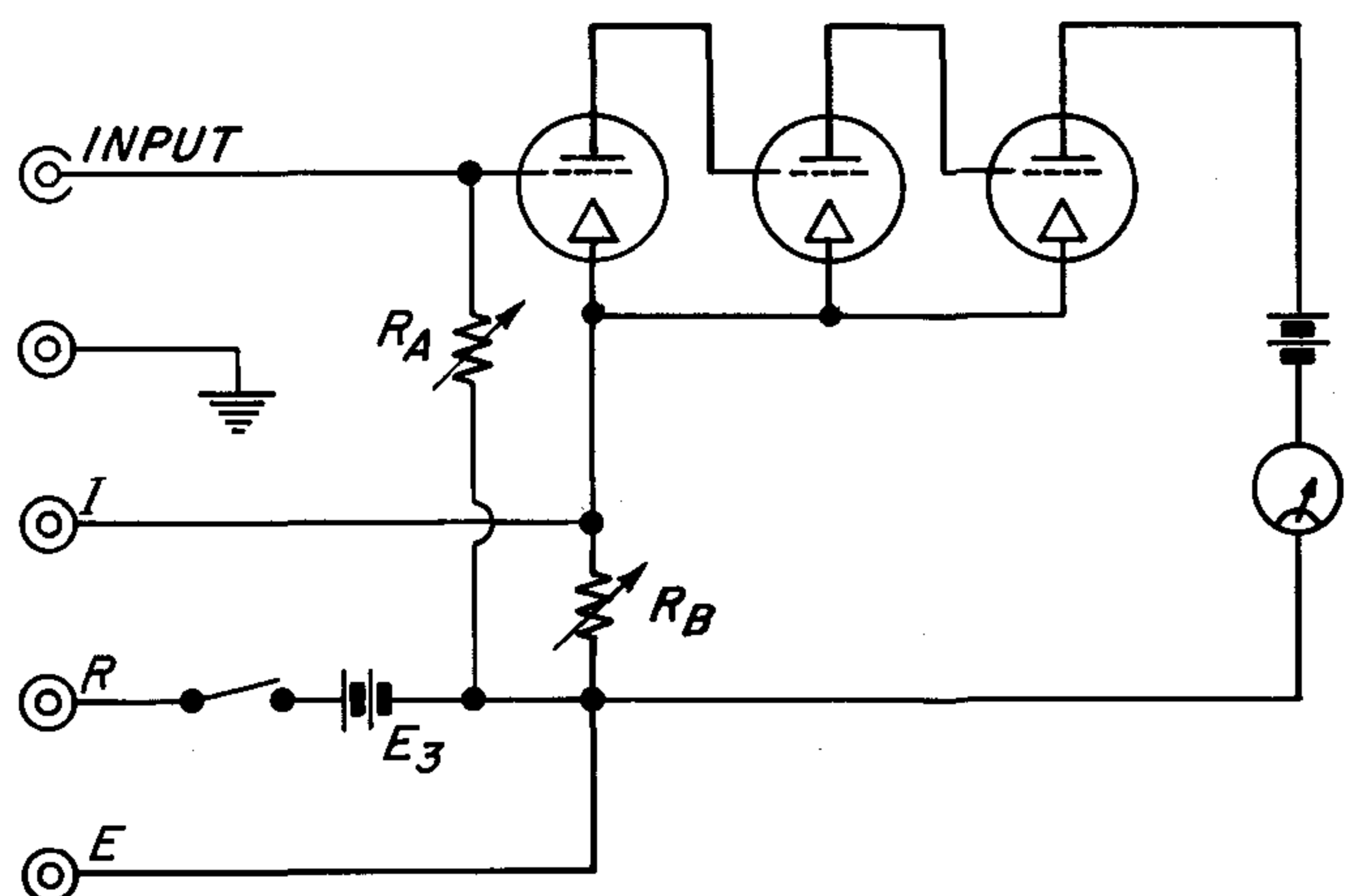

Figure 3. Guard-Point Arrangement.

2.4 OUTPUT CIRCUIT. The resistance of the recorder or other network at the output terminals can be as great as 1500 ohms with no effect on performance.

TYPE 1230-A D-C AMPLIFIER AND ELECTROMETER

2.5 GROUND AND GUARD. The unknown is usually connected from the high coaxial INPUT terminal to ground and the panel GROUND switch is set to R for resistance measurements, E for voltage measurements, and E or I for current measurements.

For measurement of three-terminal resistances or ungrounded resistances, a more flexible guard-ground system is desirable. To meet these situations, the Type 1230-A D-C Amplifier includes three guard terminals (I, R, and E), with provision for grounding any one of the three. Figure 3 shows the guard-point arrangement.

2.6 RESISTANCE STANDARDS CHECK. The 10^4 - and 10^5 -ohm resistance standards of the INPUT RESISTANCE switch are wire-wound and are accurate to within 0.25 percent. The other standards

are selected for high accuracy and stability, but resistors up to 10^{11} ohms are not yet available with 0.25-percent commercial tolerance. A simple checking system is included whereby any resistance standard R_A above 10^5 ohms can be quickly measured to a fair degree of accuracy in terms of the resistance standard two switch positions below it $\left(\frac{R_A}{100}\right)$. (Refer to paragraph 5.1.)

2.7 STABILITY. The instrument's high stability is largely due to the shock-mount construction adopted for the first two stages. To eliminate effects of line-voltage fluctuations, the voltage that supplies the grid-bias, filament-current, and screen-grid voltage of the first two amplifier tubes, as well as the plate voltage of the first tube, is carefully stabilized by means of two regulator stages.

Section 3

INSTALLATION

3.1 POWER SUPPLY. When connected to a 50-60-cycle power-line voltage as indicated on the plate below the power plug (115 or 230 volts), the Type 1230-A D-C Amplifier and Electrometer is ready for operation. If the instrument is not wired for the power-line voltage available, the fuses must be changed, the transformer terminals rewired (see Figure 15), and the plate at the power plug reversed to indicate the correct voltage.

3.2 RECORDER. Output terminals in series with the 0-5-ma meter allow the connection of a recorder, such as the General Radio Type 1521-A Graphic Level Recorder or the Esterline-Angus 0-5-ma or 0-1-ma Graphic Recorder. If the recorder sensitivity is greater than 5 ma, the recorder terminals can be shunted down so that the full-scale deflection is 5 ma. For example, if the Esterline-Angus 1-ma recorder is used, a 350-ohm shunt across the 1400-ohm recorder will reduce the sensitivity to 5 ma full scale. A 190-ohm shunt would be used with the Type 1521-A Graphic Level Recorder. While a simple shunt is usually satisfactory, the response time may be large because the recorder is overdamped. With the Esterline-Angus Recorder, a series-parallel shunt consisting of 5600 ohms directly in series with the 1400-ohm recorder, and 1750 ohms shunted across the series pair, reduces the response time from about 3 seconds to 1.2 seconds while maintaining the net load at the Type 1230-A OUTPUT terminals at 1400 ohms.

If the 1-ma recorder is not shunted, the effective sensitivity is increased by a factor of five (e.g. 6 mv full scale at a 30-mv setting). The only adverse effect is the corresponding magnification of noise and drift.

When the POLARITY switch is at minus, the negative (lower) OUTPUT terminal is connected to the E terminal through an internal choke coil. If the GROUND switch is at E, the negative OUTPUT terminal (and any recorder connected to it) is grounded.

3.3 SHIELDING OF UNKNOWN. Because the instrument is a high-resistance device, and sensitive to very small potentials, its INPUT terminal must be shielded from any source of unwanted potential if the INPUT RESISTANCE switch is at a high setting. Also, any change in capacitance at the input is accompanied by a proportional change in voltage, since charge is constant ($Q = CE$). This is evident if the input is connected by a flexible shielded cable; a slight mechanical disturbance of the cable can change its capacitance and hence its voltage enough to cause annoying surges. Similarly, if the input is unshielded and the resistance setting of the INPUT RESISTANCE control is set above 10^8 ohms, the change in meter reading caused by the waving of a charged polystyrene rod is quite evident, even if the rod is some distance from the instru-

ment. Experiments of this nature will soon convince the operator of the need for adequate, rigid shielding.

The Type 1230-P1 Component Shield provides excellent shielding, yet ready accessibility of components under measurement. It plugs directly into the coaxial INPUT terminal of the amplifier and includes connections to the various guard terminals. This accessory contains a small (4 by 5 inch) shelf. The cylindrical cover is easily removed.

A Type 1230-P1-300 Panel Connector is supplied with the amplifier so that the user can extend complete shielding to any size box required.

The Type 874-411 Adaptor, supplied with the amplifier, permits interconnection of the coaxial input terminal with banana plugs or binding posts. At low resistance levels, external shielding may not be required. At higher levels, partially enclosing the unknown may be sufficient.

Section 4 OPERATING PROCEDURE

4.1 PRELIMINARY SETTINGS.

4.1.1 Before turning the power ON, set the panel switch to 10 volts, push the ZERO (PUSH) switch in and rotate it slightly to lock it. With the switch in this position, the INPUT terminal is disconnected. Close the output circuit at the OUTPUT terminals either by using the Type 274-SB Shorting Bar supplied with the instrument or by connecting a recorder or other external circuit (of less than 1500 ohms). (Refer to paragraph 3.2.)

4.1.2 Turn the power switch from OFF to ON. The power switch has four positions for optimum switching sequence. In the first position, power is off and the meter-output circuit is open. In the second position, power is on, with the meter-output circuit still open. In the third position, the meter circuit is connected but is shunted. In the fourth (ON) position, the shunt is removed and the instrument is ready for operation. Although no damage will be caused if the instrument is turned on by external means without following the above switching sequences, the meter surge may be greater.

4.1.3 Set the meter zero by means of the COARSE and FINE ZERO controls. The zero setting is the same for all voltage ranges. For the most precise adjustment, set the zero with the range switch at 30 mv. Do not permit the meter to deflect off scale for any appreciable time.

4.1.4 During the first fifteen minutes or so, the meter zero may change several millivolts; it is easily reset to zero. Warm-up time may be greater if the amplifier has not been used for some time, or if it is enclosed in an Esterline-Angus case.

After warm-up, the zero may continue to drift, but the drift rate should not exceed 2 mv per hour; in most instruments it is less than 1 mv per hour. Drift will usually approach zero as operation time is increased.

4.1.5 When pushed, the ZERO (PUSH) switch opens the high INPUT terminal, but does not otherwise disturb either the "unknown circuit" or the amplifier circuit. To lock it in the position that disconnects the INPUT terminal; rotate the control after pushing it in. The control springs out and reconnects the INPUT terminal when rotated further and released. When connections to the INPUT terminals are to be changed, the INPUT terminal must be opened and the INPUT RESISTANCE switch must be set to zero. Otherwise, under some conditions, the amplifier will be subjected to a large voltage surge and may require an appreciable time for equilibrium to be established.

4.1.6 The ZERO (PUSH) switch is also used to disconnect the unknown and so to permit the checking and readjustment of the meter zero. A zero check and readjustment may be desirable if the final INPUT RESISTANCE switch setting is at 10^{11} ohms because of possible grid-current effects. An occasional zero check and readjustment may also be desirable when data are being recorded on the more sensitive ranges.

4.1.7 Set the POLARITY switch for the polarity of the input voltage or current at the high INPUT terminal (center terminal of the coaxial assembly). The POLARITY switch does not function when the MV-VOLTS-OHMS switch is at OHMS.

TYPE 1230-A D-C AMPLIFIER AND ELECTROMETER

4.2 VOLTAGE MEASUREMENTS.

- a. Set the GROUND switch to E.
- b. Set the MV-VOLTS-OHMS switch to 10 volts.
- c. Connect the unknown voltage source from high INPUT to ground.
- d. Set the INPUT RESISTANCE switch to the desired value and release the ZERO (PUSH) button.
- e. Reset the MV-VOLTS-OHMS switch as necessary and operate the POLARITY switch to obtain a voltage reading on the meter. The appropriate meter scale is indicated by the final setting of the MV-VOLTS-OHMS switch.

4.3 CURRENT MEASUREMENTS. There are two methods of measuring current with the Type 1230-A D-C Amplifier and Electrometer, as described in the following paragraphs.

First Method. Connect the unknown-current source from the high INPUT terminal to ground and set the GROUND switch to E. The unknown current flows through the input resistance R_A and the voltage drop across it is indicated on the meter. The unknown current is equal to the indicated voltage E divided by the input resistance R_A . (See Figure 4a.)

$$I_x = \frac{E}{R_A}$$

Since this is essentially a voltage measurement, adjustments and connections are as outlined in paragraph 4.2. A method that provides a lower effective ammeter resistance is described in the next paragraph.

Second Method. Adjust the zero controls for an exact meter zero. Connect the unknown current

source from the high INPUT terminal to ground. Set the GROUND switch to I. The unknown current is:

$$I_x = \frac{E}{R_A + R_B}$$

When the unknown current is less than $30 \mu\text{a}$, the simpler equation can be used:

$$I_x = \frac{E}{R_A}$$

The connections are as shown in Figure 4b, and the effective ammeter resistance (R_{eff}) is small compared with R_A , the panel switch setting of INPUT RESISTANCE.

$$R_{\text{eff}} \approx \frac{R_A}{G_m R_B}$$

For typical transconductance (G_m) of 33 mhos,

$$R_{\text{eff}} \approx \frac{0.03R_A}{R_B}$$

The value of R_B is a function of the setting of the MV-VOLTS-OHMS switch as tabulated below:

Switch Setting	R_B
30 mv	6 ohms
100 mv	20 ohms
300 mv	60 ohms
1 v	200 ohms
3 v	600 ohms
10 v	2000 ohms

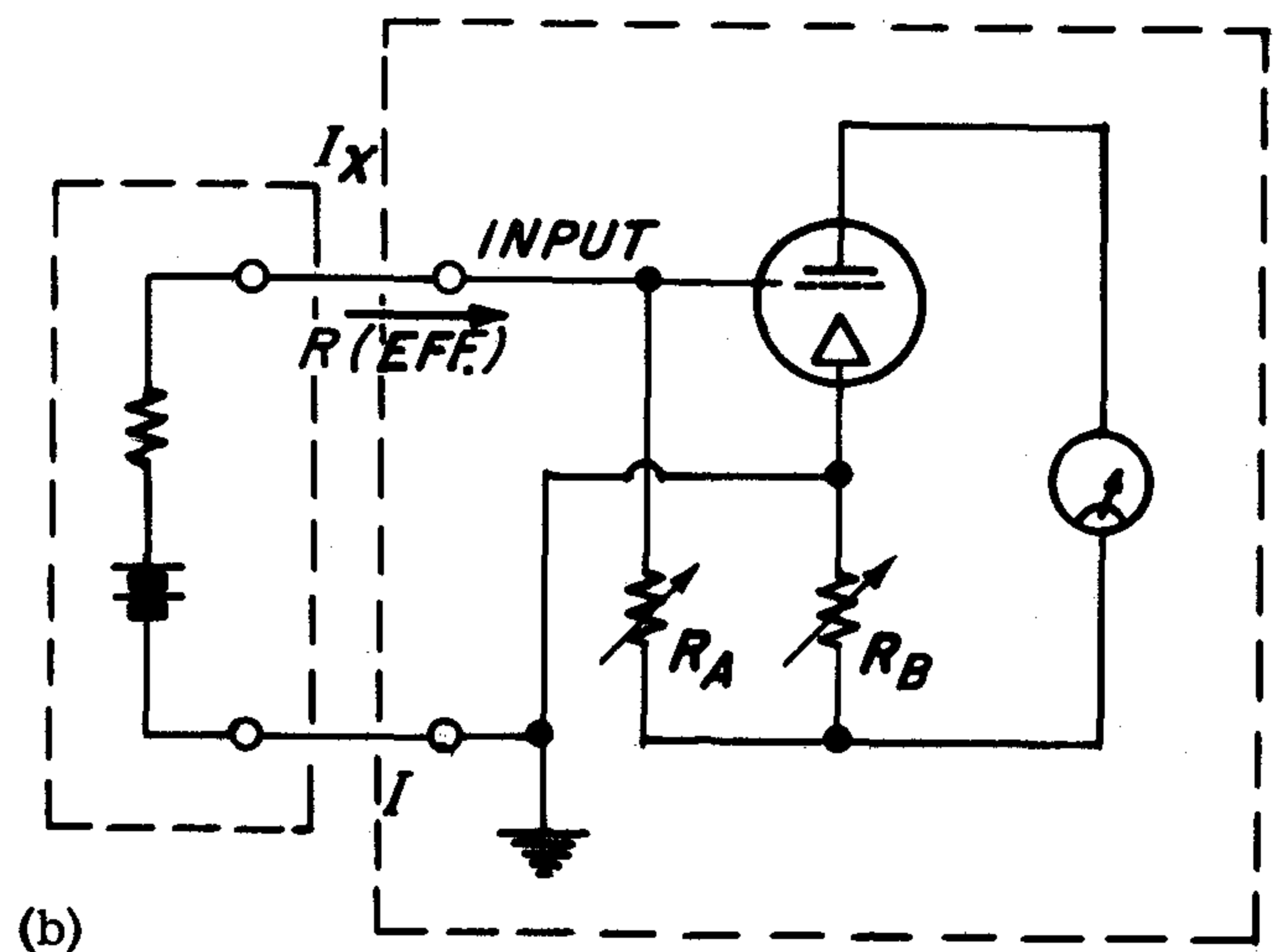
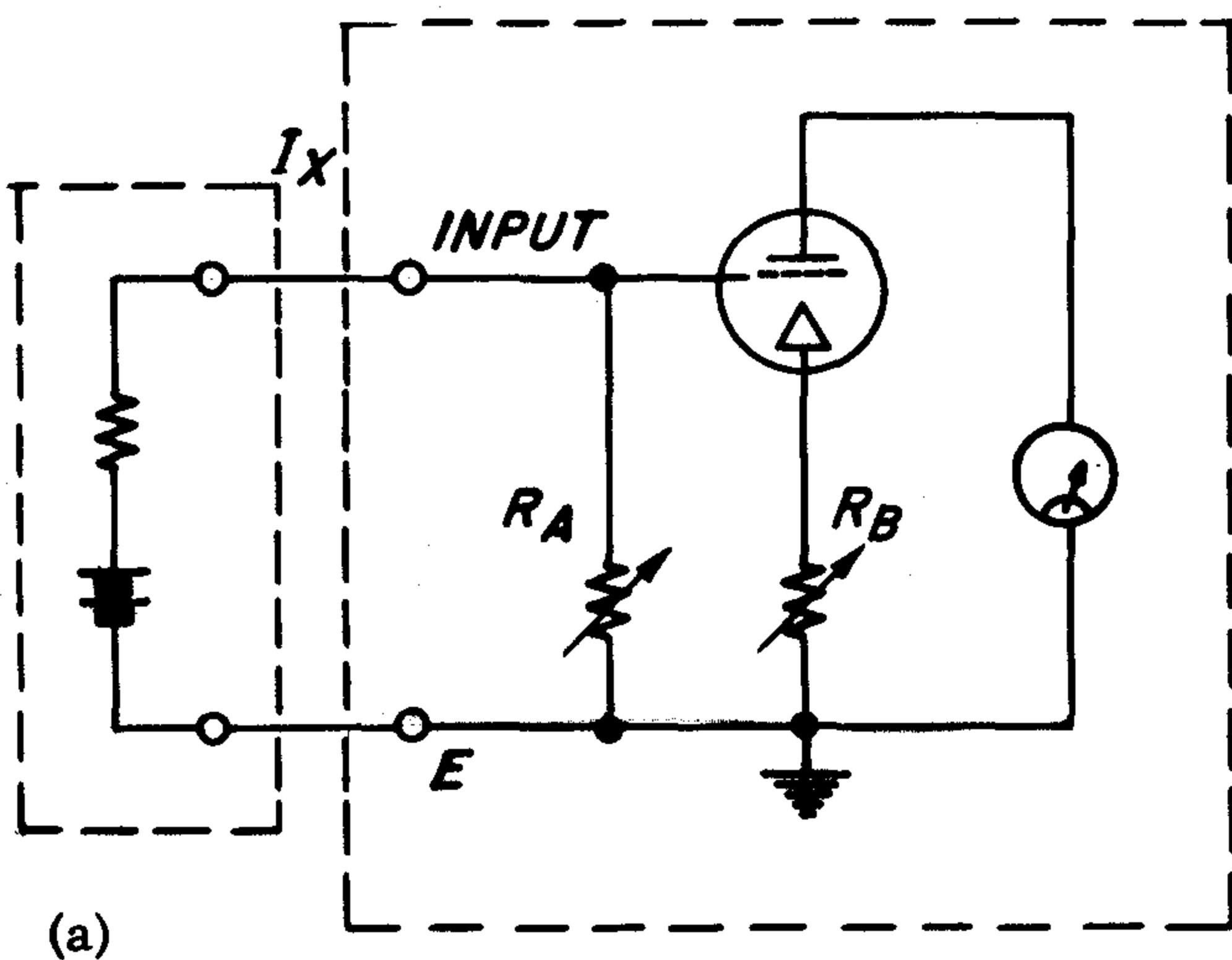

Figure 4. Alternate Methods for Current Measurement.

GENERAL RADIO COMPANY

An interesting result is that the effective input resistance does not change substantially if the R_A switch is changed by a given factor and the MV-VOLTS-OHMS switch (R_B) is changed by the same

factor in the same direction. For accurate results, the resistance of the unknown-current source should be greater than the value (in ohms) tabulated below:

R_A	VOLTS RANGE					
	30 MV	100 MV	300 MV	1 V	3 V	10 V
10^4	10^4	2×10^3	5×10^2	2×10^2	5×10	1.5
10^5	10^5	2×10^4	5×10^3	2×10^3	5×10^2	1.5×10
10^6	10^6	2×10^5	5×10^4	2×10^4	5×10^3	1.5×10^2
10^7	10^7	2×10^6	5×10^5	2×10^5	5×10^4	1.5×10^3
10^8	10^8	2×10^7	5×10^6	2×10^6	5×10^5	1.5×10^4
10^9	10^9	2×10^8	5×10^7	2×10^7	5×10^6	1.5×10^5
10^{10}	10^{10}	2×10^9	5×10^8	2×10^8	5×10^7	1.5×10^6
10^{11}	10^{11}	2×10^{10}	5×10^9	2×10^9	5×10^8	1.5×10^7

Note from Figure 4b that the unknown source resistance and R_A form a potential divider across the degenerative resistor R_B ; consequently, if the source resistance is small compared to R_A , the effective degeneration is decreased, and the tendency to instability is increased, particularly at the most sensitive range; that is why the zero controls must be set for an exact meter zero.

If the unknown source has appreciable capacitance, operate the instrument for a few seconds at the 10-volt range and at a low value of INPUT RESISTANCE (R_A) to avoid any initial instability.

If the unknown source contains an a-c component, the a-c source impedance may be small compared to R_A , and the a-c component may not then be sufficiently degenerated, with consequent instability. In spite of these limitations, the method is useful in many applications.

4.4 RESISTANCE MEASUREMENTS WITH INTERNAL D-C SUPPLY.

a. Set the INPUT RESISTANCE OR OHMS MULTIPLIER switch to zero.

b. Set the MV-VOLTS-OHMS switch to 90 ohms, and adjust the zero control knobs for meter zero (∞ on resistance scales). The POLARITY switch does not function when the MV-VOLTS-OHMS switch is at an OHMS setting, as the low side of the unknown resistance is connected to the positive terminal of the internal 9.1-volt source.

c. Set the GROUND switch as follows:

(1) If the unknown resistance is grounded, connect it from the high INPUT terminal to the adjacent ground terminal and set the GROUND switch

to R. (See Figure 5.) Instrument leakage from INPUT to ground (about 10^{14} ohms) will be across the unknown, and therefore may affect the final reading. The actual leakage value can be determined by a preliminary measurement with the unknown resistance R_x disconnected.

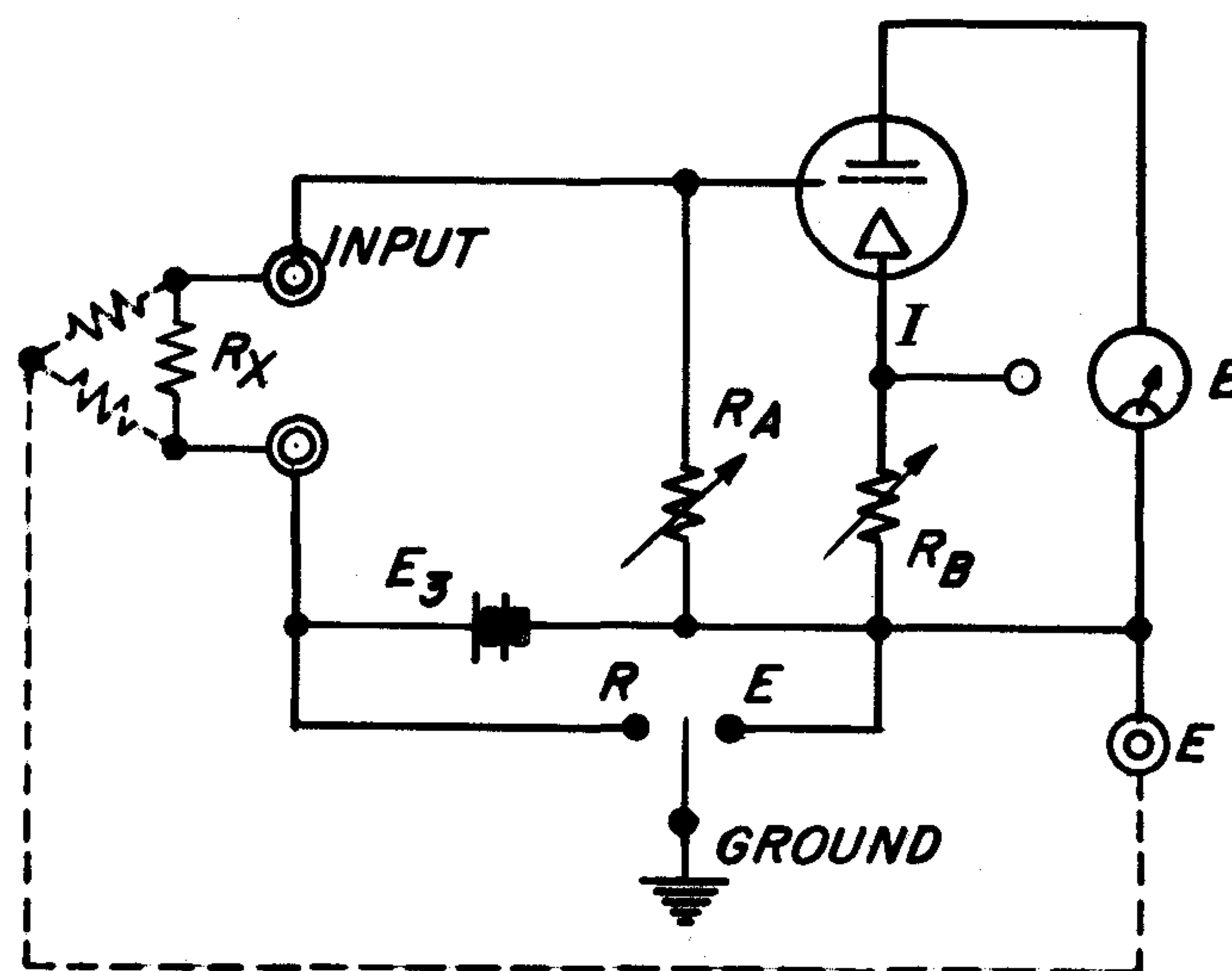

Figure 5. Resistance Measurement with Internal D-C Supply.

(2) If the unknown resistance is not grounded, and especially if small high-resistance components (that need not be grounded) are to be measured, connect the unknown from the high INPUT terminal to the R terminal and set the GROUND switch to E (see Figure 5). Instrument leakage will be across the internal resistance standard R_A and will not introduce any error. Leakage across the unknown will be nonexistent.

TYPE 1230-A D-C AMPLIFIER AND ELECTROMETER

(3) If the unknown resistance is a three-terminal resistance, (shown dotted in Figure 5), connect the third terminal to the E terminal. Connect the other two terminals in accordance with (1) and (2) above.

d. Advance the OHMS MULTIPLIER switch to a setting at which the meter reads upscale. Select between the 90-ohm and 30-ohm positions of the function switch for the higher meter deflection.

e. The unknown resistance in ohms is indicated on the appropriate OHMS scale of the meter as multiplied by the OHMS MULTIPLIER. Use the ∞ to 90 scale if the OHMS switch is at 90 ohms, the ∞ to 30 scale if the OHMS switch is at 30 ohms.

f. The voltage across the unknown is from 8.8 to 9.1 volts.

g. At full scale, the voltage across the standard R_A is 100 mv for the 90-ohm scale and 300 mv for the 30-ohm scale.

4.5 RESISTANCE MEASUREMENTS WITH EXTERNAL D-C SUPPLY.

4.5.1 CONDITIONS OF MEASUREMENT. The external supply must be either batteries or a stabilized line-operated supply. See Figure 6.

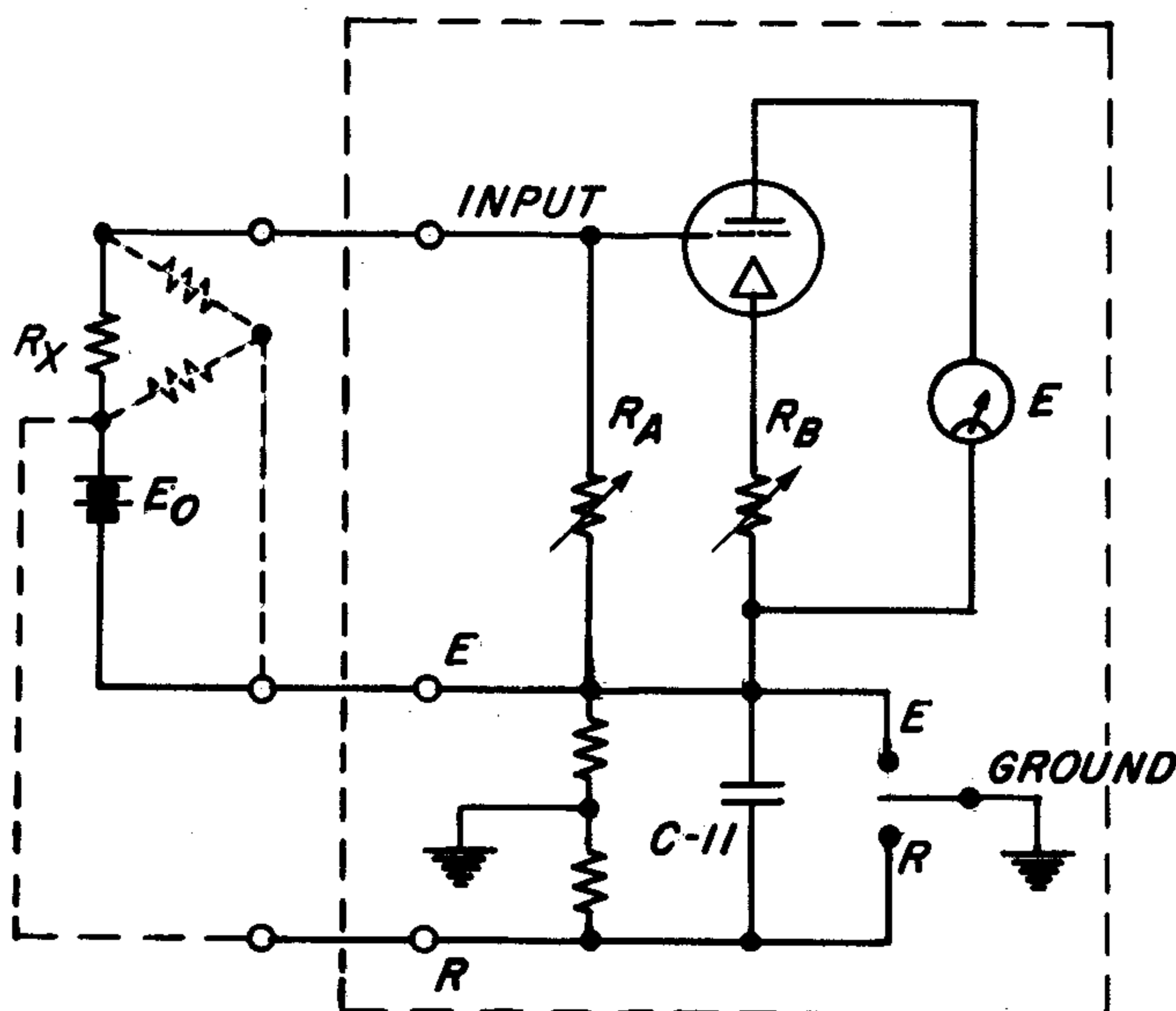

Figure 6. Resistance Measurement with External D-C Supply.

Since the supply is external, the Type 1230-A Amplifier merely measures the voltage drop across the resistance standard R_A .

If the unknown resistance need not be grounded, the voltage of the external supply is not limited by the amplifier design. If the unknown must be grounded, the voltage of the external supply is lim-

ited to the 600-volt rating of C11 (Figure 6), a capacitor in the instrument. The unknown resistance must be capable of withstanding the full voltage of the supply.

The unknown resistance is normally calculated from the voltage indication of the Type 1230-A Amplifier. If the external supply is 90 volts, the OHMS scale (with an additional multiplying factor of ten) may be used with an acceptable degree of accuracy.

4.5.2 MEASUREMENT PROCEDURE.

a. Set the OHMS MULTIPLIER switch to zero. Set the MV-VOLTS-OHMS function switch to 30 MV to adjust the zero control knobs for meter zero. Reset the function switch to 10 volts.

b. Set the GROUND switch to R if the unknown is to be grounded, to E if the unknown is not to be grounded. In either case, note from Figure 6 that the external supply will be grounded. If the unknown resistance is grounded, instrument leakage from input to ground (about 10^{14} ohms) will be across the unknown and therefore may affect the final reading. The actual leakage value can be determined from a preliminary measurement with the unknown resistance disconnected.

If the unknown resistance is to be ungrounded (preferable in measurement of small components), amplifier leakage will be across the internal resistance standard R_A and will not introduce an error. There will be no leakage across the unknown if due care is taken when connections are made.

c. Connect one end of the unknown resistance to the high INPUT terminal, and connect the other end to one terminal of the external d-c supply. Connect the other terminal of the d-c supply (preferably the positive terminal) to the E terminal of the amplifier.

d. If the unknown resistance is to be grounded, connect the junction of the external d-c supply and the unknown resistance to the R terminal or to the ground terminal. If the unknown is a three-terminal resistance (shown dotted in Figure 6) connect the third terminal to the E terminal.

e. Advance the OHMS MULTIPLIER switch until the meter reads upscale, reducing the VOLTS switch setting if necessary. The unknown resistance in ohms is the ratio of the external voltage E_0 to the indicated meter voltage E multiplied by the OHMS MULTIPLIER setting:

$$R_x = \frac{E_0}{E} R_A - R_A$$

When E is much smaller than E_0 , $R_x \approx \frac{E_0 R_A}{E}$.

Note that E in the equation must be expressed in volts rather than in millivolts.

f. The voltage across the unknown is:

$$E_x = E_0 - E$$

4.6 MEASUREMENT OF CAPACITOR LEAKAGE RESISTANCE.

4.6.1 The leakage resistance of a capacitor is measured in the same manner as any other resistance. However, because the capacitance introduces a time factor, there are additional considerations necessary for accurate results.

The resistance-measurement method is basically a current measurement. The voltage drop in the resistance standard is a function of the current in the unknown. When the unknown has capacitance, the current is at first chiefly the charging current, the leakage-current component being negligible. Eventually, when the capacitor is fully charged, the only current flowing is that due to leakage resistance. The time required to charge the capacitor depends to some extent on the series resistance of the circuit (resistance standard), but to a much greater extent on the dielectric properties of the capacitor and the relative magnitude of the leakage.

Consider for example, the circuit shown in Figure 7. The capacitor C_x will have absorbed about two thirds of its final charge from E_0 in a time determined by the $R_A C_x$ product if there is no appreciable dielectric absorption. This is true of air capacitors. For most dielectrics, the time necessary for the capacitor to absorb the charge is much greater than the $R_A C_x$ product because of interfacial polarization. Consequently, when a potential is applied to a capacitor, the time required for a complete charge can be a matter of seconds, hours, or even days, depending on the dielectric and on the leakage.

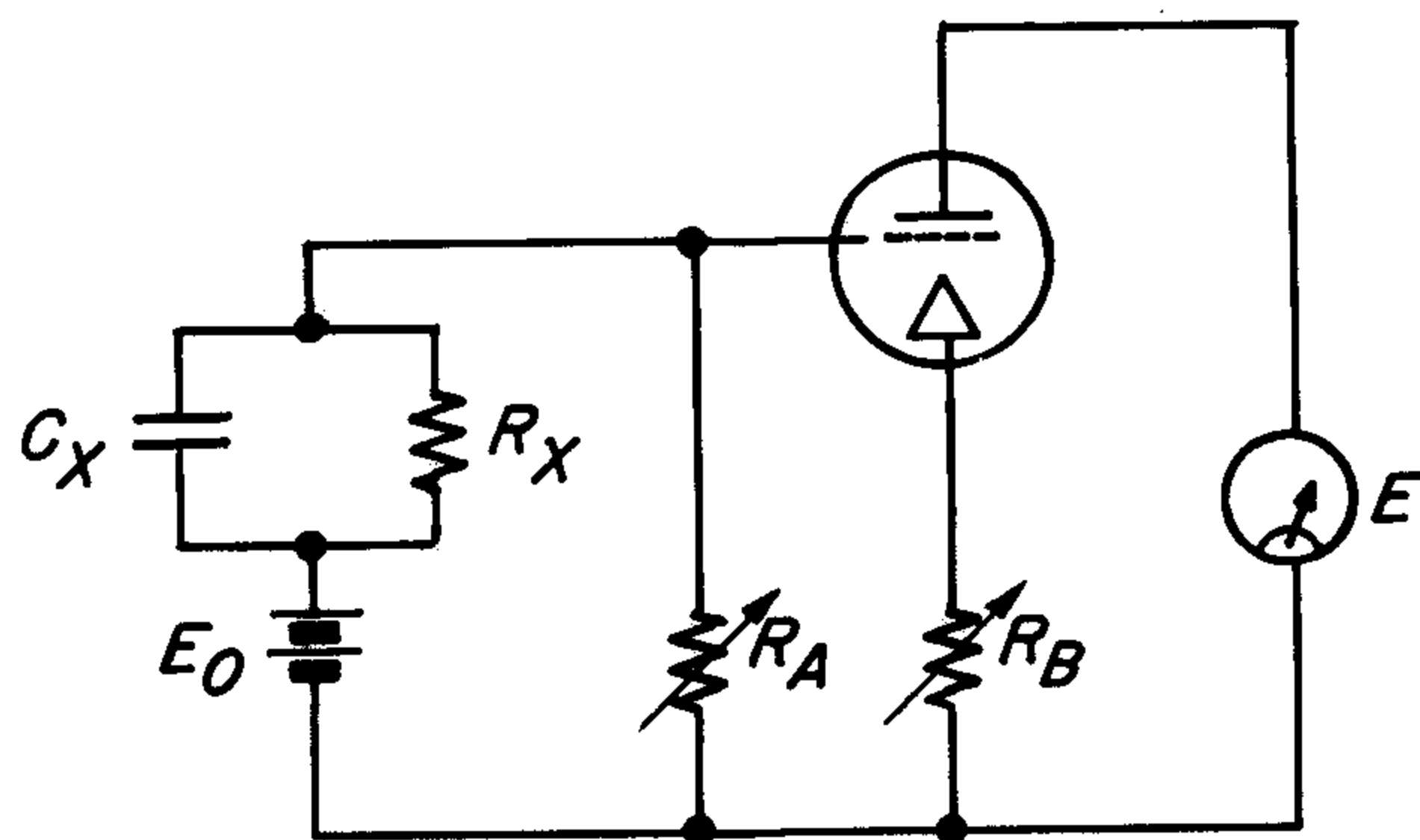

Figure 7. Capacitor Leakage-Resistance Measurement.

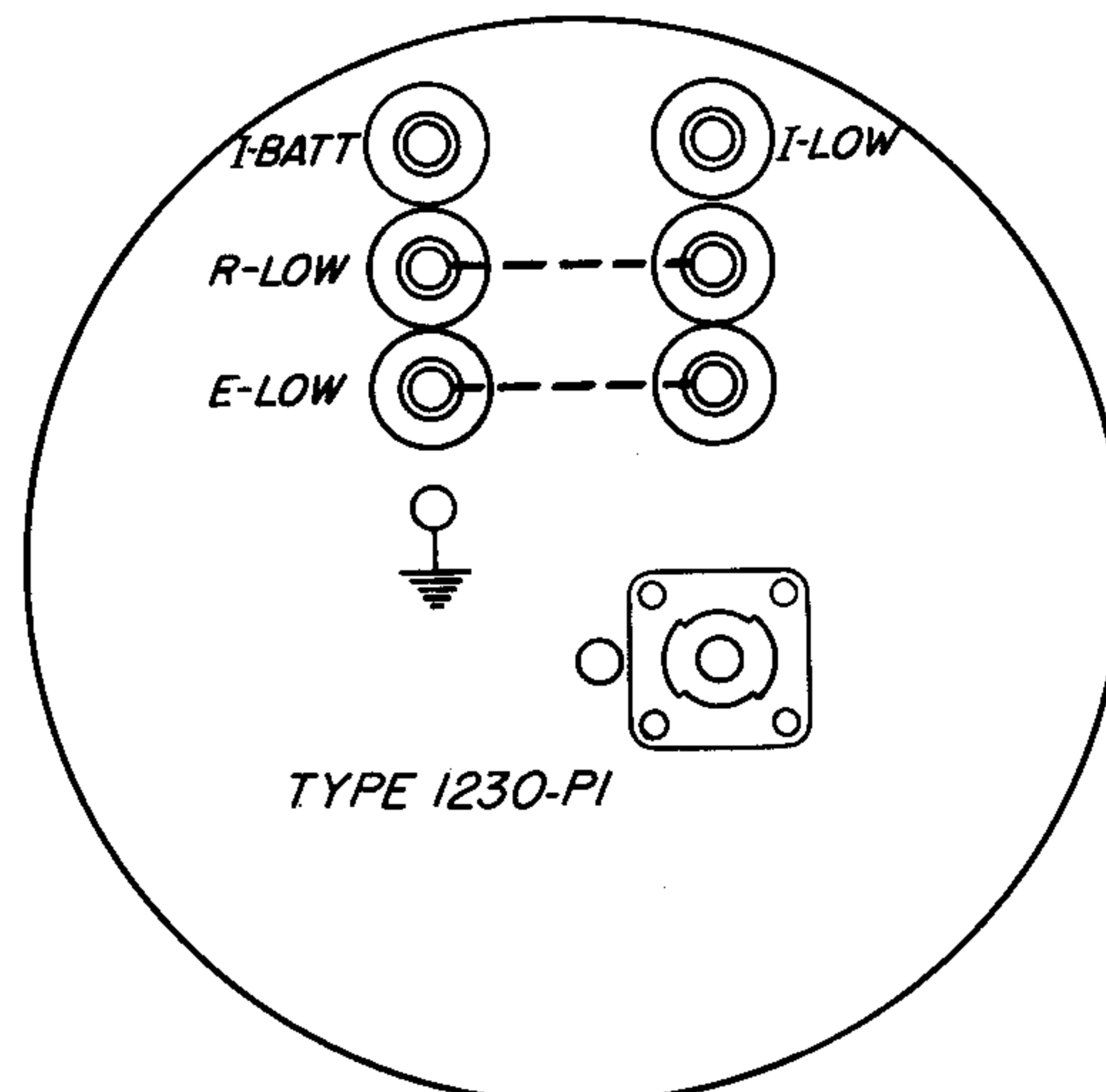

Figure 8. Type 1230-P1 Component Shield, Showing Wiring of Terminals.

To determine the component of current due to leakage, it is not necessary to wait until the capacitor is fully charged; it is necessary to wait only until the meter reading attains a constant value. The greater the leakage, the sooner the final determination can be made.

4.6.2 When measuring the leakage resistance of a capacitor (see Figure 7), start with the OHMS MULTIPLIER switch (R_A) at zero. With the function switch at either 30 MV (with an external d-c supply) or 90 OHMS (internal supply), advance the OHMS MULTIPLIER switch to obtain a meter reading. Monitor the meter reading until it has decreased to a steady value, that is, until the decreasing charge current is small compared with the leakage current. While the charging current is still appreciable, a change in the OHMS MULTIPLIER setting will, for a short time (about $R_A C_x$ seconds), upset the rate at which the meter reading approaches an equilibrium value.

If a resistance limit, rather than the absolute value of resistance, is being sought, the meter reading need be monitored only until it attains the limit.

4.6.3 Charge currents and discharge currents of capacitors, as well as recovery voltage after short-circuit, can be recorded, providing valuable information for the determination of dielectric relaxation frequencies, very-low-frequency dielectric constant, and dissipation factor behavior.^{1,2}

¹Field, Robert F., "The Basis for the Nondestructive Testing of Insulation", AIEE Transactions, September, 1941.

²Von Hippel, A., "Dielectric Materials and Applications", MIT Technology Press and John Wiley Co., 1954, pages 52-54.

TYPE 1230-A D-C AMPLIFIER AND ELECTROMETER

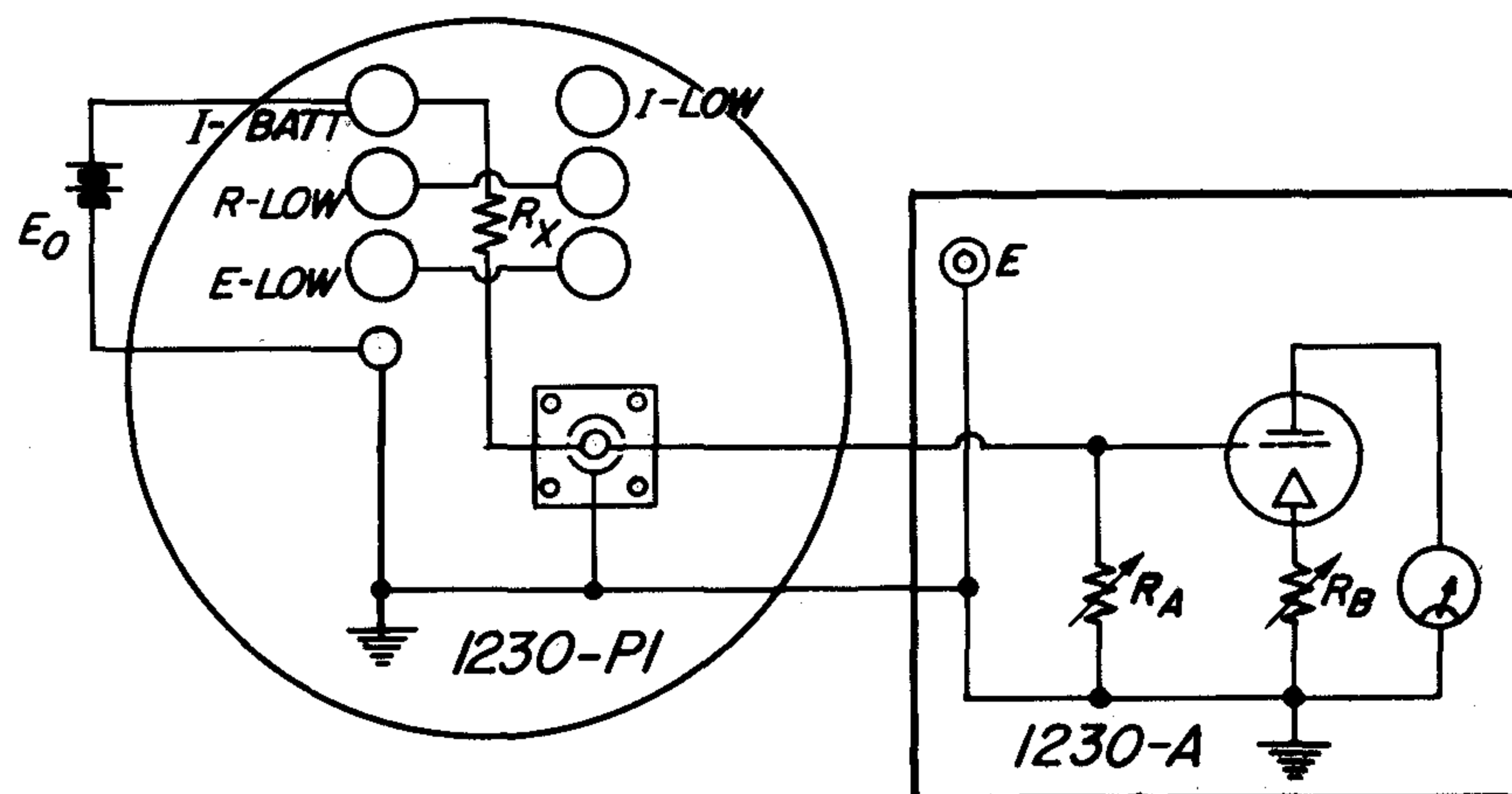

Figure 9. Setup for Measurement of a Resistor in the Shielded Compartment, with External Voltage up to 5000 Volts.

4.7 TYPE 1230-P1 COMPONENT SHIELD. This unit is an extension of the terminal system of the amplifier into a completely shielded, yet readily accessible compartment. The I-, R-, and E- LOW terminals are brought out to facilitate connections to external power sources. The shield is especially useful in measurement of the small components (resistors, capacitors, back resistance of silicon diodes, etc) at a level above 10^8 ohms. A shelf is included on the panel of the unit.

The wiring of the Type 1230-P1 Component Shield is shown in Figure 8. The E-LOW and R-LOW terminals are wired for easy access. The I-LOW terminal may be connected to the I-BATT terminal for external access. The I-LOW terminal is supplied unwired to permit use of the I-BATT terminal in those applications where R_x is ungrounded and external battery voltage exceeds 600 volts. The connections are shown in Figure 9.

4.8 HIGH-VOLTAGE MEASUREMENTS. Voltage measurements up to the kilovolt range can be made with the Type 1230-A Amplifier when an external resistance standard R_x is used. See Figure 10.

$$E_x = \frac{R_x + R_A}{R_A} E_2 \approx \frac{R_x}{R_A} E_2$$

Thus, when R_x is 10^{12} ohms and R_A is set to 10^8 ohms, E will be 3 volts for an E_x of 30 kv. External resistance standards of adequate accuracy are available to 10^{11} at 125 kv, to 10^{14} at 15 kv.

If the unknown voltage does not exceed 5 kv, the standard (R_x) can be mounted in the Type 1230-P1 Shield (HIGH to I-BATT); the unknown voltage is then connected from the I-BATT terminal to ground. See Figure 9.

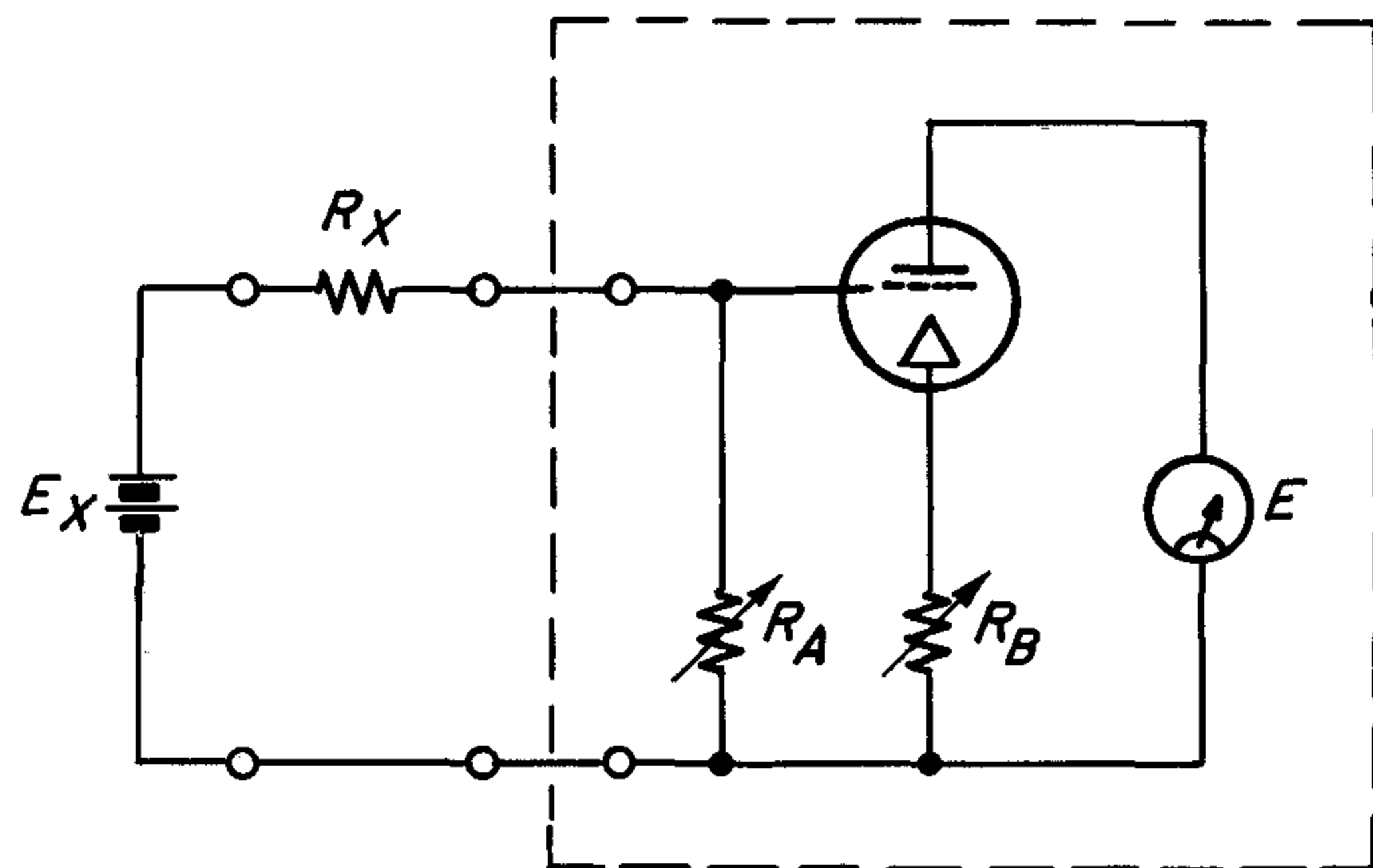

Figure 10. Connection for Measuring High Unknown Voltage.

CHECKS AND ADJUSTMENTS

5.1 CHECKING INTERNAL RESISTANCE STANDARDS. When the MV-VOLTS-OHMS switch is set in the CHECK position, the instrument indicates the resistance of any higher RESISTANCE MULTIPLIER standard. This indication is given on the 90 OHMS scale. (See Figure 11.) The resistance of the standard, R_A , is given in terms of the standard two steps below it ($\frac{R_A}{100}$). The lower-resistance standards (10^4 ohms and 10^5 ohms) are wire-wound resistors, accurate to ± 0.25 percent. Since the meter reading is near full scale, the higher standards can be checked with a considerable degree of accuracy. A single measurement is sufficient to determine the correct value of either the 10^6 -ohm or 10^7 -ohm standard. Two measurements are required to determine the value of either the 10^8 -ohm or 10^9 -ohm standard. (For instance, the 10^9 -ohm standard is measured in terms of the 10^7 -ohm standard, and the 10^7 -ohm standard is in turn measured in terms of the 10^5 -ohm standard.) Three measurements are necessary to determine the value of either the 10^{10} -ohm or 10^{11} -ohm standard. The preliminary zero setting, which is ∞ on the OHMS scale, should be made with the INPUT RESISTANCE OR OHMS MULTIPLIER switch set at 10^5 ohms for greatest accuracy. The GROUND switch may be set at any of its three positions. Lock the ZERO (PUSH) in to open the INPUT terminal.

5.2 AUXILIARY ZERO CONTROL. Normally, the two ZERO controls on the panel of the instrument are sufficient to obtain a zero setting. However, if tubes have been changed, or if the instrument has seen considerable service, the panel ZERO controls may not be adequate. In such an instance, the auxiliary zero control (R26, see Figure 13) can be adjusted to bring zero within the range of the panel controls. The auxiliary zero control is inside the cabinet, on the shelf, to the left of the meter. This control can be set by means of a long-handled

screw driver, without requiring removal of the cabinet.

5.3 INTERNAL VOLTAGE ADJUSTMENT. A highly stabilized voltage supply of 9.10 volts is built into the instrument for the measurement of unknown resistances. This built-in voltage can be measured and adjusted by the following procedure:

- Set the MV-VOLTS-OHMS switch to 90 OHMS.
- Push in the ZERO switch, and connect a high-resistance voltmeter from the E terminal to the R terminal. The meter resistance must be greater than 2 megohms.
- If the voltage is not exactly 9.10 volts, set it to this value by adjusting R33 (see Figure 12), which is located inside the cabinet, on the shelf, to the right of the meter. This control can be adjusted by means of a long-handled screw driver, without requiring removal of the cabinet.

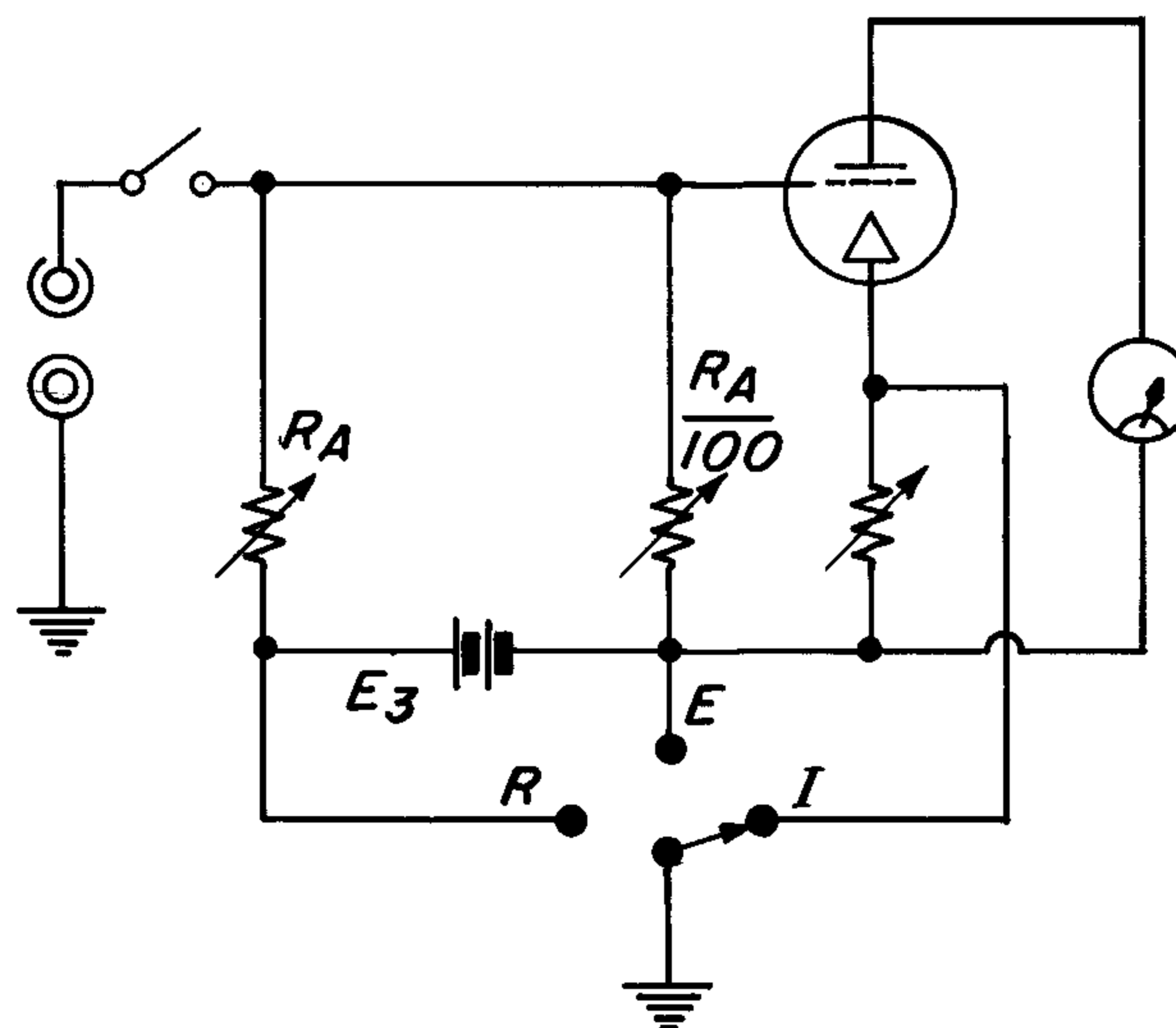

Figure 11. Check on Internal Resistance Standard.

Section 6

SERVICE AND MAINTENANCE

6.1 GENERAL. The two-year warranty given with every General Radio instrument attests the quality of materials and workmanship in our products. When difficulties do occur, our service engineers will assist in any way possible.

In case of difficulties that cannot be eliminated by the use of these service instructions, please write or phone our Service Department, giving full information of the trouble and of steps taken to remedy it. Be sure to mention the serial and type numbers of the instrument.

Before returning an instrument to General Radio for service, please write to our Service Department or nearest district office (see back cover), requesting a Returned Material Tag. Use of this tag will insure proper handling and identification. For instruments not covered by the warranty, a purchase order should be forwarded to avoid unnecessary delay.

6.2 REMOVAL OF CABINET. Remove the two screws from the top of the instrument, and the four feet from the bottom. Slide the cabinet away from the panel. Tubes, adjustments, and most components are now accessible.

6.3 TUBE REPLACEMENT AND ADJUSTMENT. If V1 is replaced, R26 may require adjustment (paragraph 5.2). Any excessive grid current or meter drift will diminish if the instrument is operated for several hours to age the new tube. To measure grid current, note the increase in meter reading at the +30 MV range with the INPUT RESISTANCE switch at 10^{11} ohms. A 2-mv increase is normal.

To extract V1 or V2 from its socket, use a No. 14 or No. 12 wire, bent at a right angle 1/2

inch from the end, as a tool to pull out the leads simultaneously.

V1 has four leads adjacent to the red dot. Cut these to 7/16 inch and bend them at right angles. The fifth lead is the grid lead. Do not cut it; if possible, treat the glass around it with GE Dri-Film SC-87 to eliminate leakage in high humidity.

The leads of a replacement tube V2 should be cut to 7/16 inch and bent. Replacement of V2, V3, V5, V6, V7 or V8 should not require component re-adjustment.

6.4 OPENING THE INSTRUMENT. After the cabinet is removed, the instrument can be further opened out as follows:

a. Unsolder the lead from the rear of the INPUT RESISTANCE switch to the anchor terminal that mounts R10.

b. Remove the two 5/16-inch hex-head screws from the front panel and the three hex-head screws from the rear panel. Keep the teflon insulation free from dirt.

When reassembling, make sure the ZERO (PUSH) switch functions properly and that the lead from the INPUT RESISTANCE switch to the R10 anchor terminal is resoldered. If the contacts of the INPUT RESISTANCE switch or of the MV-VOLTS-OHMS switch (mounted on teflon bushings) need lubrication, use as little lubricant as possible to avoid smearing insulation.

6.5 VOLTAGE AND RESISTANCE CHART. The following table gives normal d-c voltages and resistances from tube socket pins to ground.

TUBE (TYPE)	PIN	VOLTS TO GND	RES TO GND	TUBE (TYPE)	PIN	VOLTS TO GND	RES TO GND	TUBE (TYPE)	PIN	VOLTS TO GND	RES TO GND	
V1 (5886)	1	11.2	15 M	V3 (6AN5)	6	216	14 k	V6 (OB2)	4	108		
	2	**	16 k		7	100	28 k		5	216	14 k	
	3	3.5	410						7	108		
	4	2.3	380		V4 (6627)	1	108	9 k	V7 (OB2)	1	108	28 k
	7		10 M			2	0	200		2	0	200
V2 (CK6418)	1	100	2.8 M	4	0	200	4	0		200		
	2	58	4800	5	108	9 k	5	108		28 k		
	3	18	1600	7	0	200	7	0		200		
	4	14.2	15 M*	V5 (OB2)	1	108	200	V8 (6AL5)	1	108	11 k	
	5	17	1600		2	0	200		2	108	28 k	
V3 (6AN5)	1	100	2.8 M		4	0	200		3	2.3		
	2	100	28 k	5	108	200	4		2.3			
	3	2.3		7	0	200	5		108	11 k		
	4	2.2		V6 (OB2)	1	216	14 k	7	108	28 k		
	5	260*	51 k		2	108						

NOTES: * Measured with vacuum-tube voltmeter.
 ** 4.6 to 7.4 v, depending on zero set.
 † 14 to 19 k, depending on zero set.

Switch Settings: OHMS MULTIPLIER at 10^4
 VOLTS at 1
 Ground at E

Measurements made with 20,000-ohm-per-volt multimeter.

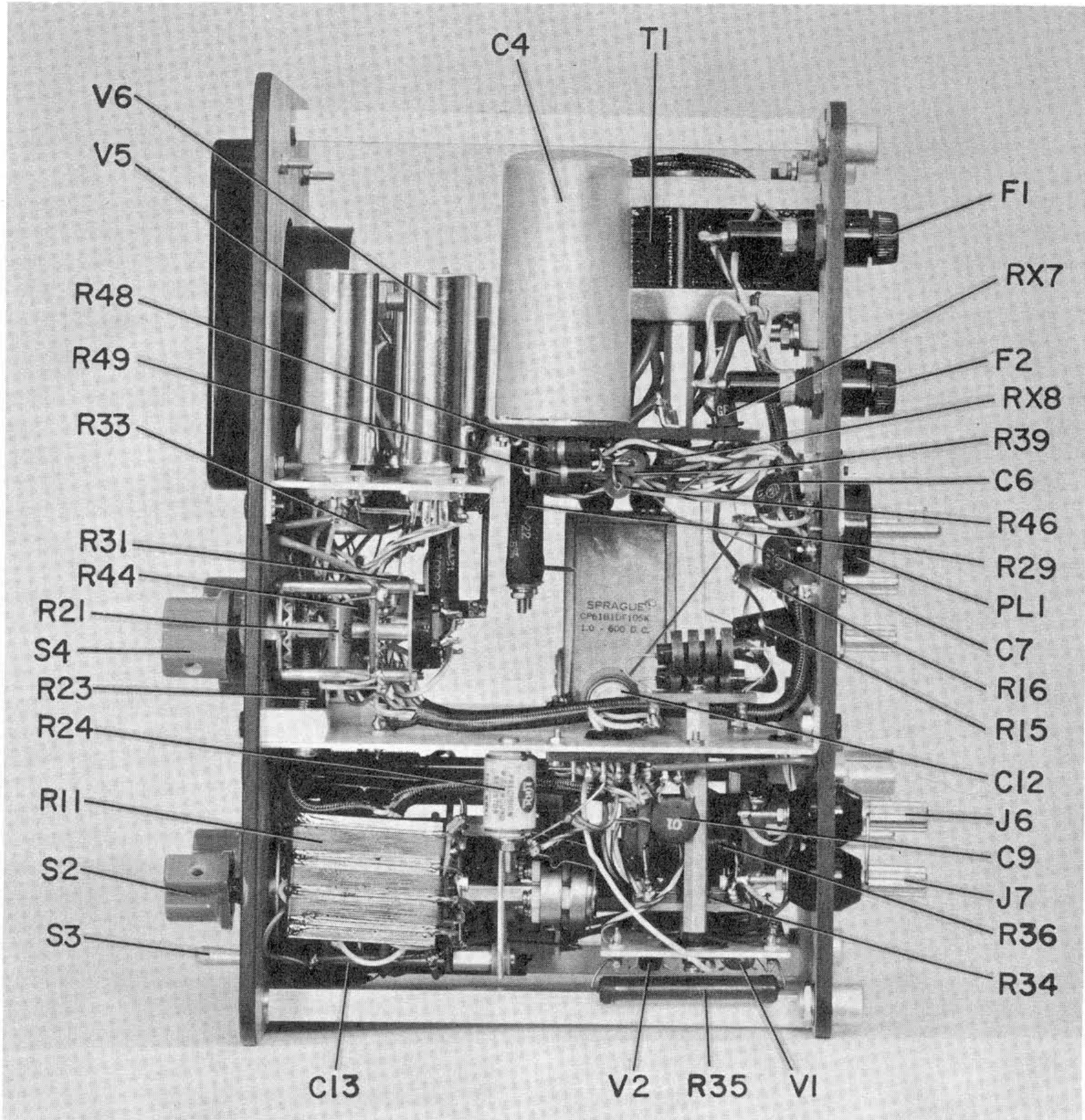
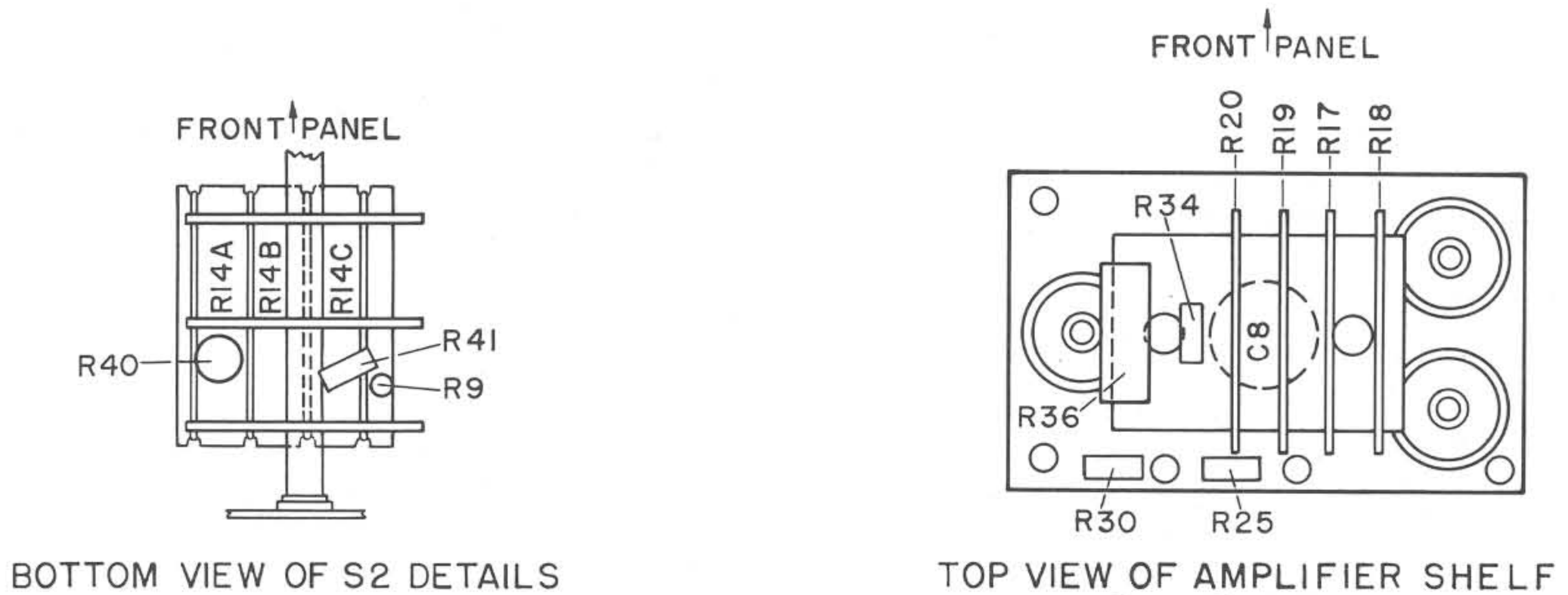

Figure 12. Interior View of Type 1230-A D-C Amplifier and Electrometer.



TYPE 1230-A D-C AMPLIFIER AND ELECTROMETER

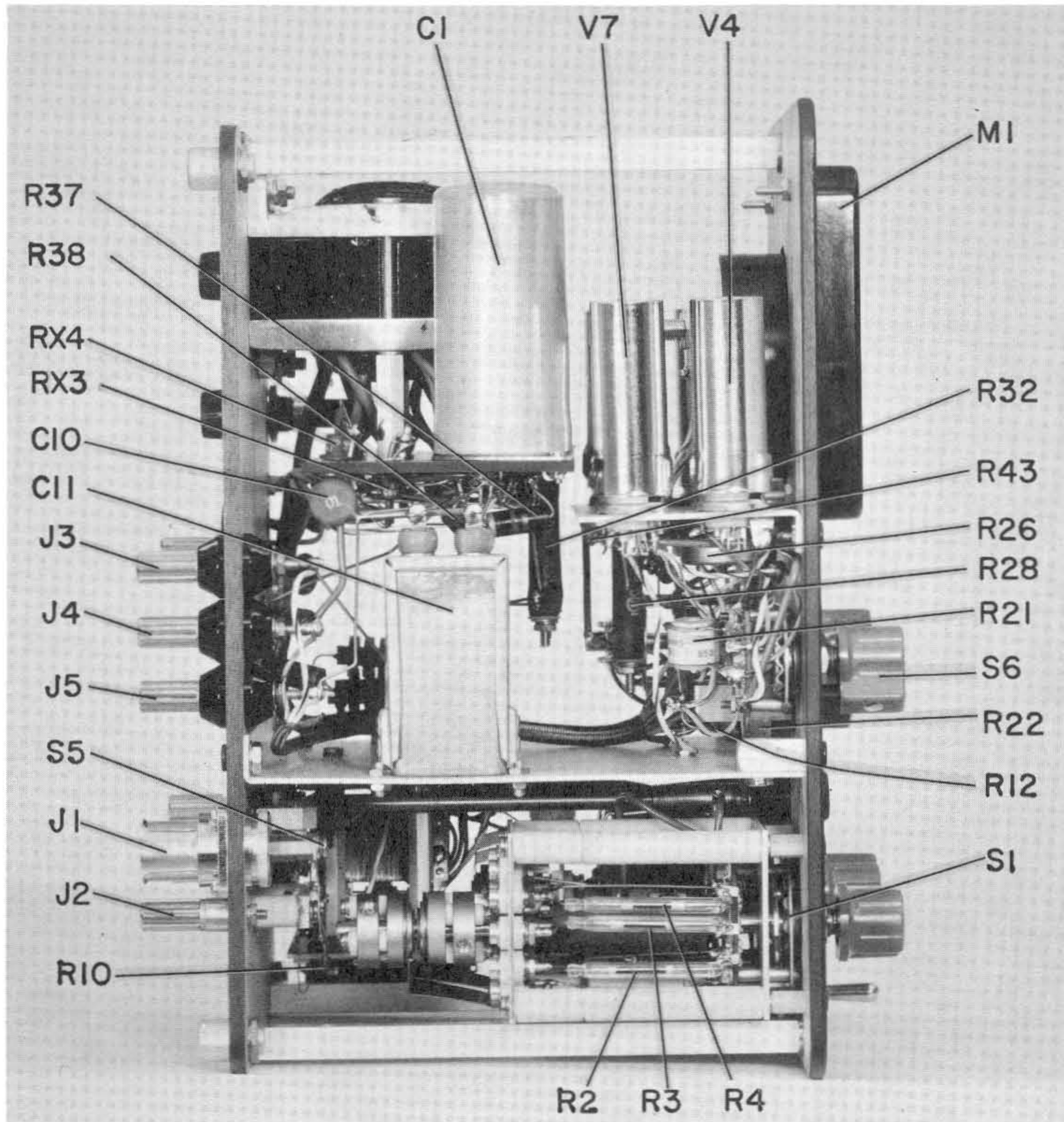
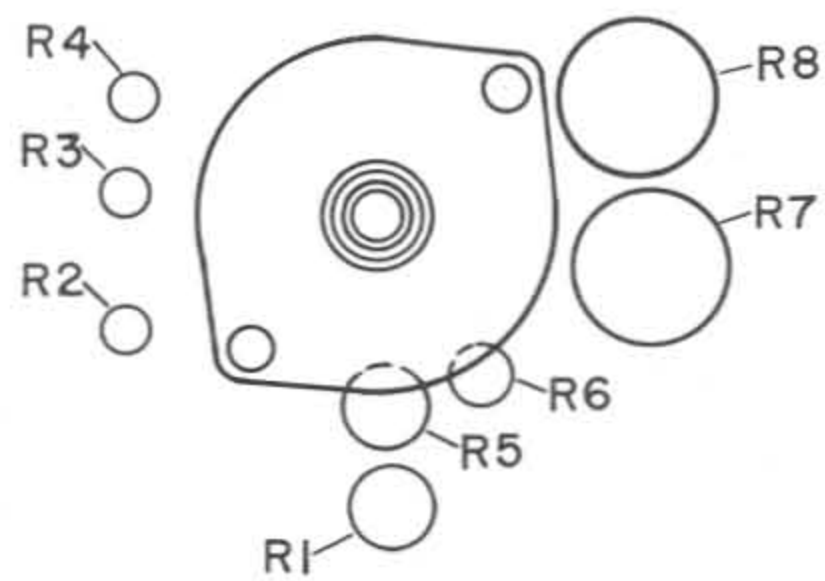

Figure 13. Interior View of Type 1230-A D-C Amplifier and Electrometer.



FRONT VIEW OF SI DETAILS

GENERAL RADIO COMPANY

Section 7
PARTS LIST

		GR NO. (NOTE A)			GR NO. (NOTE A)								
RESISTORS (NOTE B)	R1	101	M	± 1%	2 w	REF-3-3	CAPACITORS (NOTE C)	C1A	25	+100% -10%	450 dcwv	COE-10	
	R2	1030	M	± 5%		Victoreen RX-1		C1B	25				
	R3	10,300	M	± 5%		Victoreen RX-1		C1C	50				
	R4	103,000	M	± 5%		Victoreen RX-1		C4A	25				
	R5	10.1	M	± 1%	2 w	REF-80		C4B	25	+100% -10%	450 dcwv		COE-10
	R6	1	M	± 1%	1 w	REF-75		C4C	50				
	R7	100	k	±0.25%	1/3 w	REPR-16		C6	0.0047				
	R8	10	k	±0.25%	1/3 w	REPR-16		C7	0.0047	±20%	500 dcwv		COC-62
	R9	10	M	± 10%	1/2 w	REC-20BF		C8	0.01	±20%	500 dcwv		COC-62
	R10	10	M	± 10%	1/2 w	REC-20BF		C9	0.01	±20%	500 dcwv		COC-62
	R11A	6		±0.25%	1/2 w	510-419		C10	0.01	±20%	500 dcwv		COC-62
	R11B	14		±0.25%				C11	1.0	±10%	600 dcwv		COL-72
	R11C	40		±0.25%				C12	1.0	±10%	200 dcwv		COW-16
	R12*	15		± 10%		REW-3C	C13	0.01	±20%	500 dcwv	COC-62		
	R13	25	k	± 1%	1/2 w	REF-70	MISCELLANEOUS	F1	FUSE, 0.6-amp Slo-Blo 3AG (for 115-volt input)	FUF-1			
	R14A	140		±0.25%	1/2 w	510-420		F1	FUSE, 0.3-amp Slo-Blo 3AG (for 230-volt input)	FUF-1			
	R14B	400		±0.25%				F2	FUSE, 0.6-amp Slo-Blo 3AG (for 115-volt input)	FUF-1			
	R14C	1400		±0.25%				F2	FUSE, 0.3-amp Slo-Blo 3AG (for 230-volt input)	FUF-1			
	R15	2.2	M	± 10%	2 w	REC-41BF		J1	JACK	1230-202			
	R16	2.2	M	± 10%	2 w	REC-41BF		J2	BINDING POST	BP-10, 11/16			
	R17	180		± 1%		510-390-2		J3	BINDING POST	BP-5			
	R18	1200		± 1%		510-390-2		J4	BINDING POST	BP-5			
	R19	3600		± 1%		510-390-2		J5	BINDING POST	BP-5			
	R20	4700		± 1%		510-390-2		J6	BINDING POST	BP-5			
	R21	15	k	± 1%	1/3 w	REPR-16		J7	BINDING POST	BP-5			
	R22	5	k	± 10%	2 w	POSW-3		L1	INDUCTOR, 2.5 mh	CHA-597			
	R23	5	k	± 10%	2 w	POSW-3	L2	INDUCTOR, 2.5 mh	CHA-597				
	R24	300	k	± 1%	1/2 w	REPR-17	M1	METER, 0-5 ma	MEDS-118				
	R25	200	k	± 5%	1/2 w	REC-20BF	P1	PILOT LIGHT, Mazda No. 44	2LAP-939				
	R26	10	k	± 10%	2 w	POSW-3	PL1	PLUG	ZCPP-10				
	R27	100	k	± 1%	1/2 w	REF-70	RX1	RECTIFIER	IN1695				
	R28	5.6	k	± 5%	10 w	REPO-22	RX2	RECTIFIER	IN1695				
	R29	2.4	k	± 5%	10 w	REPO-22	RX3	RECTIFIER	IN1695				
	R30	100	k	± 10%	1/2 w	REC-20BF	RX4	RECTIFIER	IN1695				
	R31	10	k	± 5%	2 w	REC-41BF	RX5	RECTIFIER	IN1695				
	R32	12	k	± 10%	10 w	REPO-22	RX6	RECTIFIER	IN1695				
	R33	2	k	± 10%	2 w	POSW-3	RX7	RECTIFIER	IN1695				
	R34	15	k	± 10%	1/2 w	REC-20BF	RX8	RECTIFIER	IN1695				
	R35	15	M	± 1%	2 w	REF-80	S1	SWITCH	1230-200				
	R36	2.7	M	± 1%	1 w	REF-75	S2	SWITCH	1230-201				
	R37	300		± 5%	2 w	REC-41BF	S3	SWITCH, dpdt	SWT-335 N.P.				
	R38	300		± 5%	2 w	REC-41BF	S4	SWITCH	SWRW-125				
	R39	3	k	±10%	2 w	REC-41BF	S5	SWITCH, spst	Built-in				
	R40	8.2	k	± 1%	1/2 w	REF-70	S6	SWITCH	SWRW-126				
	R41	10	k	±10%	1/2 w	REC-20BF	T1	TRANSFORMER	485-484				
	R42	330	k	±10%	1/2 w	REC-20BF							
	R43	1.5	k	±10%	1/2 w	REC-20BF							
	R44	10		±10%	1/2 w	REC-20BF							
	R45	2.7		±10%	1/2 w	REW-3C							
R46	3	k	±10%	2 w	REC-41BF	TUBES	**V1	5886	V5	0B2			
R47	47	M	± 5%	1/2 w	REC-20BF		V2	CK6418	V6	0B2			
R48	3	k	± 5%	2 w	REC-41BF		V3	6AN5	V7	0B2			
R49	3	k	± 5%	2 w	REC-41BF		V4	0B2-WA(RCA)	V8	6AL5			

NOTES

- (A) Type designations for resistors and capacitors are as follows:
 COC - Capacitor, ceramic REC - Resistor, composition
 COE - Capacitor, electrolytic REF - Resistor, film
 COL - Capacitor, oil REPO - Resistor, power
 COW - Capacitor, wax REPR - Resistor, precision
 POSW - Potentiometer, wire-wound REW - Resistor, wire-wound
- (B) All resistances are in ohms except as otherwise indicated by k (kilohms) or M (megohms).
 (C) All capacitances are in microfarads.
 * R12 part of P1 socket assembly.
 **Base of V1 tube to be coated with GE Dryfilm SC87 GR Co. No. TUE-3.

INPUT RESISTANCE OR OHMS MULTIPLIER

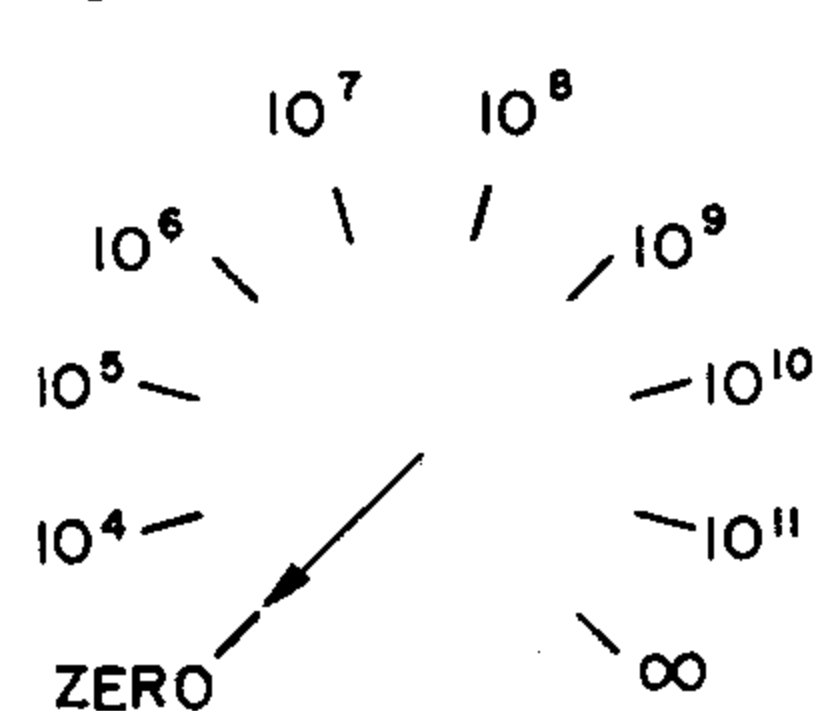

S-1 ENGRAVING

VOLTS

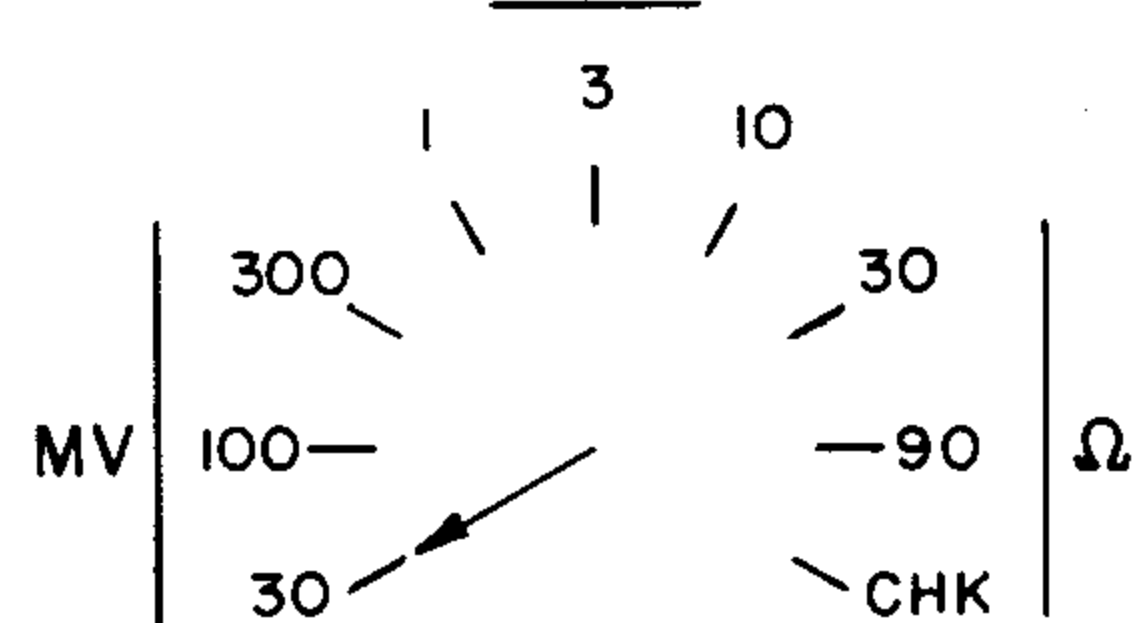

S-2 ENGRAVING

NOTES:

RESISTANCE IN OHMS UNLESS OTHERWISE NOTED
K=1000 OHMS M=1 MEGOHM

CAPACITANCE VALUES IN MICROFARADS UNLESS OTHERWISE NOTED

- SCREW DRIVER ADJUSTMENT
- KNOB CONTROL

NOTE FOR T-1

FOR 115V OPERATION CONNECT

#1 TO #3 & #2 TO #4

FOR 230V OPERATION CONNECT

#2 TO #3

INPUT
115V. OR 230V.
50-60 ~

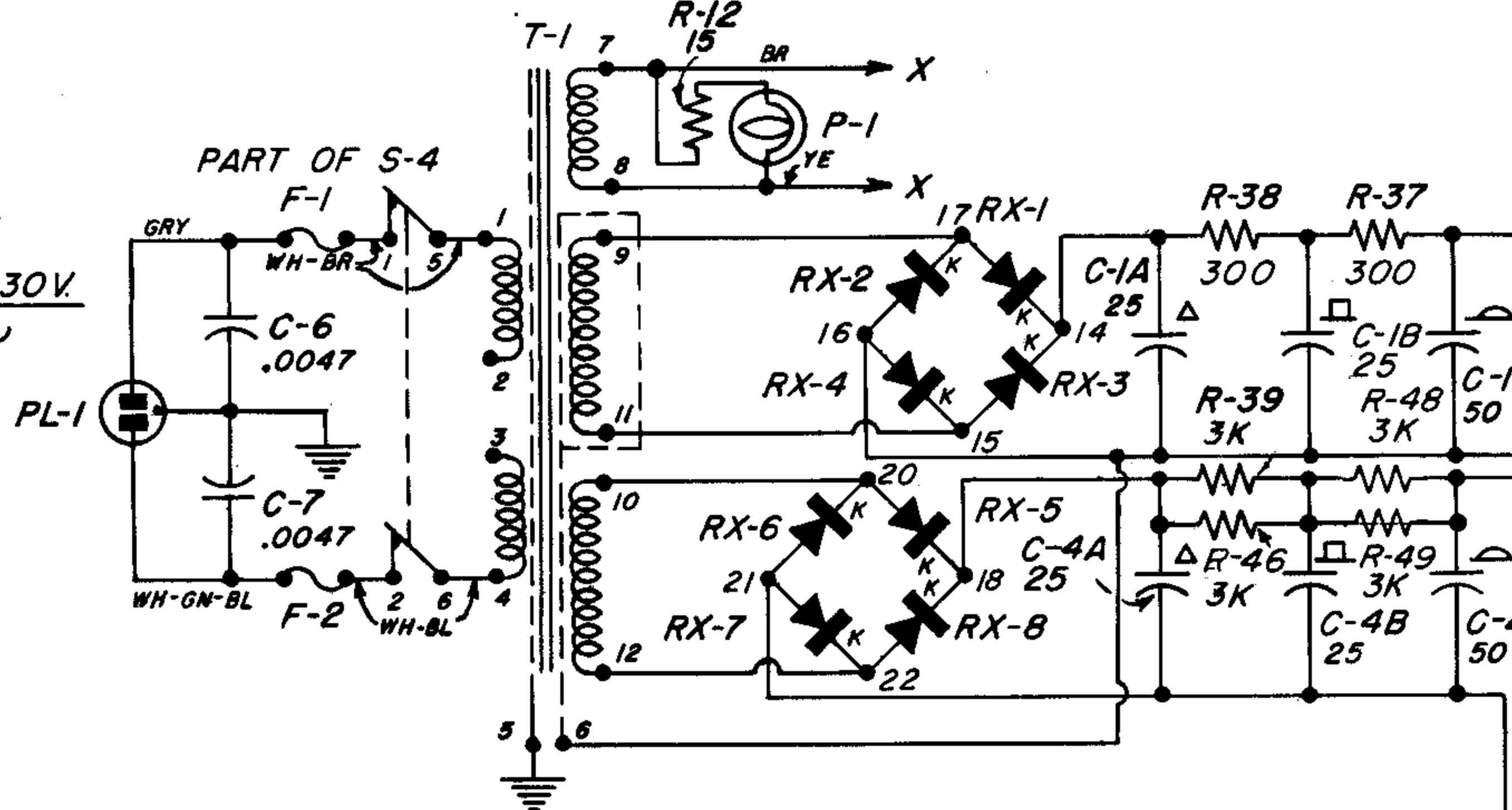

- | | |
|-----|--------------|
| V-3 | 6AN5 |
| V-4 | OB2-WA (RCA) |
| V-5 | OB2 |
| V-6 | OB2 |
| V-7 | OB2 |
| V-8 | 6AL5 |

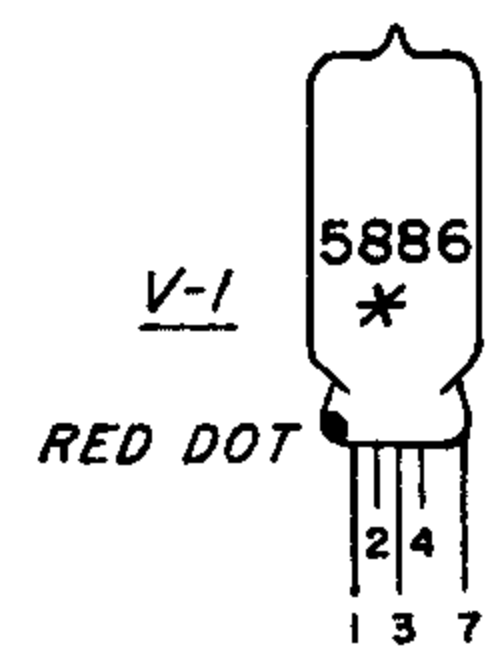
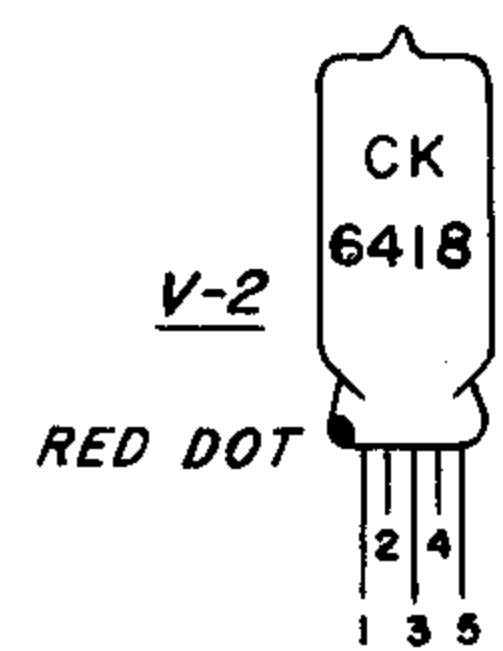

TUBES

*BASE OF V-1 TUBE TO BE COATED WITH GE DRYFILM SC87. G.R. CO. NO. TUE-3

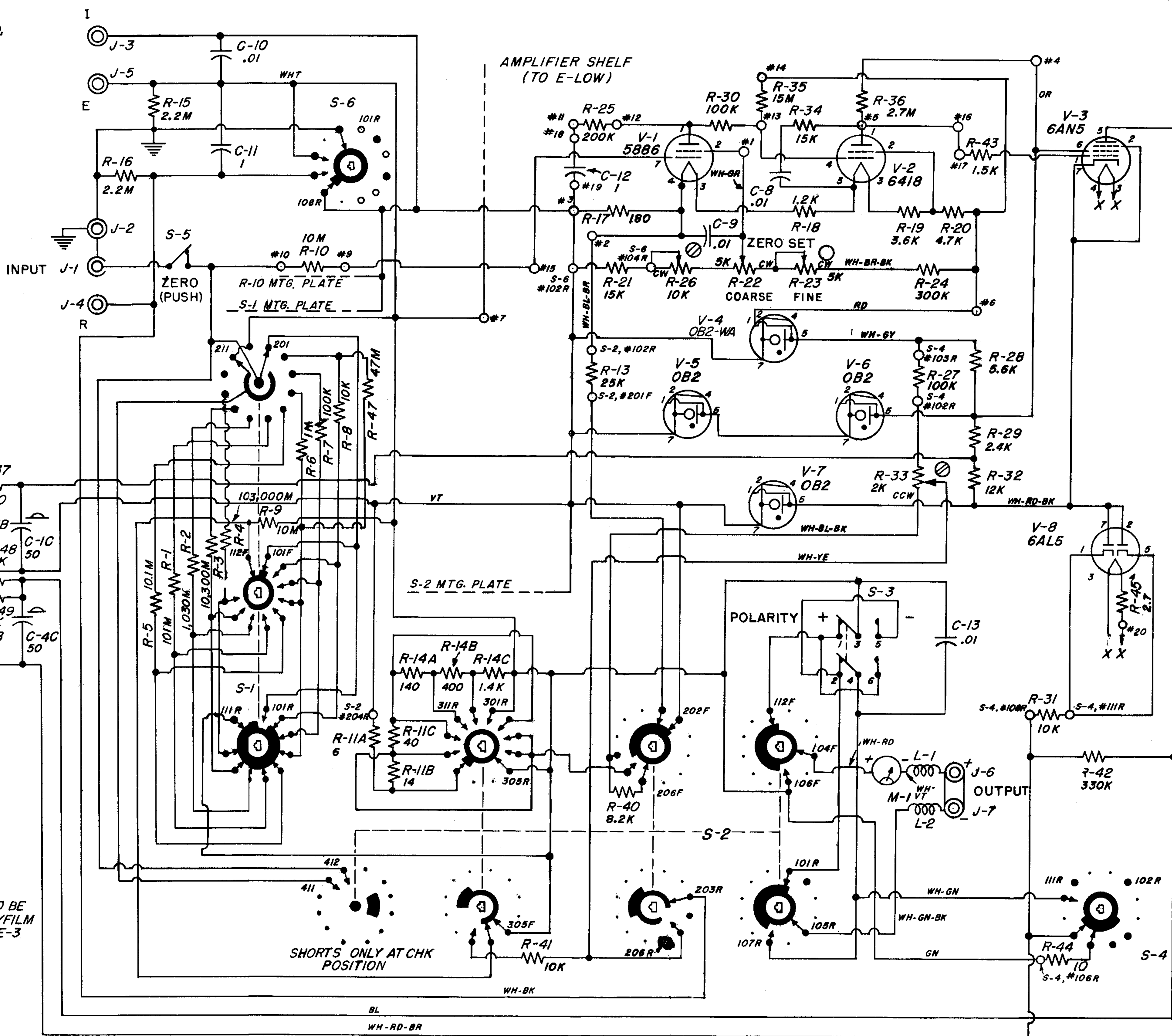
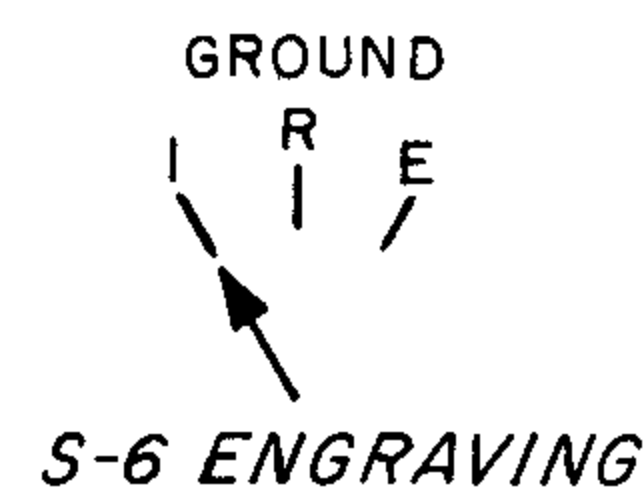
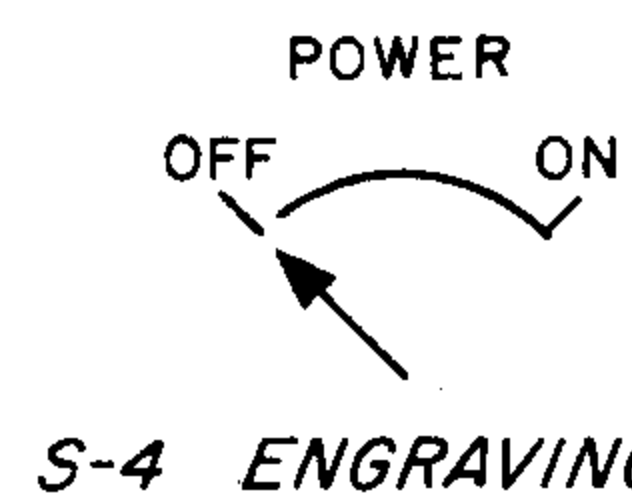

S2 Shown in
30 mv Position

Figure 14. Detailed Schematic Diagram for Type 1230-A D-C Amplifier and Electrometer.

INPUT RESISTANCE OR
OHMS MULTIPLIER

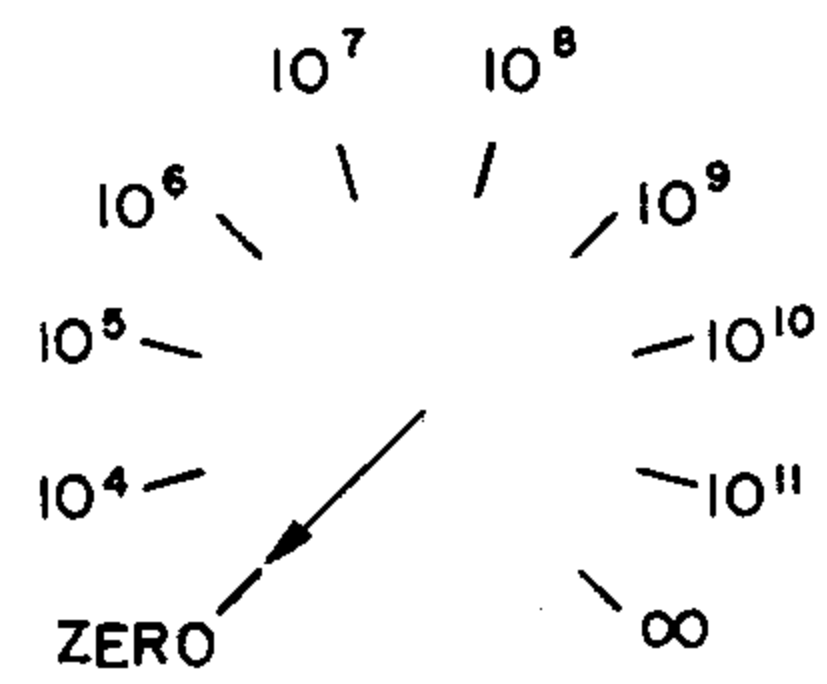

S-1 ENGRAVING

VOLTS

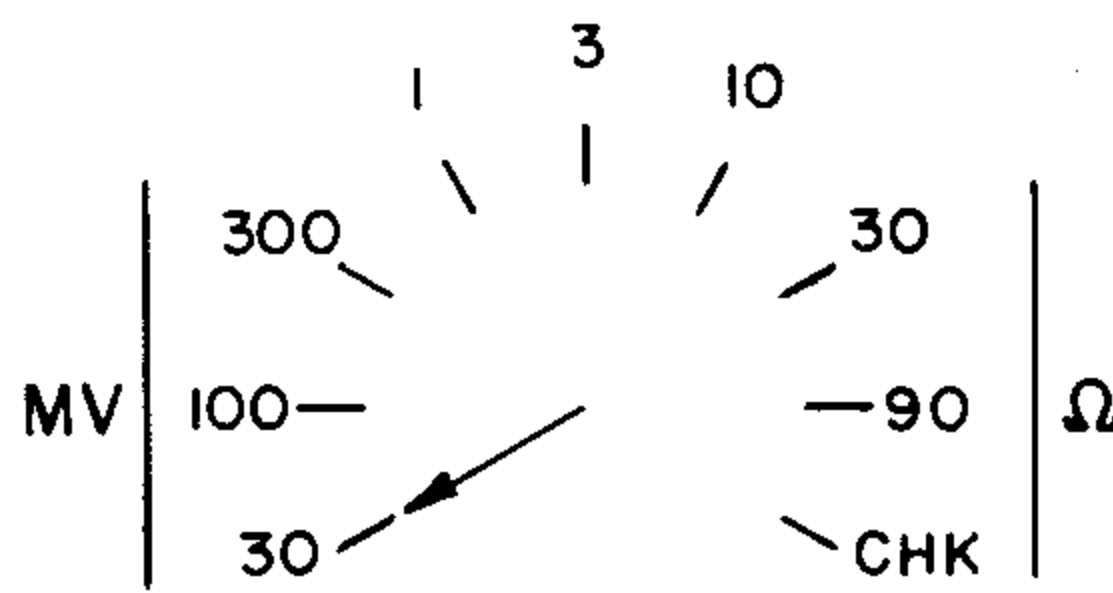

S-2 ENGRAVING



S-4 ENGRAVING

NOTES:

RESISTANCE IN OHMS UNLESS OTHERWISE NOTED
K=1000 OHMS M=1 MEGOHM

CAPACITANCE VALUES IN MICROFARADS UNLESS
OTHERWISE NOTED

- ⊗ SCREW DRIVER ADJUSTMENT
- KNOB CONTROL

NOTE FOR T-1

FOR 115V OPERATION CONNECT
#1 TO #3 & #2 TO #4

FOR 230V OPERATION CONNECT
#2 TO #3

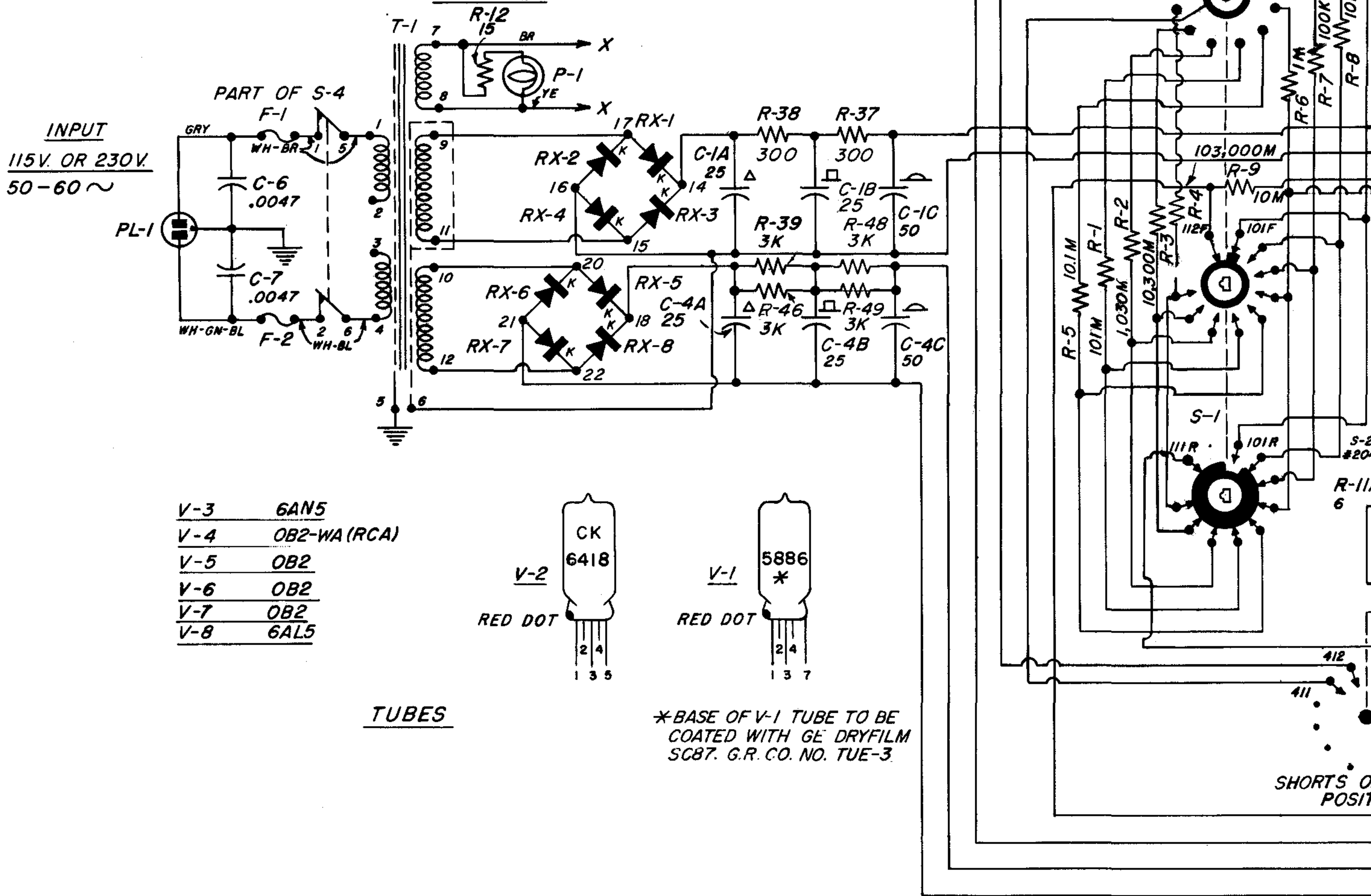

V-3	6AN5
V-4	OB2-WA (RCA)
V-5	OB2
V-6	OB2
V-7	OB2
V-8	6AL5

TUBES

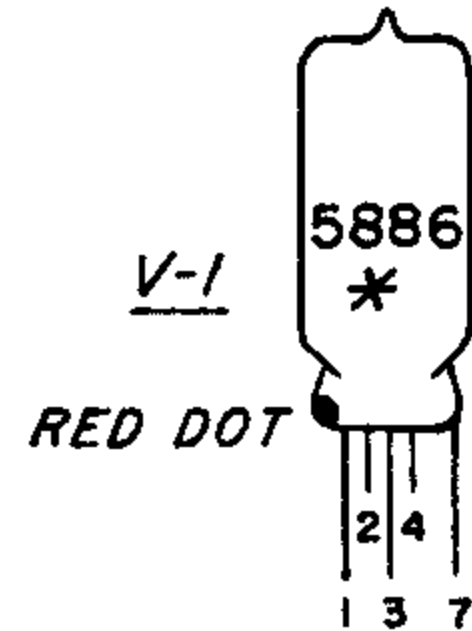
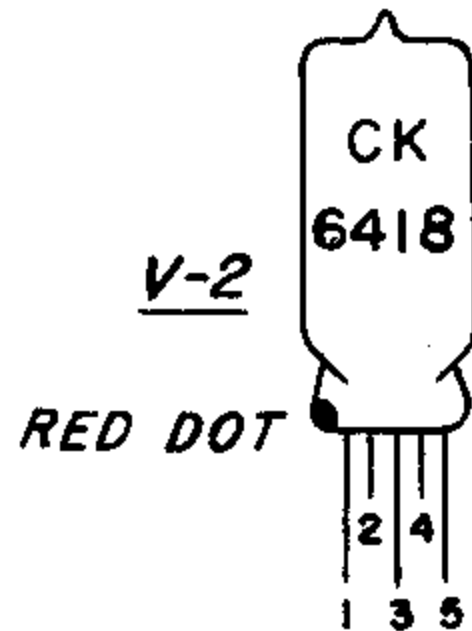

*BASE OF V-1 TUBE TO BE
COATED WITH GE DRYFILM
SC87. G.R. CO. NO. TUE-3.

Figure 14. Detailed Schematic Diagram for Type 1

GROUND
R
E

S-6 ENGRAVING

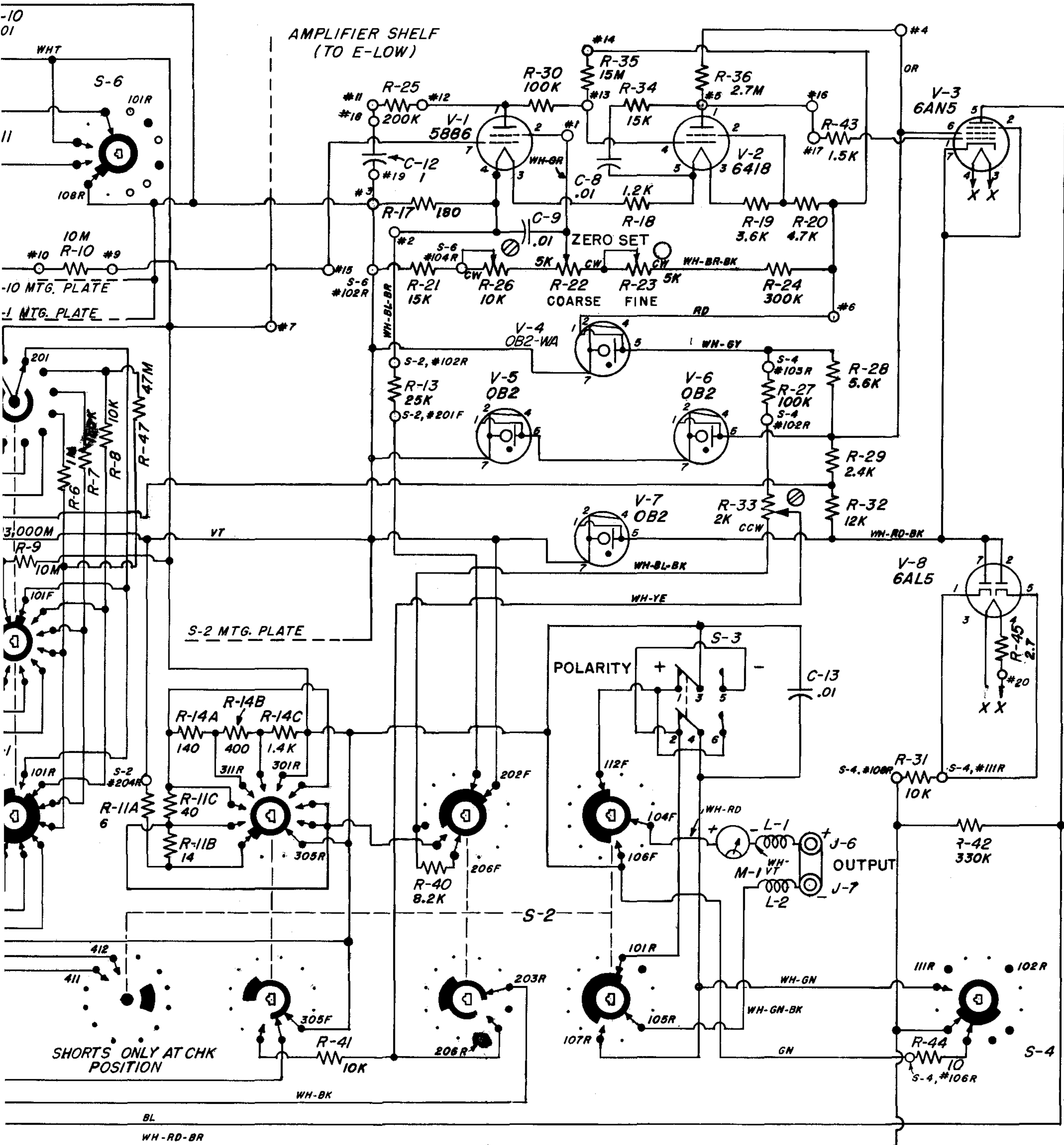

S2 Shown in
30 mv Position

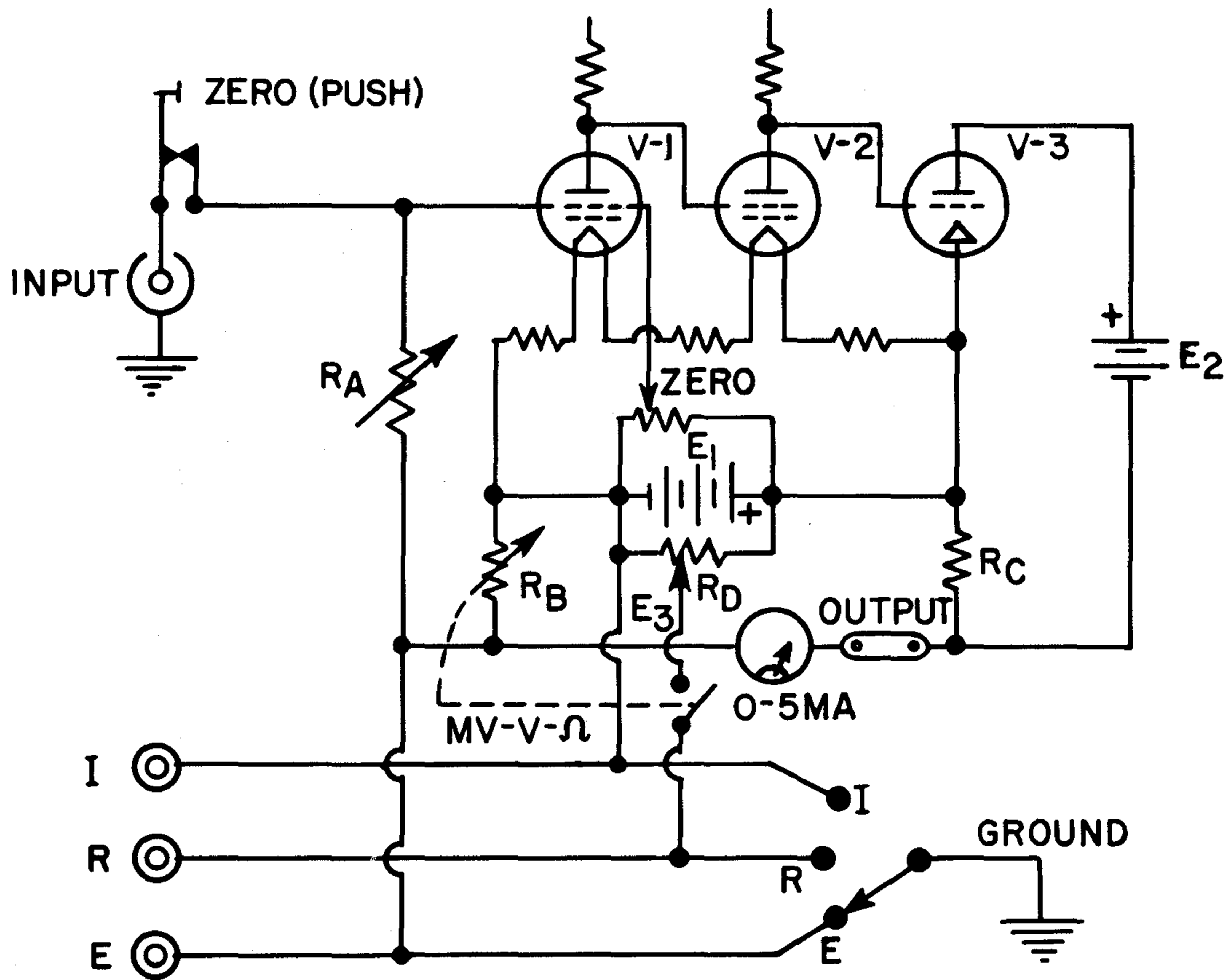

Figure 15. Elementary Schematic Diagram for Type 1230-A D-C Amplifier and Electrometer.

GENERAL RADIO COMPANY

WEST CONCORD, MASSACHUSETTS

EMerson 9-4400

Mission 6-7400

DISTRICT OFFICES

NEW YORK

Broad Ave. at Linden, Ridgefield, N. J.
Telephone N.Y. WOrth 4-2722
N.J. WHitney 3-3140

SYRACUSE

Pickard Bldg.
East Molloy Rd., Syracuse 11, N. Y.
Telephone GLenview 4-9323

PHILADELPHIA

1150 York Rd., Abington, Penna.
Telephone TURner 7-8486
Phila., HANcock 4-7419

WASHINGTON

8055 13th St., Silver Spring, Md.
Telephone JUNiper 5-1088

FLORIDA

113 East Colonial Drive, Orlando, Fla.
Telephone GArden 5-4671

CHICAGO

6605 West North Ave., Oak Park, Ill.
Telephone VIlIage 8-9400

LOS ANGELES

1000 N. Seward St., Los Angeles 38, Calif.
Telephone HOLlywood 9-6201

SAN FRANCISCO

1186 Los Altos Ave., Los Altos, Calif.
Telephone WHitecliff 8-8233

CANADA

99 Floral Pkwy., Toronto 15, Ont.
Telephone CHerry 6-2171

REPAIR SERVICES

EAST COAST

General Radio Company
Service Department
22 Baker Ave., W. Concord, Mass.
Telephone EMerson 9-4400

NEW YORK

General Radio Company
Service Department
Broad Ave. at Linden, Ridgefield, N. J.
Telephone N.Y. WOrth 4-2722
N.J. WHitney 3-3140

MIDWEST

General Radio Company
Service Department
6605 West North Ave., Oak Park, Ill.
Telephone VIlIage 8-9400

WEST COAST

General Radio Company
Service Department
1000 N. Seward St.
Los Angeles 38, Calif.
Telephone HOLlywood 9-6201

CANADA

General Radio Company
Service Department
99 Floral Pkwy., Toronto 15, Ont.
Telephone CHerry 6-2171

General Radio Company (Overseas), Zurich, Switzerland
Representatives in Principal Overseas Countries