

OPERATING INSTRUCTIONS



TYPE **1556-B**

IMPACT-NOISE
ANALYZER

GENERAL RADIO COMPANY

OPERATING INSTRUCTIONS

TYPE 1556-B

**IMPACT-NOISE
ANALYZER**

Form 1556-0110-E
April, 1962

GENERAL RADIO COMPANY
WEST CONCORD, MASSACHUSETTS, USA

TABLE OF CONTENTS

	Page
SPECIFICATIONS	
Section 1. INTRODUCTION	1
1.1 Purpose	1
1.2 Description	1
Section 2. THEORY OF OPERATION	3
2.1 General	3
2.2 Storage System	3
2.3 Reset	3
2.4 Measured Characteristics	3
2.5 Time Duration of Impact	5
2.6 Repeated Measurements	9
2.7 Use with Spectrum Analyzer	9
2.8 Selection of Microphone	12
2.9 Use with Vibration Meter	13
2.10 Other Uses	13
Section 3. INSTALLATION	14
3.1 Signal Connection	14
3.2 Fastening to Type 1551 Sound-Level Meter	14
Section 4. OPERATING PROCEDURE	15
4.1 Start-Up	15
4.2 Calibration	16
4.3 Measurement of Impact Noise	17
4.4 Pushbutton Reset	21
4.5 Time Duration of Impact	22
4.6 Peak Sound Pressure	22
Section 5. SERVICE AND MAINTENANCE	23
5.1 General	23
5.2 Batteries	23
5.3 Trouble-Shooting	24
5.4 Transistor Checks	26
Section 6. PARTS LIST	28

SPECIFICATIONS

Input Level: Between 1 and 10 volts for normal range. Levels below 1 volt reduce the range of reading.

Input Impedance: Between 25,000 and 100,000 ohms, depending on LEVEL control setting.

Frequency Range: 5 cps to 20 kc.

Level Indication: Meter calibrated in decibels from -10 to +10. Added attenuator switch increases range by 10 db.

Peak Reading: Rise time is less than 50 μ sec for a value within 1 db of peak (for rectangular pulses). Storage time at normal room temperature is more than 10 sec for a 1-db change in meter reading.

Quasi-Peak Reading: Rise time is less than 1/4 msec, and decay time is 600 ± 120 msec for rectifier circuit.

Time-Average Reading: Charge time of rectifier circuit selected by seven-position switch, with times of 0.002, 0.005, 0.01, 0.02, 0.05, 0.1, and 0.2 sec for the r-c time constant. Storage time at normal room temperature is more than 1 min for a 1-db change in meter reading.

Accessories Required: A sound-level meter or spectrum analyzer should normally be used to supply the analyzer input.

Input Terminals: An attached cord with phone plug.

Batteries: One 1½-volt size D flashlight cell (Rayovac 2LP or equivalent) and one 45-volt B battery (Burgess XX30 or equivalent) are supplied.

Tubes: One Type CK6418:

Two Type 2N1372 and one Type 2N1374 transistors or equivalent.

SPECIFICATIONS (Cont)

Cabinet: Aluminum, finished in gray. Carrying case supplied.

Mounting: May be fastened to end frame of the Type 1551 Sound-Level Meter.

Dimensions: Width $7\frac{1}{2}$, height $6\frac{1}{2}$, depth $4\frac{1}{4}$ inches (195 by 165 by 110 mm), over-all.

Net Weight: Instrument, $4\frac{1}{2}$ lb (2.1 kg); carrying case, 1 lb (0.5 kg).



Figure 1. Panel View,
Type 1556-B Impact-Noise Analyzer.

TYPE 1556-B

IMPACT-NOISE ANALYZER

Section 1 INTRODUCTION

1.1 PURPOSE. The Type 1556-B Impact-Noise Analyzer (Figure 1) is an amplifier-voltmeter system designed to measure peak value, maximum instantaneous level, and time duration of impact sound or vibration. By means of an electrical storage system in the instrument, all three characteristics of a single impact can be measured with only one indicating meter. The Impact-Noise Analyzer is usually used to measure the output of a Type 1551 Sound-Level Meter, a Type 1550-A Octave-Band Noise Analyzer, a Type 1553-A or 761-A Vibration Meter, or a magnetic tape recorder.

1.2 DESCRIPTION.

1.2.1 CONTROLS. The chart on page 2 lists the controls on the panel of the Type 1556-B Impact-Noise Analyzer.

1.2.2 CONNECTIONS. An attached cable, terminated in a telephone plug, is used to connect the Impact-Noise Analyzer to the instrument supplying the signal.

Name	Description	Positions	Function
DECIBELS	100- μ a meter		Indicates level.
-10 db	Spring-return toggle switch (S4)	normal, -10 db	Increases sensitivity of metering circuit by 10 db when in -10 db position.
RESET	Continuous rotary control		Sets initial deflection of indicating instrument to reference mark.
LEVEL	Continuous rotary control		Sets over-all sensitivity of metering circuits.
TIME CONSTANT	7-position rotary selector switch (S2)	.002, .005, .01, .02, .05, 0.1, 0.2	Selects time constant of rc circuit used in TIME AVG rectifier circuit.
	5-position rotary selector switch (S1)	OFF, POS, NEG, FIL, PL	Energizes instrument; selects half (positive or negative) of wave to be measured; checks batteries.
	4-position rotary selector switch (S3)	RESET, TIME AVG, PEAK, QUASI PEAK	At RESET, discharges storage capacitors; determines which characteristic of wave is to be indicated.
	pushbutton		When pushed, discharges storage capacitors.

Section 2 THEORY OF OPERATION

2.1 GENERAL. As illustrated in the simplified schematic diagram (Figure 6 on foldout), the amplifier of the Impact-Noise Analyzer drives three dc voltmeter circuits simultaneously. These consist of rectifiers, storage capacitors, and a common electronic dc voltmeter.

2.2 STORAGE SYSTEM. The electrical storage system, which is a capacitor charged by a rectifier, makes it possible to measure three characteristics of a single impact with only one indicating meter. So that the charge will remain stored in the capacitor for some time, the electrical leakage of the rectifier must be extremely low in the reverse direction. It is for this purpose that the instrument employs silicon-junction diode rectifiers.

2.3 RESET. After the measurement of a single impact, the capacitors in the metering circuit are discharged when the four-position selector switch (S3) is set to RESET or the pushbutton is depressed. The instrument is then ready to measure another impact, and all three rectifier circuits are in operation if S3 is out of the RESET position and the pushbutton is released.

2.4 MEASURED CHARACTERISTICS.

2.4.1 GENERAL. The three characteristics that can be measured by means of the Impact-Noise Analyzer are labeled on the instrument as QUASI PEAK, PEAK, and TIME AVG (time average).

2.4.2 QUASI PEAK. The QUASI PEAK is a continuous indication of the higher sound-pressure levels occurring just before the time of indication. The electrical circuit of the QUASI PEAK system has a fast rise time (a fraction of a thousandth of a second) and a slow decay time (about six tenths of a second), so that the fast indicating meter on the instrument can follow reasonably well the peak levels of sound. This measure of the sound is useful for repeated impacts, serves as a convenient indicator for calibration of the system, and has the characteristics proposed as standard for the measurement of electrical impulse noise.¹

2.4.3 PEAK. The PEAK is the maximum sound-pressure level reached by the noise after the analyzer control (four-position selector switch S3) is switched out of the RESET position, or, if S3 is out of the RESET position, after the push-button is released. The time required for the instrument to note the peak level is so short (about one ten-thousandth of a second) that for sound waves it can be regarded as instantaneous. This PEAK level is stored electrically for a number of seconds so that the level can be read on the indicating instrument at leisure.

Comparisons made between the peak levels of impact sounds measured on this instrument and

¹American Standards Association, C63.2-1950, "Proposed American Standard Specifications for a Radio Noise Meter, 0.015 to 2.5 Megacycles/Second."

those measured by the cathode-ray oscilloscope technique show agreement generally within one decibel.

2.4.4 TIME AVG. The time-average level is obtained by a capacitor charged through a rectifier and a series resistor. One of seven different series resistors can be selected by the time constant switch to provide different charging times ranging from two milliseconds to 0.2 second. The time-average level is a measure of the level maintained over a period of time. The actual averaging time is set by the charging time and the shape of the pressure wave. The time-average level is also stored in an electrical capacitor so that it can be read on the indicating instrument at leisure.

2.5 TIME DURATION OF IMPACT.

2.5.1 GENERAL. The difference between the peak level and the average level is used to determine the time duration of the wave. The method of specifying a particular time duration for complicated impact waves is not obvious. If they were simple rectangular pulses, there would be no problem. Such a condition will be used to illustrate the basis of the procedure adopted for the more complicated waves.

2.5.2 RECTANGULAR PULSES. Assume we set the charging time of a rectifier circuit to be 0.01 second. If we suddenly apply a constant voltage across this rectifier circuit, current

flowing into the capacitor will result in an increase in voltage across it. The longer this voltage is applied, the closer will the voltage across the capacitor approach the applied voltage. If it lasts for 0.002 second, the capacitor voltage should be 15 decibels less than the applied voltage. If it lasts for 0.01 second, however, the capacitor voltage should be only 4 decibels less than the applied voltage. This relation is plotted in Figure 2. Some experimental results obtained with the Impact-Noise Analyzer used to measure known rectangular pulses are shown in Figure 2. The ratio of applied voltage to voltage across the capacitor is plotted in decibels along the horizontal axis, and the ratio of the duration of the applied voltage to the charging time of the rectifier circuit is plotted along the vertical axis. The close agreement of the measured values to the theoretical relation indicates that the circuits are operating as expected.

If we applied a rectangular pulse of unknown duration to this instrument, we could use the results of measurements to determine the duration. The PEAK circuit charges very quickly to the full applied voltage, so it is used as a reference. The ratio, in decibels, of the peak value to the averaged value is used with the chart to determine the duration of the pulse. For example, assume that the indicated peak level is 138 db, and that the level with an averaging time of 0.002 second is 130 db. The difference in level

is 8 decibels. From Figure 2 we see that this difference corresponds to a time ratio of 0.5. The pulse duration, therefore, was one half of 0.002 second, or 1 millisecond.

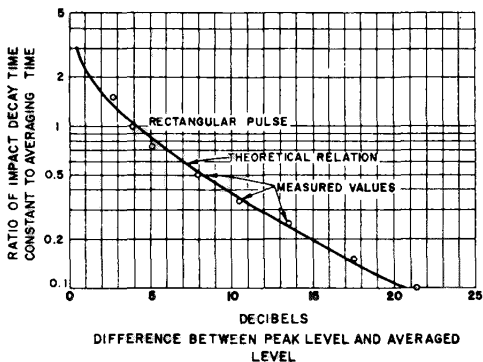

Figure 2. Relations Between Ratio of Peak to Averaged Value and Time Constants of Impact and Circuit (for rectangular pulses).

2.5.3 IMPACT NOISE. Impact noises, however, are not as simple as rectangular pulses. Rather they appear to be, to a first approximation, exponentially decaying random noises. If we take such an applied wave, we can compute a relation similar to that given for rectangular pulses. This relation, as shown in Figure 3, is based on the assumption that the charging time of the peak circuit is about a thousandth the decay

time of the exponentially decaying wave. This assumption appears to be justified for most impact noises encountered in industry. Also, we define the decay time constant in the same way as in electrical circuits. The time constant is the time required for the wave to drop 8.7 decibels in level from its initial value.

The following example shows how this relation can be used. Measurements of a small

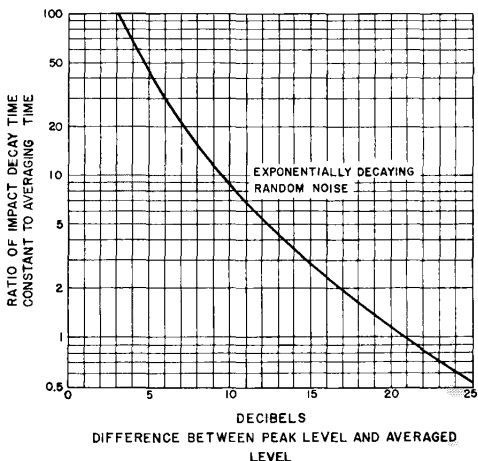

Figure 3. Relations between Ratio of Peak to Averaged Value and Time Constants of Impact and Circuit (for impact noises).

punch press stamping out blanks gave a peak level of 115 db and a time-averaged level of 98, with a time constant of 0.01 second. The difference in level is 17 decibels, which, in Figure 3, corresponds to a time ratio of 2. The equivalent impact decay time is then 2 times 0.01 second, or 20 milliseconds.

No procedure for the determination of impact-noise decay time has been standardized, and the relation shown in Figure 3 may have to be modified as more experience is gained in these measurements. The original data should, therefore, be preserved, so that revised values can be calculated in the light of a revised relation.

2.6 REPEATED MEASUREMENTS. Because most impact noises do not repeat identically in level and duration, a number of samples of such sounds should be measured in order to determine the variability and to obtain a representative value for the sound. It is suggested that the median, or middle value, be used to determine this representative value. In stating the results of a series of such measurements, it is helpful to give the extreme values, or at least some statistical measure of the distribution of values.

2.7 USE WITH SPECTRUM ANALYZER.

2.7.1 GENERAL. The Impact-Noise Analyzer can be used to measure the output of a spectrum analyzer, such as the Type 1550-A Octave-Band Noise Analyzer. The Octave-Band Noise Analy-

zer may be driven by a sound-level meter, a magnetic tape recorder, or, if the noise level is high enough, by a microphone. The measured values for each octave band are used to compute a peak value and a decay time, just as in the direct measurement. It is not clear that the measured peak level in any band is significant in itself, since this peak is not actually present in the sound wave. We can, however, use the peak level and the time-averaged level to determine an equivalent decay time for the noise in each band. It will be found, in general, that lower-frequency components decay less rapidly than do higher-frequency components. (See Figure 4.)

2.7.2 FILTERING-EQUIPMENT LIMITATIONS.

2.7.2.1 Effect of Filter Response Time. An electrical filter network does not respond instantaneously to a signal suddenly applied at its input. With a narrow-band filter, the rise time or response time of the output will be relatively long. Similarly, if a signal suddenly drops in intensity, the decay time of the output of a narrow-band filter will be relatively long. For an octave-band filter the time will be different for each different band. If a single tuned circuit is used to do the filtering, the response times will be as shown in the lower curve of Figure 4. However, such a filter is not selective enough for noise analysis, and more complicated networks are used in order to obtain

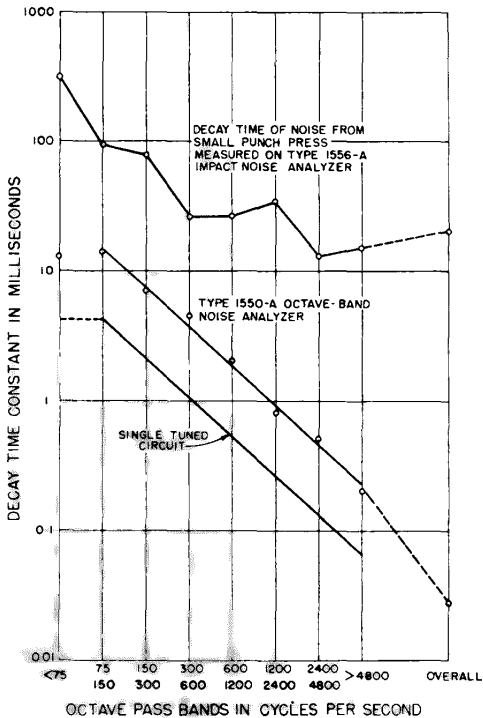

Figure 4. Filter Response Times.

greater selectivity. As a by-product, the response time of the filter is increased, as shown in the middle curve of Figure 4, which applies to the Type 1550-A Octave-Band Noise Analyzer. Here the response time ranges from 14 milliseconds for the narrowest band down to 0.2 millisecond for the upper band. Fortunately, these response times are appreciably faster than the decay times of the filtered noise from most impact noise sources. If the measured decay time of the noise is three or more times the filter response time shown in Figure 4, the effect of the filter response time can usually be neglected.

2.7.2.2. Effect on Measured Peak Level. The effect of filtering on the measured peak level is more difficult to assess for impact noises, but can be considered in the light of overshoot. Overshoot, a common measure of the transient behavior of a filter, is the maximum extent by which the output of a filter exceeds the steady-state output when a signal in the pass band is suddenly applied to the input. In the octave-band analyzers commonly used, this overshoot is about one or two decibels. Exactly how such a measure is to be applied to impact noises is not clear. At most, it probably indicates something about the possible uniformity obtainable for the peak level when different octave-band analyzers are used on the same signal.

2.8 SELECTION OF MICROPHONE. For noise studies in general, it is desirable to use a micro-

phone of wide frequency range, such as the Type 1551-P1L or 1551-P1H Condenser Microphone System. As a matter of actual practice, however, the ordinary measurement microphones furnished with sound-level meters are satisfactory for many impact noise signals. When oscillograms of successive impacts are taken using the same microphone, the oscillograms differ in detail. The result is similar to that of a sampling of random noise, in that no two samples are identical. The variation from one sample to the next with two different types of microphones does not seem to be appreciably greater than the variation from one sample to the next with the same microphone, provided that both microphones are at least as good as those normally supplied with sound-level meters. Thus, for preliminary work and general surveys, the type of microphone usually furnished with the sound-level meter is adequate. If a careful research study is to be made, however, it is recommended that a microphone having uniform response over a wide frequency range be used.

2.9 USE WITH VIBRATION METER. The output of a Type 1553-A or Type 761-A Vibration Meter can be fed to the Impact-Noise Analyzer, which will measure the peak value of vibration. The general procedure is the same as that for use with the Type 1551 Sound-Level Meter.

2.10 OTHER USES. The Impact-Noise Analyzer may be useful in approximate measurement

of loudness of certain types of noise, and in studies of sputtering, clicking, buzzing, and other sounds. Since these applications have not yet been fully investigated, operating procedures cannot be set forth.

Section 3 INSTALLATION

3.1 SIGNAL CONNECTION. Using the cord and plug assembly provided, connect the Type 1556-B Impact-Noise Analyzer to the output of the instrument supplying the signal. For example, if the analyzer is to be connected to the Type 1551 Sound-Level Meter, plug into the OUT jack on the Sound-Level Meter. If the analyzer is to be connected to the Type 1550-A Octave-Band Noise Analyzer, plug into the AMPLIFIER OUTPUT jack on the Octave-Band Noise Analyzer.

The instrument supplying the signal should be capable of providing one volt rms across 25,000 ohms.

3.2 FASTENING TO TYPE 1551 SOUND-LEVEL METER. The Impact-Noise Analyzer can be mounted on the Type 1551 Sound-Level Meter. The procedure is as follows:

- a. Remove the two binder-head screws from their inserts in the end of the Sound-Level Meter.
- b. Remove the cover of the Impact-Noise Analyzer by loosening the panel screw on the side of the instrument and sliding the cover downward.

c. Remove the flashlight battery and its spring-clip holder by pulling it straight out. (The end tabs of the spring clip can be gripped as a handle.)

d. Remove the binder-head screw from the rubber grommet in one corner of the amplifier shelf. Remove the similar binder-head screw from the back cover of the Impact-Noise Analyzer.

e. When the analyzer is placed against the end of the Sound-Level Meter, two large holes in the back cover of the analyzer line up with the inserts on the Sound-Level Meter. Insert the two screws removed in step d from the inside of the analyzer through these two holes to secure the analyzer to the Sound-Level Meter.

f. Replace the flashlight battery and cover, and tighten the panel screw.

Section 4 OPERATING PROCEDURE

NOTE

When instrument is not in use, switch S3 should always be in RESET position and S1 in OFF position.

4.1 START-UP.

a. Turn the instrument on and check the batteries by setting the five-position selector switch S1 to FIL (filament battery) and then PL (plate battery), checking that the indicating meter reads beyond the red line (B) on the scale.

b. Set S1 to POS (positive) and the four-position switch S3 to RESET. Depress the toggle

switch to the -10 db position. Note that the indicator is now on the first mark on the left side of the meter. If the meter is not at this point, wait a few minutes, then set the pointer to the mark by means of the RESET thumb adjustment.

4.2 CALIBRATION.

4.2.1 WITH SOUND-LEVEL METER.

a. Set S3 to QUASI PEAK. Apply a sine-wave signal to the sound-level meter (preferably by its internal calibration system), and set the LEVEL control so that the indicating meter reads 2-1/2 db higher than the reading on the sound-level meter. Because of the, required ratio of charge and discharge times for this QUASI PEAK measurement, the actual sine-wave output is about 1/2 db less than that produced by a true peak meter, which reads 3 db higher than r-m-s for a sine wave; therefore, setting the indicating meter 2-1/2 db higher than the Sound-Level Meter will cause the analyzer to read peak values.

b. Set S3 to RESET and then switch in turn to TIME AVG and PEAK to see that the meter reading is approximately 3 db higher than that of the Sound-Level Meter.

c. Again set the switch to RESET and switch out of the calibration position of the Sound-Level Meter. The instrument is now calibrated to read peak values.

d. Since the analyzer is highly stabilized by the use of negative feedback, it is not usually

necessary to make any appreciable readjustment of the calibration until the batteries run down, provided the gain of the sound-level meter output system remains stable. It is, of course, desirable to check the calibration before making measurements to see that everything is working properly.

4.2.2 WITH OCTAVE-BAND ANALYZER.

a. Apply a sine-wave signal to the octave-band analyzer with the BAND, CYCLES switch set at 20c-10kc. This signal would usually be obtained from the Sound-Level Meter (refer to paragraph 4.2.1) to which the Octave-Band Analyzer is connected.

b. Adjust the LEVEL control of the Octave-Band Analyzer, as specified in the operating instructions for that instrument, so that the indicating meter reads the same as that of the Sound-Level Meter.

c. Set S3 to QUASI PEAK.

d. Set the LEVEL control of the Impact-Noise Analyzer so that its indicating meter reads 2-1/2 db higher than the reading on the Sound-Level Meter.

e. Proceed as outlined in paragraphs 4.2.1b and 4.2.1c.

4.3 MEASUREMENT OF IMPACT NOISE.

4.3.1 GENERAL.

a. With the Impact-Noise Analyzer connected to the Sound-Level Meter, set up the microphone and the Sound-Level Meter to supply the input.

b. Set the attenuator of the Sound-Level Meter 10 to 20 db higher than under ordinary circumstances, since the peaks of impact sounds are from 15 to 30 db higher than the value indicated on the standard Sound-Level Meter.

c. Set the TIME CONSTANT switch to the desired value. For most impact noises, a setting of 0.01 is recommended.

d. Set S3 to RESET. This restores the electrical circuits to the initial state, erasing any stored voltages that may have remained from a previous measurement.

e. Set S1 to POS or NEG, depending on which half of the pressure wave is to be measured. When the instrument is used with the Type 1551 Sound-Level Meter with its Rochelle Salt microphone, the POS position ordinarily corresponds to excess pressure. The POS position is recommended for most applications.

4.3.2 MEASUREMENT OF SINGLE IMPACT NOISE.

a. Just before the impact occurs, set S3 to QUASI PEAK.

b. When the impact occurs, note the peak excursion of the meter. Switch to the PEAK setting, and observe the meter reading corresponding to the voltage that has been stored electrically. If the reading is at 10 or beyond full scale, set the attenuator of the Sound-Level Meter 10 db higher and repeat the measurement, starting with the switch first at RESET. When the peak

reading appears between 0 and 10 db, the most accurate measurement of the peak value is obtained.

c. The peak level is then given as the sum of the readings of the Sound-Level-Meter attenuator and of the indicating meter on the Impact-Noise Analyzer. (Note that the reading of the indicating meter of the Sound-Level Meter is not included.)

d. Switch to the TIME AVG position and record the reading. The time-average level is the sum of the readings of the Sound-Level-Meter attenuator and of the analyzer indicating meter. If the analyzer meter reading is less than 0 db, depress the toggle switch to the -10 db position and again read the meter. The level indicated with the switch depressed is reduced by 10 db.

e. If the measurement, with a TIME CONSTANT of 0.01, gives a difference between the PEAK and TIME AVG levels of less than 5 db, change the TIME CONSTANT to a larger value and repeat the measurement. If the difference is more than 15 db, change to a TIME CONSTANT of 0.005 or 0.002 and repeat the measurement. For each measurement be sure to record the TIME CONSTANT used.

4.3.3 MEASUREMENT OF MULTIPLE IMPACT NOISES.

4.3.3.1 General. Measurements are readily made on machines that produce many impacts in succession, but the procedure must be modified somewhat.

4.3.3.2 Quasi Peak. After calibration, switch from RESET to QUASI PEAK and record the maximum and minimum excursions of the indicating meter.

NOTE: When low-level noises are measured, switch carefully so as to avoid excessive acoustic noise from the switch.

4.3.3.3 Peak. Switch from RESET to PEAK and note the reading of the indicating meter. This reading is the highest peak level occurring during the period from the time it is switched from RESET to the time the reading was taken. If it is desired to see how uniformly the peak levels are reproduced for different impacts, switch back and forth from RESET to PEAK and note each reading, until the desired number of samples have been obtained.

4.3.3.4 Time Average. Switch from RESET to TIME AVG and note the reading. On each successive impact the reading will increase. If the impacts are separated by intervals of a second or more, it is usually possible to take a reading on the first impact after the switch is set to TIME AVG. Again, a series of samples can be taken.

If the impacts are too frequent to permit use of the above procedure, the number of impacts required for the TIME AVG level to reach a certain value can be determined either by the number of impacts or by the time of rise of the TIME AVG level. It is recommended that the terminating level selected be 10 db below the PEAK

level. (Note that S3 can be switched back and forth between PEAK and TIME AVG without interfering with the buildup of the TIME AVG level. If the switch is set to RESET, however, the stored level is erased.) For this type of measurement it is usually desirable to set the TIME CONSTANT switch to a value greater than 0.01. A value of 0.05 is generally recommended. Always record the value used.

4.3.3.5 Repetition Rate. The repetition rate of the impact noise should usually be recorded on the data sheet, along with the data obtained from the Impact Noise Analyzer, since this rate may be a factor in estimating the effects of the noise. This repetition rate is not measured by the Impact Noise Analyzer, but it can usually be determined by means of a simple timing device or procedure.

4.4 PUSHBUTTON RESET. When the pushbutton on the front panel is depressed, the storage capacitors for both PEAK and TIME AVG are discharged. Then, when the button is released, the instrument is ready to measure another impact if the switch S3 is also out of the RESET position. For many applications, therefore, it may be more convenient to set S3 to PEAK or TIME AVG, as desired, and to do all resetting with the pushbutton. This procedure is particularly useful when a series of peak measurements are to be made or when it is necessary to avoid

the acoustic noise that accompanies the operation of S3.

A center hole in the RESET pushbutton is threaded to take a standard small cable release, for convenient hand operation.

4.5 TIME DURATION OF IMPACT. The difference between the peak level and the average level is used to obtain a measure of the time duration of the wave. (Refer to paragraph 2.5.)

4.6 PEAK SOUND PRESSURE. The peak sound-pressure level is obtained with respect to a reference pressure of 0.0002 microbar. To determine the peak sound pressure, subtract 74 db from the observed peak sound-pressure level, and translate the resultant value into the corresponding numerical value of pressure by means of decibel tables. (Decibel tables are given in the General Radio Handbook of Noise Measurement and in the General Radio Catalog.) For example, assume that the measured peak value is 122 db (re 0.0002 microbar). Then $122 - 74 = 48$ db (re 1 microbar), which, from the decibel table, is 250 microbars.

The following values may be useful as references:

Standard atmospheric pressure = 1,013,250 microbars.

1 lb per sq in. = 170.77db (re 0.0002 microbar)

1 microbar = 74db (re 0.0002 microbar)

Section 5

SERVICE and MAINTENANCE

5.1 GENERAL. The two-year warranty given with every General Radio instrument attests the quality of materials and workmanship in our products. When difficulties do occur, our service engineers will assist in any way possible.

In case of difficulties that cannot be eliminated by the use of these service instructions, please write or phone our Service Department, giving full information of the trouble and of steps taken to remedy it. Be sure to mention the serial and type numbers of the instrument.

Before returning an instrument to General Radio for service, please write to our Service Department or nearest district office (see back cover), requesting a Returned Material Tag. Use of this tag will insure proper handling and identification. For instruments not covered by the warranty, a purchase order should be forwarded to avoid unnecessary delay.

5.2 BATTERIES. To check batteries, rotate the five-position selector switch S1 to FIL to read filament voltage and to PL for plate voltage. If the meter pointer is at or below the red mark labeled B, replace the battery.

The flashlight battery is held in place by spring clips mounted on an insulating plate. This plate is provided with banana-plug connec-

tors. Simply pull on the spring clips to unplug the whole assembly. Be careful to observe and be guided by polarity markings on the insulating plate when replacing this battery.

To remove the B battery, which is held in place by a spring, slide it out of its compartment. Snap-type contacts are used on this battery.

The filament (A) battery may be expected to give 300 hours of operation. The plate (B) battery should give 50 days of operation at two hours a day.

5.3 TROUBLE-SHOOTING.

5.3.1 METER DOES NOT READ. If there is no meter reading when a signal is applied to the input, S3 is set to QUASI PEAK, PEAK, or TIME AVG, and S1 is set to POS or NEG, check to see that input control is not set to zero.

If the meter does not read when S1 is set to FIL or PL, but does read when S1 is at POS and S3 is set to QUASI PEAK, PEAK, or TIME AVG, check resistors R13, R22, and R25.

If normal operation is experienced in some positions of S3 but not in others, check the diode rectifier for the inoperative circuit. These diodes are D1, D2, and D3 for the TIME AVG, QUASI PEAK, and PEAK circuits, respectively. Forward resistance should be about 100 ohms measured at 1 volt, back resistance at least 10^{10} ohms measured at -10 volts. If the diodes seem to be normal, check the storage capacitors (C12,

C13, C14) for leakage. C13, in the QUASI PEAK circuit, is normally shunted by 60 megohms. If no output is found in any of the three output positions, check coupling capacitor C10.

5.3.2 AMPLIFIER INOPERATIVE. Signal-tracing methods may be used to isolate the defective amplifier circuits. The over-all gain of the amplifier is about 20 db. An input of not more than 1 volt should give an output of 10 volts with the LEVEL control set at maximum.

An audio signal (1 kc), coupled through a 1- μ f isolating capacitor, may be connected to the base pins of Q1, Q2, and Q3 in turn. One volt or less into the base of Q1 and Q2 and about 0.15 volt into the base of Q3 should give full-scale readings on the meter. The QUASI PEAK position of S3 is the best to use, as the meter will then follow input-signal variations and not store the maximum level reached.

5.3.3 INSTRUMENT DOES NOT HOLD PEAK OR TIME AVG READINGS. When the PEAK or TIME AVG circuits do not hold the charge in the storage capacitors for a reasonable period of time, check C12 in the TIME AVG circuit and C14 in the PEAK circuit for excessive leakage. Also check diodes D1 and D3 for low back resistance. (Refer to paragraph 5.3.1.)

Excessive grid current in V1 may cause either a gain or a loss of charge in the storage capacitor, depending on which way the current is flowing. If diodes and capacitors seem normal and

the instrument does not hold PEAK or TIME AVG readings, replace V1. It is recommended that a replacement be a silicon-treated tube, and that it be aged before installation, to help reduce grid current. To age the tube, operate for at least 24 hours, with 1.25 volts on the filament, -1.5 volts bias, and enough B+ voltage to give a combined plate and screen current of about 200 microamperes. Plate and screen are tied together. With a supply voltage of +150 volts, a 680-kilohm resistor in series with the tube will provide about 200 microamperes of current.

Excessive temperature and humidity close to 100% may also limit the ability of the instrument to hold the charge.

5.4 TRANSISTOR CHECKS. Transistors used in this instrument should meet the following requirements:

- a. β (current gain, base to collector) should be from 40 to 100.
- b. I_{CO} (base-to-collector leakage current with emitter circuit open) should be less than 5 microamperes with -12 volts at 25 degrees C.
- c. Transistor Q3 in the last stage should have a product of β (current gain) times alpha cutoff frequency (f_{CO}) in cps of at least 50×10^6 .

5.5 VOLTAGE MEASUREMENTS. The following tables give tube and transistor test voltages for aid in trouble shooting.

TRANSISTOR VOLTAGES

TRAN-SISTOR	COLLECTOR (Red Dot)	BASE (Center Pin)	EMITTER
Q1	-35	-10	-10
Q2	-28	-15	-15
Q3	-25	-6	-6

TUBE VOLTAGES

TUBE (Type)	PIN NO.				
	1	2	3	4	5
V1 (CK6418)	+45	+45	+15	+11	+14

NOTES: B battery voltage is 45 volts.

Transistor measurements: use high side of C1 (B+) as reference.

Tube measurements: use low side of C1 (B-) as reference.

Above measurements made with dc vacuum-tube voltmeter with input resistance of 10 megohms.

Deviation of 20 percent from the above values should not be considered abnormal.

Section 6
PARTS LIST

GR No.
(NOTE A)

RESISTORS (NOTE B)	R1	100 k	±10%	POSC-11
	R2	180 k	±5%, 1/2 w	REC-20BF
	R3	50 k	±1%, 1/4 w	REF-65
	R4	25 k	±1%, 1/4 w	REF-65
	R5	30 k	±1%, 1/4 w	REF-65
	R6	620 k	±5%, 1/2 w	REC-20BF
	R7	300 k	±5%, 1/2 w	REC-20BF
	R8	22 k	±5%, 1/2 w	REC-20BF
	R9	8.2 k	±5%, 1/2 w	REC-20BF
	R10	39 k	±5%, 1/2 w	REC-20BF
	R11	220 k	±5%, 1/2 w	REC-20BF
	R12	180 k	±5%, 1/2 w	REC-20BF
	R13	27 k	±1%, 1/4 w	REF-65
	R14	5 k	±1%, 1/4 w	REF-65
	R15	15 k	±5%, 1/2 w	REC-20BF
	R16	1.8 k	±5%, 1/2 w	REC-20BF
	R17	100 k	±5%, 1/2 w	REC-20BF
	R18	50 k	±1%, 1/4 w	REF-65
	R19	125 k	±1%, 1/4 w	REF-65
	R20	20 k	±1%, 1/4 w	REF-65
	R21	500 k	±1%, 1/4 w	REF-65
	R22	18 k	±1%, 1/4 w	REF-65
	R23	710 k	±1%, 1/4 w	REF-65
	R24	6.2 k	±1%, 1/4 w	REF-65
	R25	22	±5%, 1/2 w	REC-20BF
	R26	10 k	±10%	POSC-11

Parts List (Cont.)

GR No.
(NOTE A)

RESISTORS (NOTE B)	R27	27 k	±5%, 1/2 w	REC-20BF
	R28	60 k	±1%, 1/4 w	REF-65
	R29	10 k	±1%, 1/4 w	REF-65
	R30	25 k	±1%, 1/4 w	REF-65
	R31	50 k	±1%, 1/4 w	REF-65
	R32	50 k	±1%, 1/4 w	REF-65
	R33	250 k	±1%, 1/4 w	REF-65
	R34	500 k	±1%, 1/4 w	REF-65
	R35	500 k	±1%, 1/4 w	REF-65
	R36	15 k	±5%, 1/2 w	REC-20BF
	R37	62 M	±5%, 1/2 w	REC-20BF
	R40	1 M	±5%, 1/2 w	REC-20BF
	R41	15 M	±5%, 1/2 w	REC-20BF
	CAPACITORS (NOTE C)	C1	50	+100%-10%, 50 dcwv
C2		1	±10%, 100 dcwv	COW-17
C3		1	±10%, 100 dcwv	COW-17
C4		1	±10%, 100 dcwv	COW-17
C5		10	+100%-10%, 50 dcwv	COE-49
C6		10	+100%-10%, 50 dcwv	COE-49
C7		0.1	±10%, 100 dcwv	COW-17
C8		10	+100%-10%, 50 dcwv	COE-49
C9		100	+100%-10%, 15 dcwv	COE-46
C10		3.3	±10%, 100 dcwv	COP-24
C11		10	+100%-10%, 50 dcwv	COE-49
C12		0.2	±5%, 100 dcwv	COW-17
C13		0.01	±5%, 100 dcwv	COW-17
C14		0.022	±10%, 100 dcwv	COW-17
C15		47 μmf	±10%, 500 dcwv	COM-20B

Parts List (Cont.)

GR No.
(NOTE A)

MISCELLANEOUS	B1	BATTERY, 1½ v, Rayovac Type 2LP or equivalent	
	B2	BATTERY, 45 v, Burgess Type XX30 or equivalent	
	D1	DIODE	1N300
	D2	DIODE	1N300
	D3	DIODE	1N300
	M1	METER	MEDS-73
	PL1	PLUG	CDMP-22
	S1	SWITCH	SWRW-2760
	S2	SWITCH	SWRW-2770
	S3	SWITCH	SWRW-2780
	S4	SWITCH	SWT-9
	Q1	TRANSISTOR	2N1372
	Q2	TRANSISTOR	2N1372
Q3	TRANSISTOR	2N1374	

NOTES

- (A) Type designations for resistors and capacitors are as follows:
- COE - Capacitor, electrolytic
 - COM - Capacitor, mica
 - COW - Capacitor, wax
 - POSC - Potentiometer, composition
 - REC - Resistor, composition
 - REF - Resistor, film
- (B) All resistances are in ohms unless otherwise specified by k (kilohms) or M (megohms)
- (C) All capacitances are in microfarads unless otherwise specified by $\mu\mu f$ (micromicrofarads)

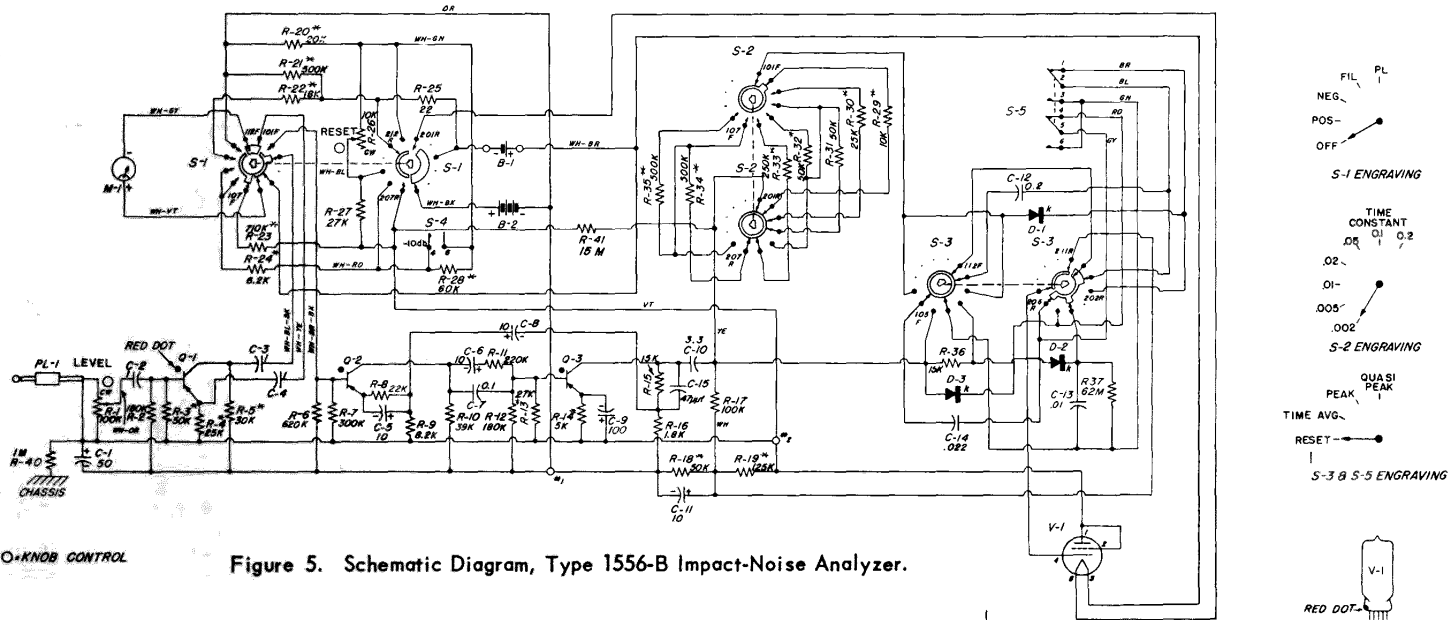

O-KNOB CONTROL

Figure 5. Schematic Diagram, Type 1556-B Impact-Noise Analyzer.

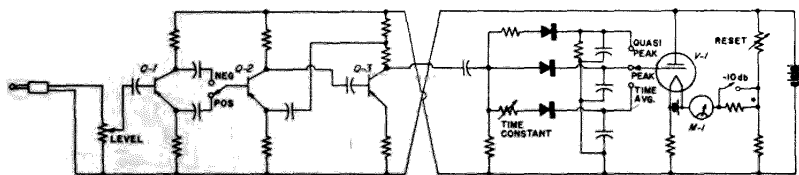
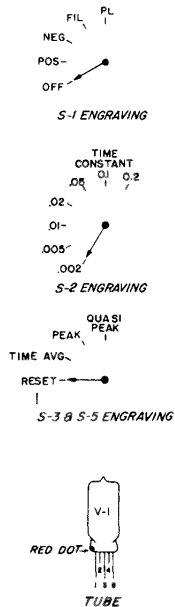
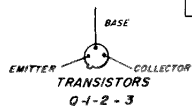
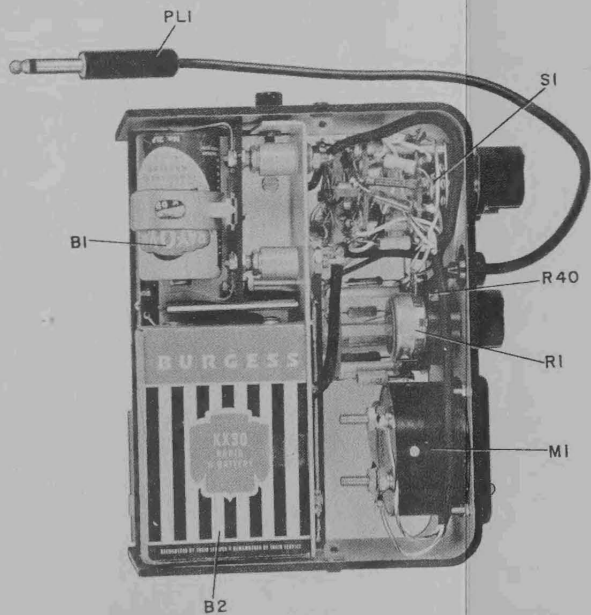

Figure 6. Simplified Schematic Diagram



**BASE OF V1 TUBE TO BE COATED WITH G.E. DRYFILM SC87 G.R. CO. NO. TUE-2



B2

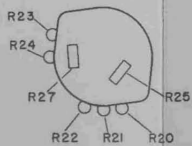

S-1

Figures 7 and 8.
Interior Views. (Insets show
rear views of switches.)

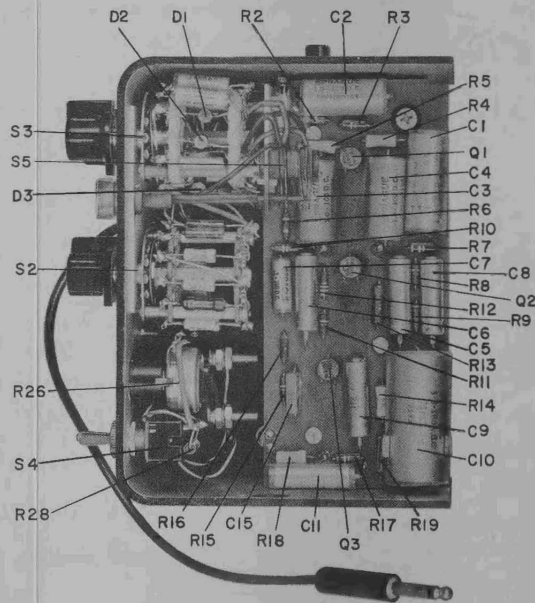

D2

D1

R2

C2

R3

S3

S5

D3

S2

R25

S4

R28

R16

R15

R18

C11

Q3

R17

R19

R5

R4

C1

Q1

C4

C3

R6

R10

R7

C7

R8

R9

C6

C5

R13

R11

R14

C9

C10

R37

R38

R39

D2

D1

C12

D3

C14

R36

S-2

S-3

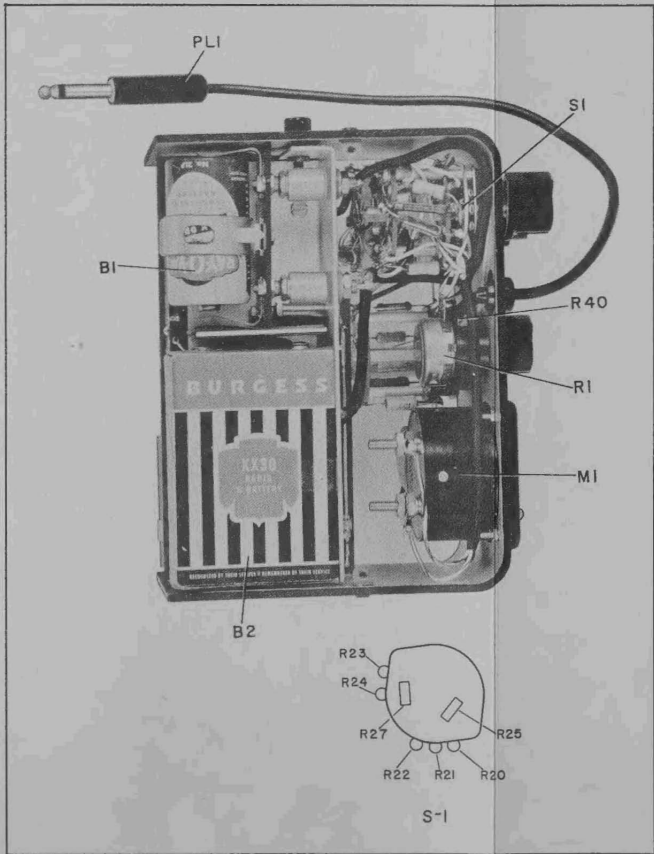

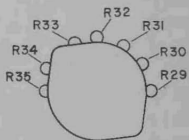
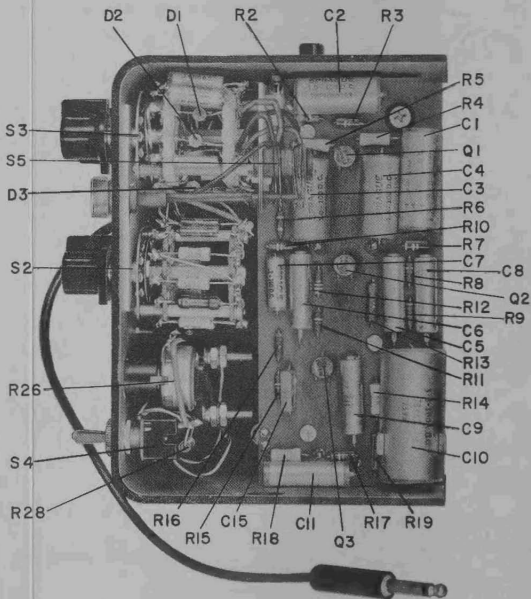

S-2

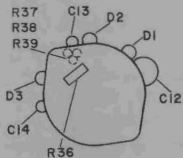

S-3

GENERAL RADIO COMPANY

WEST CONCORD, MASSACHUSETTS 01781

617 369-4400

617 646-7400

SALES ENGINEERING OFFICES

NEW ENGLAND*

22 Baker Avenue
West Concord, Massachusetts 01781
Telephone 617 646-0550

METROPOLITAN NEW YORK*

Broad Avenue at Linden
Ridgefield, New Jersey 07657
Telephone N.Y. 212 964-2722
N.J. 201 943-3140

SYRACUSE

Pickard Building
East Molloy Road
Syracuse, New York 13211
Telephone 315 454-9323

PHILADELPHIA

Fort Washington Industrial Park
Fort Washington, Pennsylvania 19034
Telephone 215 646-8030

WASHINGTON* and BALTIMORE

11420 Rockville Pike
Rockville, Maryland 20852
Telephone 301 946-1600

ORLANDO

113 East Colonial Drive
Orlando, Florida 32801
Telephone 305 425-4671

CHICAGO*

6605 West North Avenue
Oak Park, Illinois 60302
Telephone 312 848-9400

CLEVELAND

5579 Pearl Road
Cleveland, Ohio 44129
Telephone 216 886-0150

LOS ANGELES*

1000 North Seward Street
Los Angeles, California 90038
Telephone 213 469-6201

SAN FRANCISCO

626 San Antonio Road
Mountain View, California 94040
Telephone 415 948-8233

DALLAS*

2600 Stemmons Freeway, Suite 210
Dallas, Texas 75207
Telephone 214 637-2240

TORONTO*

99 Floral Parkway
Toronto 15, Ontario, Canada
Telephone 416 247-2171

MONTREAL

1255 Laird Boulevard
Town of Mount Royal, Quebec, Canada
Telephone 514 737-3673

* Repair services are available at these offices.

General Radio Company (Overseas), 8008 Zurich, Switzerland
General Radio Company (U.K.) Limited, Bourne End, Buckinghamshire, England
Representatives in Principal Overseas Countries