

OPERATING INSTRUCTIONS



TYPE 1204-B UNIT VARIABLE POWER SUPPLY



GENERAL RADIO COMPANY
CAMBRIDGE 39, MASSACHUSETTS, USA



TYPE 1204-B UNIT

VARIABLE POWER SUPPLY

1 INTRODUCTION.

1.1 PURPOSE. The Type 1204-B Unit Variable Power Supply (Figure 1) is a convenient source of adjustable d-c plate voltage and fixed a-c heater voltage. It can be attached directly to other Unit instruments, and supplies instruments not of the Unit line through jack-top binding posts or by means of a mating connector provided.

1.2 DESCRIPTION.

1.2.1 CONTROLS. The POWER toggle switch is used to turn the instrument on or off, and the pilot light adjacent glows to signify application of power. The setting of the METER toggle switch determines whether the meter indicates output voltage (in volts) or output current (in milliamperes). The knob at the right-hand side of the front panel controls the d-c output voltage.

1.2.2 CONNECTIONS. Plate and heater voltages are available both at front-panel binding posts and at the multipoint connector on the right-hand side of the instrument. The multipoint connector receives a mating plug provided on other Unit instruments, or can be adapted to other connections through a mating plug supplied. When using the mating plug supplied, connect it as follows:

terminals 13 and 14: 6.3 v ac
terminals 15 and 16: 0-300 v dc (terminal 15 positive).

The four insulated binding posts on the panel are, from left to right: two 6.3-v a-c, negative (black) d-c and positive (red) d-c terminals.

Both the 6.3-v a-c and 0-300-v d-c supplies are isolated from ground and from each other to permit greater latitude in external connections.

2 CIRCUIT. The high-voltage secondary of the power transformer is connected to a Type 200-B Variac, and thence through two selenium rectifiers in a voltage-doubling circuit to provide a d-c output from 0 to 300 volts at a maximum load of 100 milliamperes. For circuit details, see the schematic diagram, Figure 2.

3 OPERATION. With the POWER switch ON and the METER switch at VOLTS, set the output control to the desired output voltage as indicated on the meter. To determine the output current, set the METER switch to MILLIAMPERES. The output current must not exceed 100 milliamperes.



CAUTION

Due to the large amount of capacitance in the d-c output circuit, the resultant time constant is appreciable for small d-c loads. Consequently, if the output control setting is reduced, the time required for the voltage to assume its new value can easily be a matter of seconds. Do not attempt to hasten the change by shunting the d-c terminals with a resistance less than 1500 ohms; current due to the residual charge in output capacitance can be great enough to blow the output fuse.

4 SERVICE AND MAINTENANCE.

4.1 GENERAL. Major service problems should be referred to our Service Department, which will cooperate as much as possible by furnishing information and instructions as well as by supplying any replacement parts needed.

When notifying our Service Department of any difficulties in operation or service, specify the serial and type numbers of the instrument. (The serial number is stamped on the inside of the instrument.) Also give a complete report of trouble encountered and steps taken to eliminate the trouble.

Before returning an instrument or part for repair, please write to our Service Department, requesting a Returned Material Tag, which includes shipping instructions. Use of this tag will insure proper handling and identification. A purchase order covering repair of material returned should also be forwarded to avoid unnecessary delay.

4.2 FUSES. The Type 1204-Buses two 1.25-ampere Slo-Blo fuses in the input and a 0.25-ampere fuse in the d-c output circuit.

4.3 COVER REMOVAL. To remove the cover, loosen the black thumb-screw on the left-hand side of the cabinet and slide the cover off, away from the panel.

SPECIFICATIONS

Output Voltages:	0 - 300 v dc at 100 ma max, adjustable. 400 v dc max no-load voltage. 6.3 v ac at 3 amp max.
Hum Level:	Approx 250 mv at 300-v, 100-ma d-c load; approx 150 mv at 350-v, 50-ma d-c load.
Input:	115 v, 60 cps. Power consumption 75 w at full load.
Accessories Supplied:	Multipoint connector and spare fuses.
Mounting:	Black-crackle-finish aluminum panel and sides. Aluminum cover finished in clear lacquer.
Dimensions:	Width 9-7/8 in., height 5-3/4 in., depth 6-1/4 in., over-all, not including power cord.
Weight:	9-3/4 lb.

GENERAL RADIO EXPERIMENTER reference: Vol XXVI No. 2, July 1951.



Figure 2. Schematic Diagram.

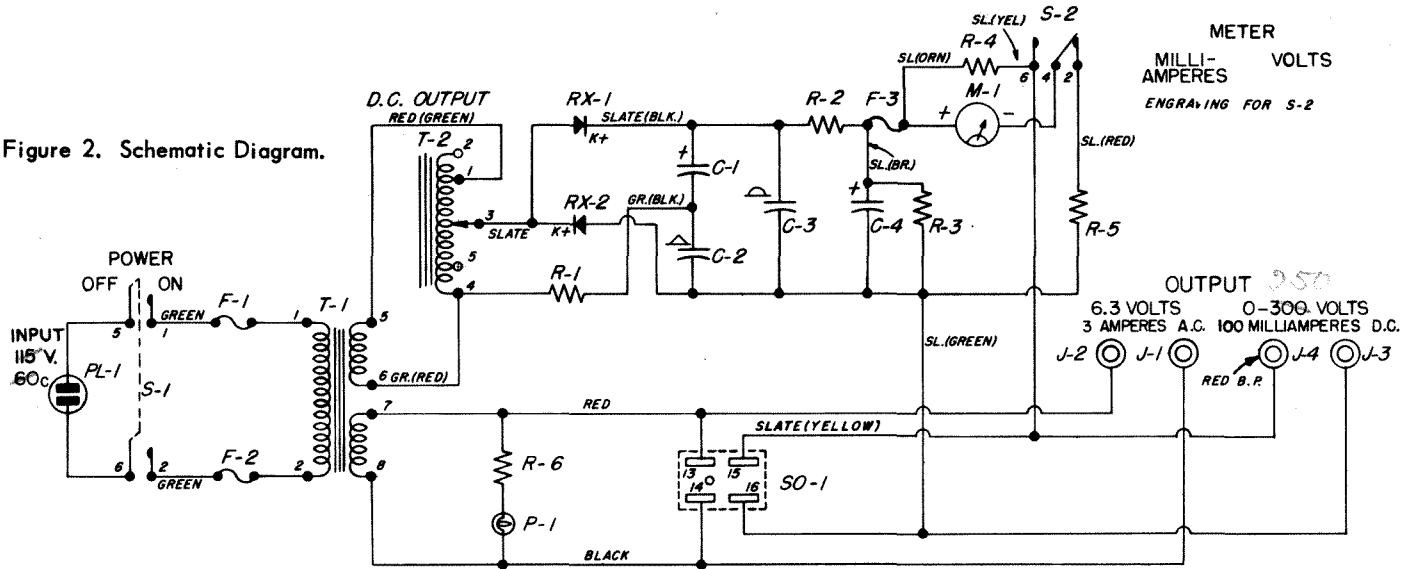

	DESCRIPTION	PART NO.		DESCRIPTION	PART NO.
C1	CAPACITOR, Electrolytic, 40 μ f, 200 dcwv	COE-29	R3	RESISTOR, Composition, 220k \pm 10%, 1w	REC-30BF
C2	CAPACITOR, Electrolytic block, 40 μ f, 200 dcwv	COEB-29	R4	RESISTOR, Precision, 1 ohm \pm 1%	ZREPR-1
C3	CAPACITOR, Electrolytic block, 60 μ f, 400 dcwv		R5	RESISTOR, Film, 400k \pm 1%, 1/2 w	REF-1
C4	CAPACITOR, Electrolytic block, 2x40 μ f, 450 dcwv	COEB-17	R6	RESISTOR, Wire-wound, 15 ohms \pm 10%, 1/2 w	REW-3C
F1	FUSE, 1.25 amp Slo-Blo Type 3AG	FUF-1	RX1	RECTIFIER, 150 ma	2RE-11
F2	FUSE, 1.25 amp Slo-Blo Type 3AG	FUF-1	RX2	RECTIFIER, 150 ma	2RE-11
F3	FUSE, 0.25 amp Type 3AG	FUF-2	S1	SWITCH, dpst	SWT-333
M1	METER, 1ma, 100 ohms	MEDS-47	S2	SWITCH, spdt	SWT-320
P1	PILOT LIGHT, 6.3v, Mazda #44	2LAP-939	T1	TRANSFORMER	485-474-1
R1	RESISTOR, Power, 20 ohms \pm 10%	REPO-16-2	T2	VARIAC [®]	200-B
R2	RESISTOR, Wire-wound, 160 ohms \pm 5%, 2w	REW-6C			622-405

