

OPERATING INSTRUCTIONS



# TYPE **1750-A**

## SWEEP DRIVE

1750-A

G E N E R A L R A D I O C O M P A N Y



# OPERATING INSTRUCTIONS

## TYPE **1750-A**

---

### SWEEP DRIVE

Form 1750-0100-C  
May, 1961

G E N E R A L R A D I O C O M P A N Y  
WEST CONCORD, MASSACHUSETTS, USA



## TABLE OF CONTENTS

	Page
Section 1. INTRODUCTION . . . . .	1
1.1 Purpose . . . . .	1
1.2 Description . . . . .	1
1.3 Operating Limits . . . . .	4
1.4 Output Regulation . . . . .	4
1.5 Comparison with Sweep Oscillators . . . . .	5
Section 2. INSTALLATION . . . . .	5
2.1 General . . . . .	5
2.2 Coupling Sweep Drive to Driven Instrument . . . . .	7
2.3 Limit Switch Adjustment . . . . .	7
2.4 Center-of-Sweep Adjustment . . . . .	8
2.5 Connections . . . . .	8
Section 3. OPERATING PROCEDURE . . . . .	8
3.1 Start-up Procedure . . . . .	8
3.2 During Operation . . . . .	8
3.3 Blanking Circuit . . . . .	8
3.4 Deflection Voltage . . . . .	8
3.5 Backlash . . . . .	8
3.6 Calibration Transfer . . . . .	9
Section 4. SERVICE AND MAINTENANCE . . . . .	9
4.1 General . . . . .	9
4.2 Lubrication . . . . .	9
4.3 Drive Belts . . . . .	9
4.4 Deflection Rheostat . . . . .	9
Section 5. PARTS LIST . . . . .	11

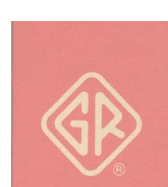

# SPECIFICATIONS

## Reciprocating Output Shaft

<b>Center Position</b>	Adjustable within 9 turns
<b>Sweep Arc</b>	Adjustable from 30 to 300°
<b>Torque</b>	Rated max 24 ounce-inches
<b>Sweep Speed</b>	Adjustable 0.5 to 5 cps. (Moment of inertia of load limits max safe speed.)
<b>Shaft Height</b>	Adjustable from 2-1/2 to 4-7/8 in. above bench

## Flexible Coupling

<b>Length</b>	5-3/4 inches
<b>Coupling Limits</b>	Shaft diameters: 1/4 and 3/8 in.; knobs and dials from 1 to 4 in.

**Limit Switch** One limit fixed, the other adjustable within 9 turns

**Sweep Voltage** 2.5 v peak to peak, ungrounded

**Blanking** Shorting contact closed during clockwise rotation of driven shaft; ungrounded

**Input Power** 115 v, 50-60 cps, 60 watts

**Dimensions:** Width 17-1/2, height 9, depth 8-1/4 inches (445 by 230 by 210 mm).

**Net Weight:** 22-1/2 lb (10.3 kg).

U. S. PATENT NO. 2,949,592

The oscillators listed below are recommended for use with the Type 1750-A Sweep Drive for automatic sweeping over the ranges indicated.

<u>Type</u>	<u>Frequency Range</u>
1211-B	0.5-5 and 5-50 Mc
1215-B	50-250 Mc
1209-B	250-920 Mc
1209-BL	180-600 Mc
1208-B	65-500 Mc
1361-A	450-1050 Mc
1218-A	900-2000 Mc

Types 1208-B and 1218-A have sliding contacts in the tuned circuit and are recommended for limited use at slow speed. The output of the Type 1208-B cannot be regulated by the Type 1263-B Amplitude-Regulating Power Supply (see below). Older models, Types 1208-A, 1209-A, and 1215-A have no ball bearings and have stops and dial indicators which require some attention during automatic sweeping.

To maintain constant output at all frequencies during the sweep, the Type 1263-B Amplitude-Regulating Power Supply is recommended. This instrument varies the plate voltage of connected oscillators to maintain preset output. Type 874-VR Voltmeter Rectifier and Type 874-R22 Patch Cord are required accessories. All recommended oscillators, when connected to a 50-ohm load, will deliver an output of 1 volt, with a source impedance of 50 ohms. Level of regulated output voltage (behind 50 Ω) is indicated on panel meter.

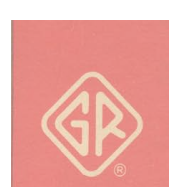

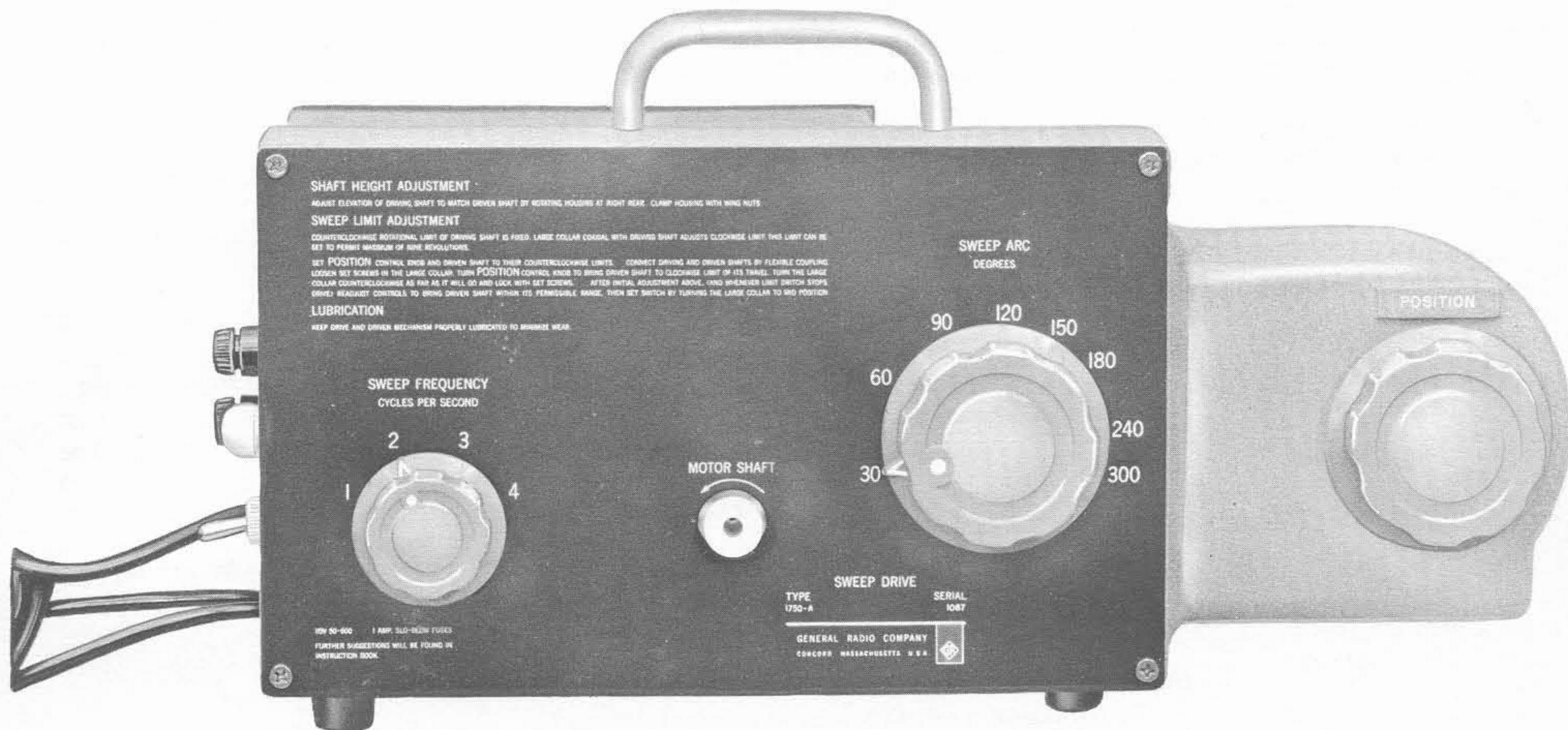

Figure 1. Panel View, Type 1750-A Sweep Drive.

# TYPE 1750-A SWEEP DRIVE

## Section 1

### INTRODUCTION

1.1 PURPOSE. The Type 1750-A Sweep Drive (see Figure 1) is an electromechanical device used to turn shafts, knobs, or dials in reciprocating motion at speeds from 0.5 to 5 cycles per second. Such an automatic drive is particularly useful in adapting manually operated equipment to automatic sweep applications. The Sweep Drive is an essential component in many automatic data display systems. It is used as an artificial hand, for instance, to turn an oscillator back and forth over a desired frequency range and to provide a horizontal sweeping voltage, proportional to shaft rotation, for deflection of a cathode-ray oscilloscope.

#### 1.2 DESCRIPTION.

1.2.1 GENERAL. The principal parts of the Type 1750-A Sweep Drive are mounted on a cast aluminum housing (see Figures 2, 3, and 4). A 5000-rpm, 230-v, universal motor (1, Fig. 4) operates with a fixed field supply and from a reduced armature voltage that can be varied by the SWEEP FREQUENCY control. This motor drives a crank through two belts (2) to effect the required speed reduction. A connecting rod (2,

Fig. 4) operated by the crank, is connected to one end of an adjustable rack (3). At the other end of the rack a second connecting rod (4) operates through a differential to turn the output shaft (5). The point about which the rack pivots is adjusted by the SWEEP ARC control, and the setting of this control determines the size of the arc swept. The output or drive shaft can be swung around the center of the round housing (6) to match the height of the driven shaft. The cylindrical housing (7) around the output shaft is used to adjust the limit switch, which stops the motor if a predetermined excursion of the shaft is exceeded.

For an oscilloscope, horizontal deflection voltage, proportional to the sweep arc, is obtained from a potentiometer (3, Fig. 3), which is driven by a fixed crank. Because of the geometry of the various linkages, the relation between shaft deflection and deflection voltage is almost linear in one direction but does not repeat on the return trace. A blanking contact (10, Fig. 4) suppresses the return trace and replaces it with a zero reference axis.

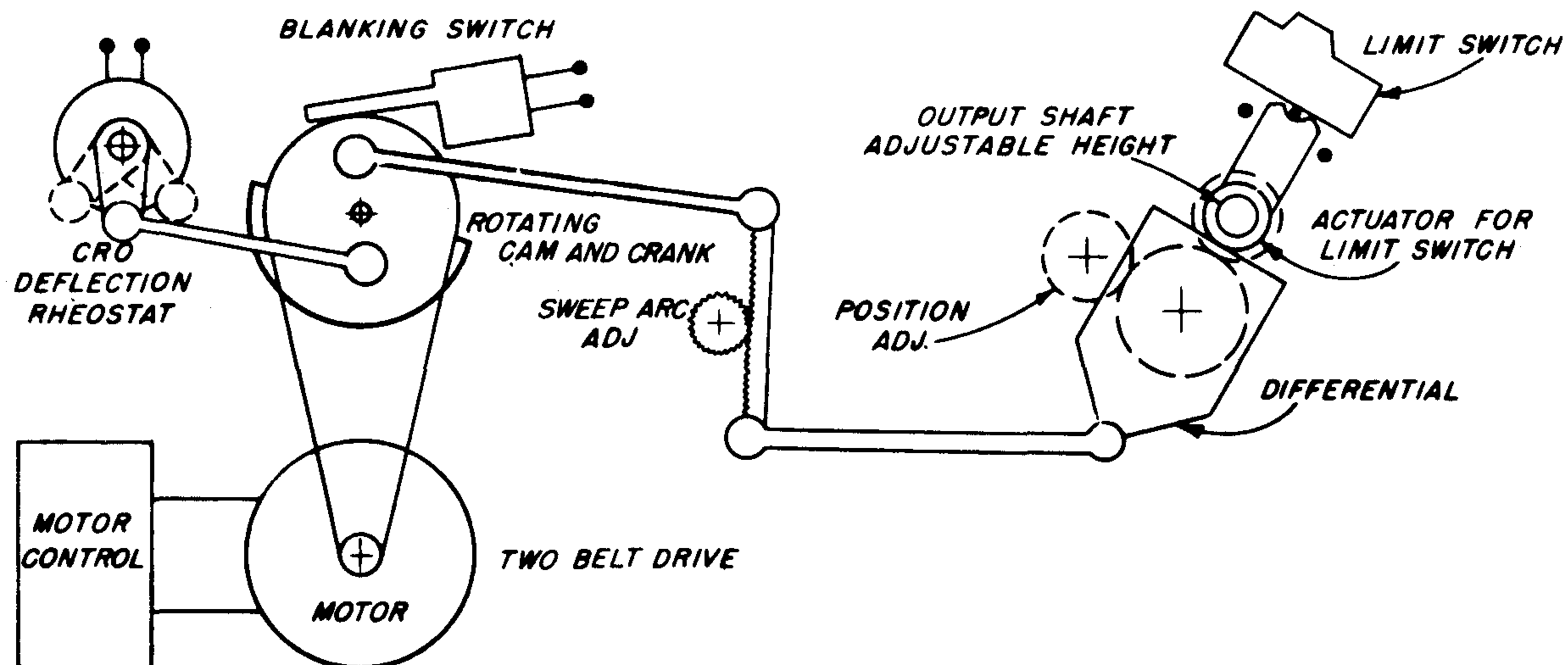

Figure 2. Elementary Mechanical Diagram.

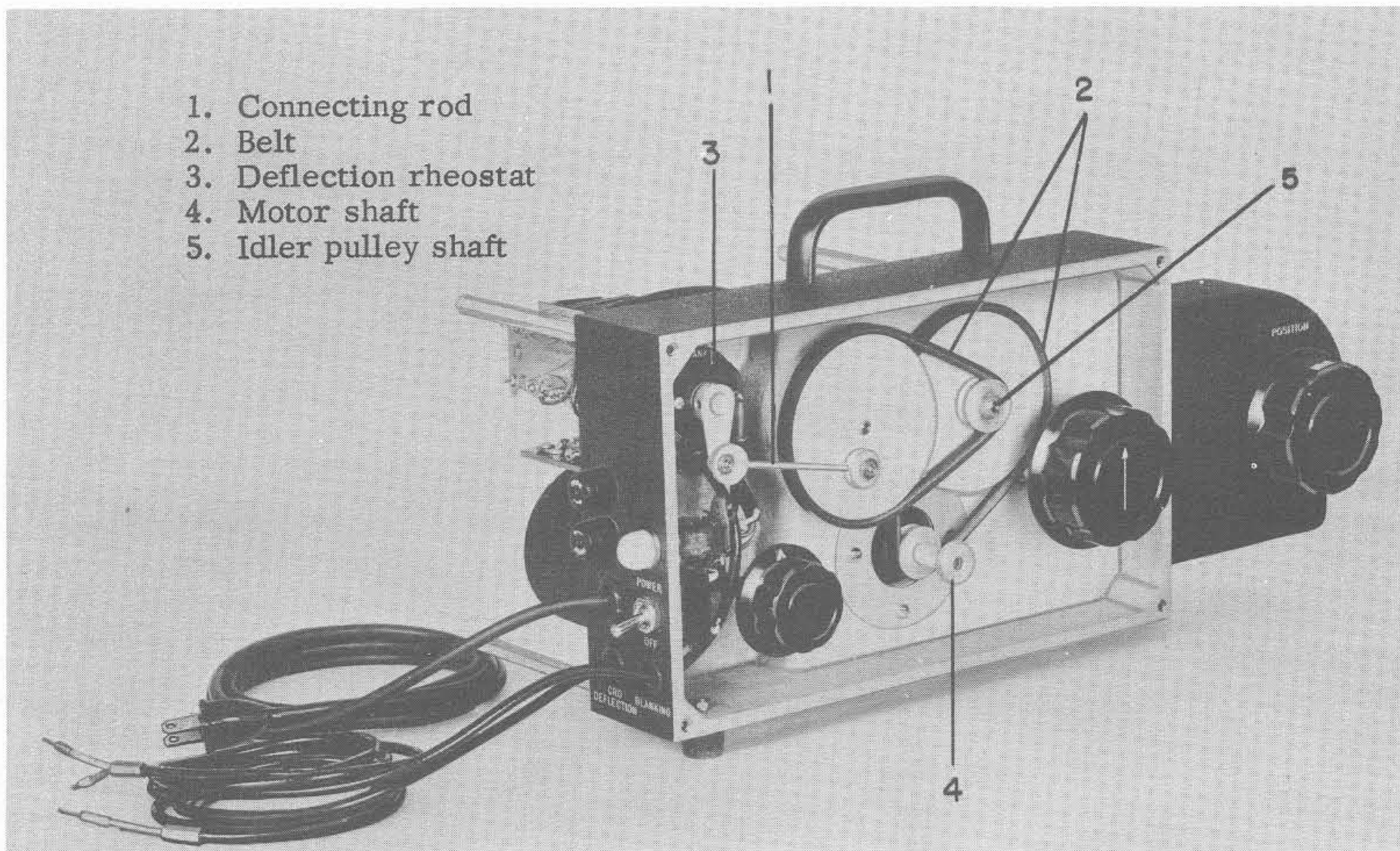
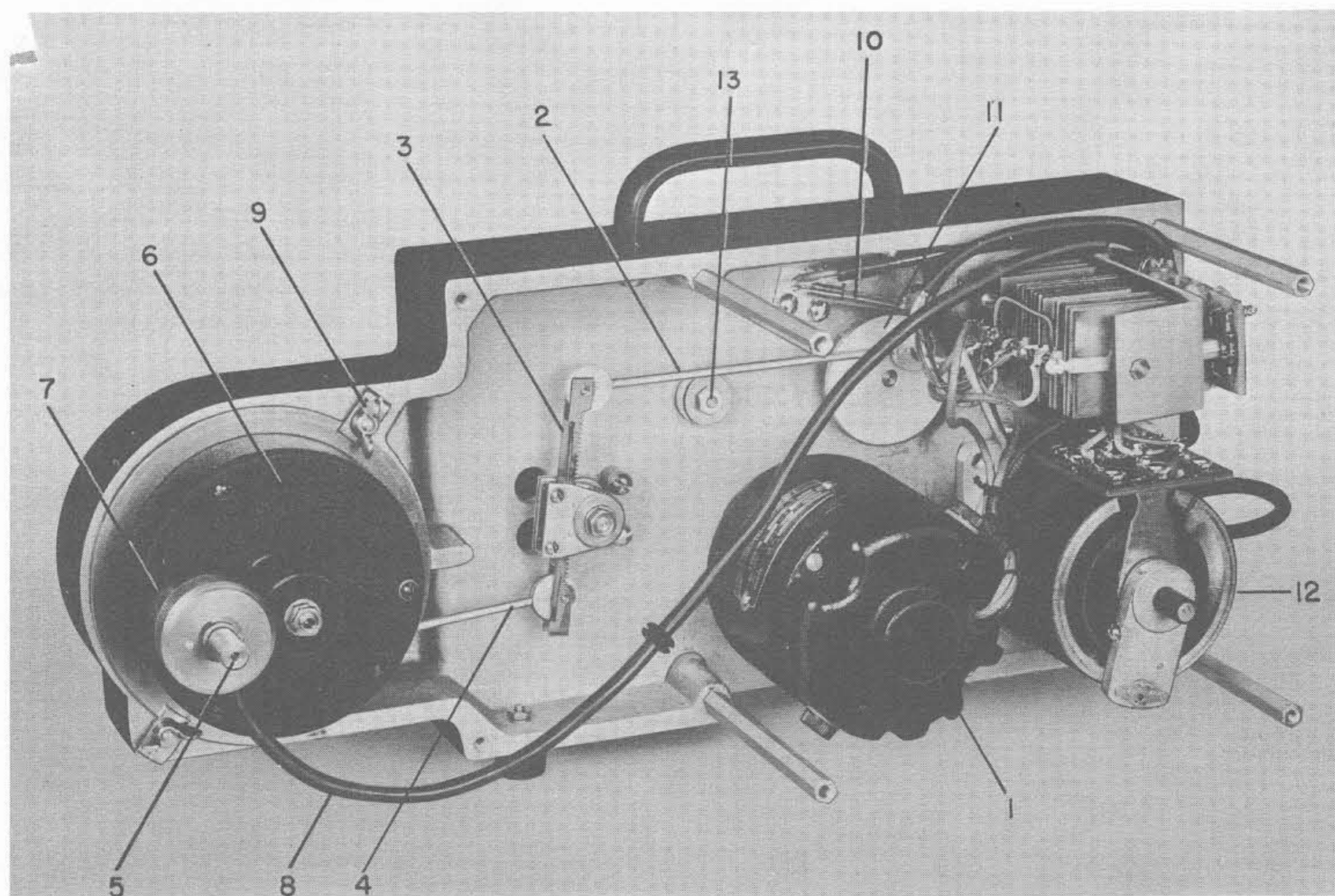

Figure 3. Front Interior View.



- |                    |                         |                                      |
|--------------------|-------------------------|--------------------------------------|
| 1. Motor           | 6. Rotating housing     | 11. Blanking cam                     |
| 2. Connecting rod  | 7. Limit switch housing | 12. Variac (Sweep frequency control) |
| 3. Adjustable rack | 8. Limit switch cable   | 13. Idler pulley nut                 |
| 4. Connecting rod  | 9. Wing nuts            |                                      |
| 5. Output shaft    | 10. Blanking contact    |                                      |

Figure 4. Rear Interior View.

## TYPE 1750-A SWEEP DRIVE

Figure 5, a series of multiple-exposure photographs, shows the sliding rack in different positions and illustrates how the sweep arc is changed from 30 to 300 degrees by adjustment of the rack pivot point. The differential at the left sweeps only one quarter of this angle.

**1.2.2 CALIBRATION.** Since the cathode-ray oscilloscope deflection voltage is proportional to shaft rotation, the frequency distribution on the oscilloscope screen repeats the frequency distribution of a swept oscillator. However, actual frequencies corresponding to screen ordinates depend on the SWEEP ARC and POSITION settings. At times, accurate crystal-controlled markers may be desirable, but for most applications the limited resolution of the oscilloscope trace justifies only moderate accuracy. By transferring the oscillator calibration to the screen, one can obtain accuracies comparable to the calibration accuracy of the swept oscillator. To facilitate this transfer, the end of the motor shaft (4, Fig. 3) is extended through the front panel of the Sweep Drive for slow manual turning.

**1.2.3 CIRCUITS.** The Type 1750-A Sweep Drive has three independent electrical circuits: (1) the speed control and limit switch circuit, which controls the motor; (2) the CRO deflection circuit, which provides a voltage proportional to shaft position; and (3) the blanking circuit, which eliminates the return trace.

**1.2.3.1 Motor.** The high-speed motor requires a large speed reduction, obtained by the two belts. The stored energy of the rotor helps overcome the fluctuating torque requirements of the reciprocating motion. To obtain satisfactory operation over the 10-to-1 speed range, field and armature supplies are rectified. The field is constant, practically at saturation level, and the armature voltage is controlled by a Variac<sup>®</sup> autotransformer.

**1.2.3.2 Limit Switch.** The limit switch, located near the output shaft on the differential housing, is connected by a flexible cable (8, Fig. 4). This switch permits reciprocal rotation of the output shaft between two limits. One limit is fixed, the other can be adjusted to allow up to nine turns of the output shaft. This wide range is useful when connection is made to the slow-motion drive of an oscillator. For fast stopping, the limit switch disconnects the armature from the supply and shorts it by a brake resistor.

**1.2.3.3 CRO Deflection Voltage.** The CRO deflection voltage is obtained from a secondary winding on the Variac. A periodically varying voltage of about 2.5 volts peak to peak is provided at the end of the deflection cable.

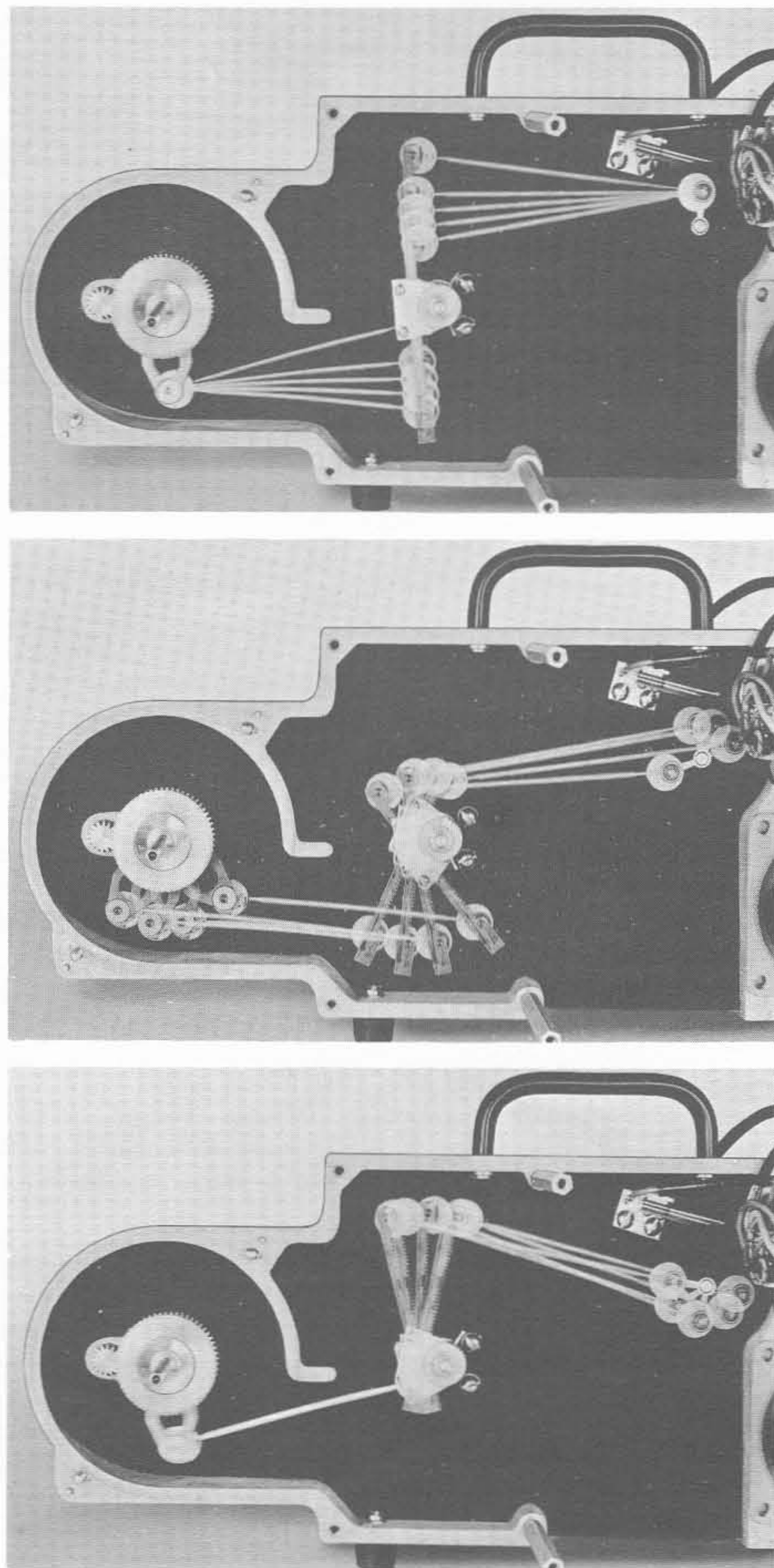

Figure 5. Multiple-Exposure Views Showing Action of Sliding Rack. Top: Center of stroke, showing range of rack adjustment. Middle: Action at maximum sweep arc. Bottom: Action at minimum arc.

**1.2.3.4 Blanking Circuit.** A shorting contact, closed during clockwise shaft rotation, is connected to the blanking cable, which can be connected to the oscilloscope vertical deflection terminals to prevent deflection during the return trace. This circuit also can be used to reduce oscillator output to zero. The return trace is then a zero reference line.



## GENERAL RADIO COMPANY

1.2.4 CONTROLS. The following controls are on the panel of the Type 1750-A Sweep Drive:

<u>Name</u>	<u>Markings</u>	<u>Function</u>
SWEEP FREQUENCY	1, 2, 3, 4 (cps)	Controls sweep speed
SWEEP ARC	30, 60, 90, 120, 150, 180, 240, 300 (degrees)	Controls angle of sweep
MOTOR SHAFT	Arrow indicating di- rection of rotation	Permits slow manual turning
POSITION	None	Selects portion of range to be swept
POWER (left side)	POWER, OFF	Energizes Sweep Drive

1.2.5 CONNECTIONS. The following cables are attached to the left side of the instrument housing:

<u>Name</u>	<u>Function</u>
POWER	Connection to power line
CRO DEFLECTION	Connection to horizontal de- flection terminals of CRO
BLANKING	Elimination of return trace

1.2.6 FUSES. There are two fuses used with the Sweep Drive, both mounted on the left side of the instrument housing. The upper (motor armature) fuse and the lower (line) fuse are both 1-ampere, Slo-Block-type fuses.

1.3 OPERATING LIMITS. The Sweep Drive is used primarily to drive r-f oscillators for automatic presentation of frequency response curves on a cathode-ray oscilloscope. Although the Sweep Drive can be driven at speeds up to five cycles per second, lower speeds should normally be used to prevent damage to equipment not designed for rapid mechanical turning. At slow speeds, wear is no greater than with hand turning, and the trace produced is very satisfactory if a long-persistence screen is used. At speeds up to five cycles per second the eye can follow the writing spot easily, without the sensation of flicker. Since a complete cycle takes appreciable time at slow sweep speeds, changes made on the equipment under test do not show immediately on the oscilloscope pattern. This delayed response is the only disadvantage of slow sweep speeds.

The forces acting on the driven device increase with the moment of inertia of the moving parts and with their angular acceleration. Since acceleration increases with the square of the sweep frequency, the forces increase 1000 to 1 when controls are

changed from 30 degrees at 0.5 cycle per second to 300 degrees at five cycles per second. In most applications, sweep arc is determined by the measurement requirements, while sweep speed is arbitrary. To reduce delay, there is a temptation to use high speeds, but the higher speeds are best used only with small arcs, with speed being decreased as the arc is increased.

In reciprocating motion, forces vary harmonically and reverse gradually twice during each cycle. In practice, small clearances between shafts and bearings prevent a gradual reversal. This small play, which can never be eliminated, causes backlash in manual operation and pounding in the motor drive. The rated maximum torque of the drive shaft is 24 ounce-inches. No definite limit can be specified for the accelerating forces; their effect can be estimated by the amount of pounding they cause. As protection for the driven device, the differential includes a friction device, associated with the POSITION control, which slips under excessive force. The friction can be controlled in assembly and has been set to hold about five times the rated torque.

The moment of inertia of a flat dial is proportional to its weight and the square of its diameter. Large dials and knobs add considerably to the inertia of a driven load, and should be removed if this can be done without loss of calibration of the instrument. For instance, a brass dial six inches in diameter and 1/16 inch thick will cause the friction clutch to slip if driven more than one cycle per second over an arc of 300 degrees.

1.4 OUTPUT REGULATION. An important requirement of any sweep generator is that the output voltage be constant with frequency, since any variation

## TYPE 1750-A SWEEP DRIVE



Figure 6. Type 1750-A Sweep Drive, Type 1263-B Amplitude-Regulating Power Supply, and Type 1208-B Unit Oscillator in Typical Setup.

appears as part of the displayed curve. The problem of maintaining an adequate degree of flatness of output increases with the range to be covered. For wide sweep ranges, output regulation is usually necessary. General Radio oscillators operate from separate power supplies, and are easily adapted to output regulation. The Type 1263 Amplitude Regulating Power Supply is designed primarily for use with these oscillators to maintain constant output. Figure 6 shows a

typical arrangement. (The oscillator is the Type 1208-B Unit Oscillator.)

1.5 COMPARISON WITH SWEEP OSCILLATORS. Sweep oscillators, built specifically for presentation of frequency-response curves, have few, if any, moving parts, and can operate at speeds where flicker and delay are no problems. The Sweep Drive is uniquely useful with wide-range high-frequency oscillators, particularly with General Radio oscillators.

## Section 2

### INSTALLATION

2.1 GENERAL. The instructions on the front panel of the Type 1750-A Sweep Drive are intended merely as a guide, and should not be considered sufficient for anyone who has never used the instrument. Smooth, efficient operation of the Sweep Drive is impossible unless the driven knob, shaft, or dial is properly connected to the Sweep Drive output shaft, and unless the limit switch is set correctly. The operator should be able to observe oscilloscope patterns

and to handle controls without paying any attention to mechanical limits. If the limit switch is set properly, full attention can be given to the automatic data display, and center frequency and sweep range of a Unit Oscillator can be set as conveniently on the Sweep Drive as on any Sweep Oscillator.

Before operating the instrument, remove front and rear panels and study the functions of mechanical

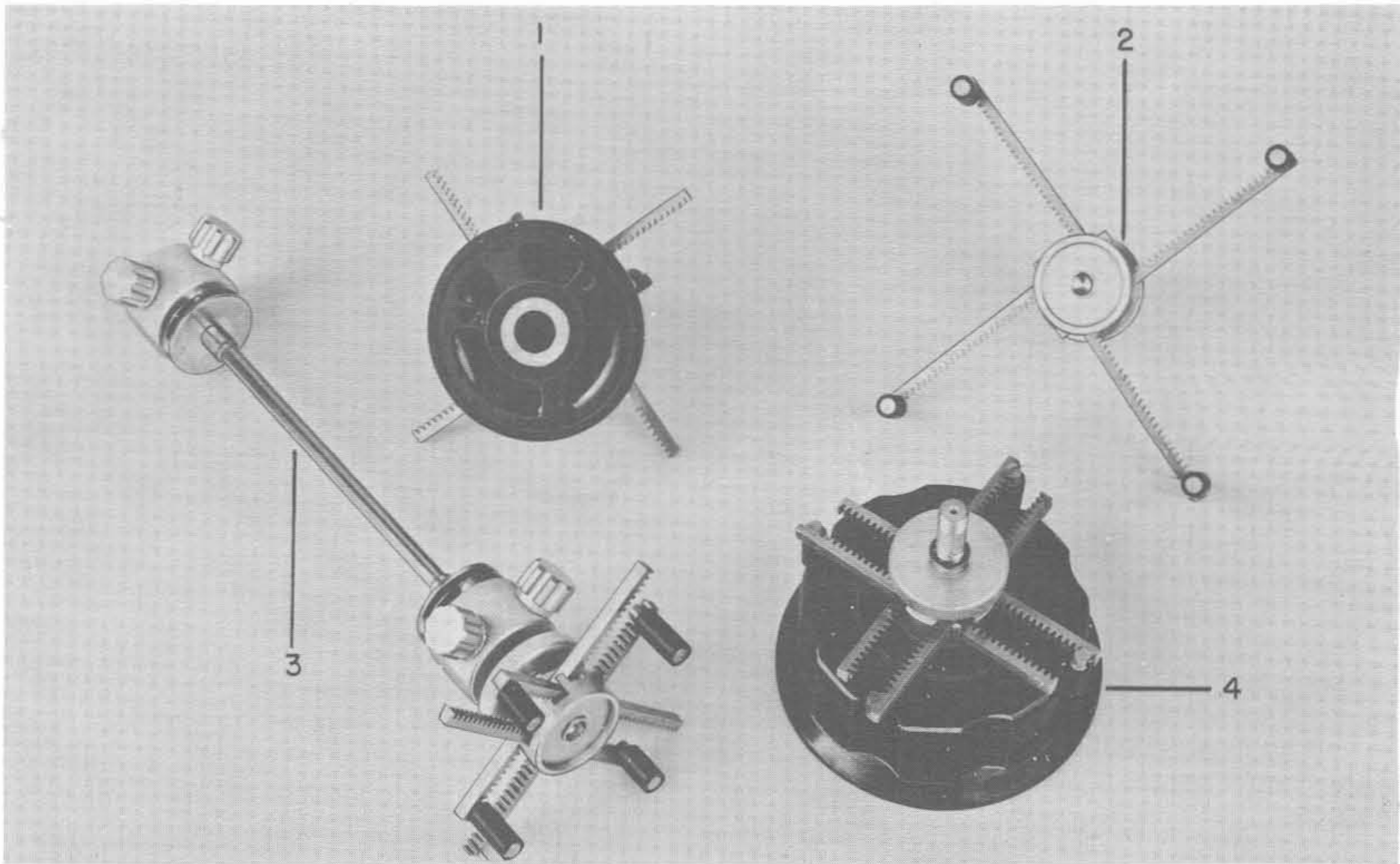

- |   |   |
|---|---|
| 1. Attachment to small knob               | 3. Flexible shaft and universal clutch assembly |
| 2. Universal clutch, spider arms extended | 4. Attachment to large knob                     |

Figure 7. Coupling Attachments.

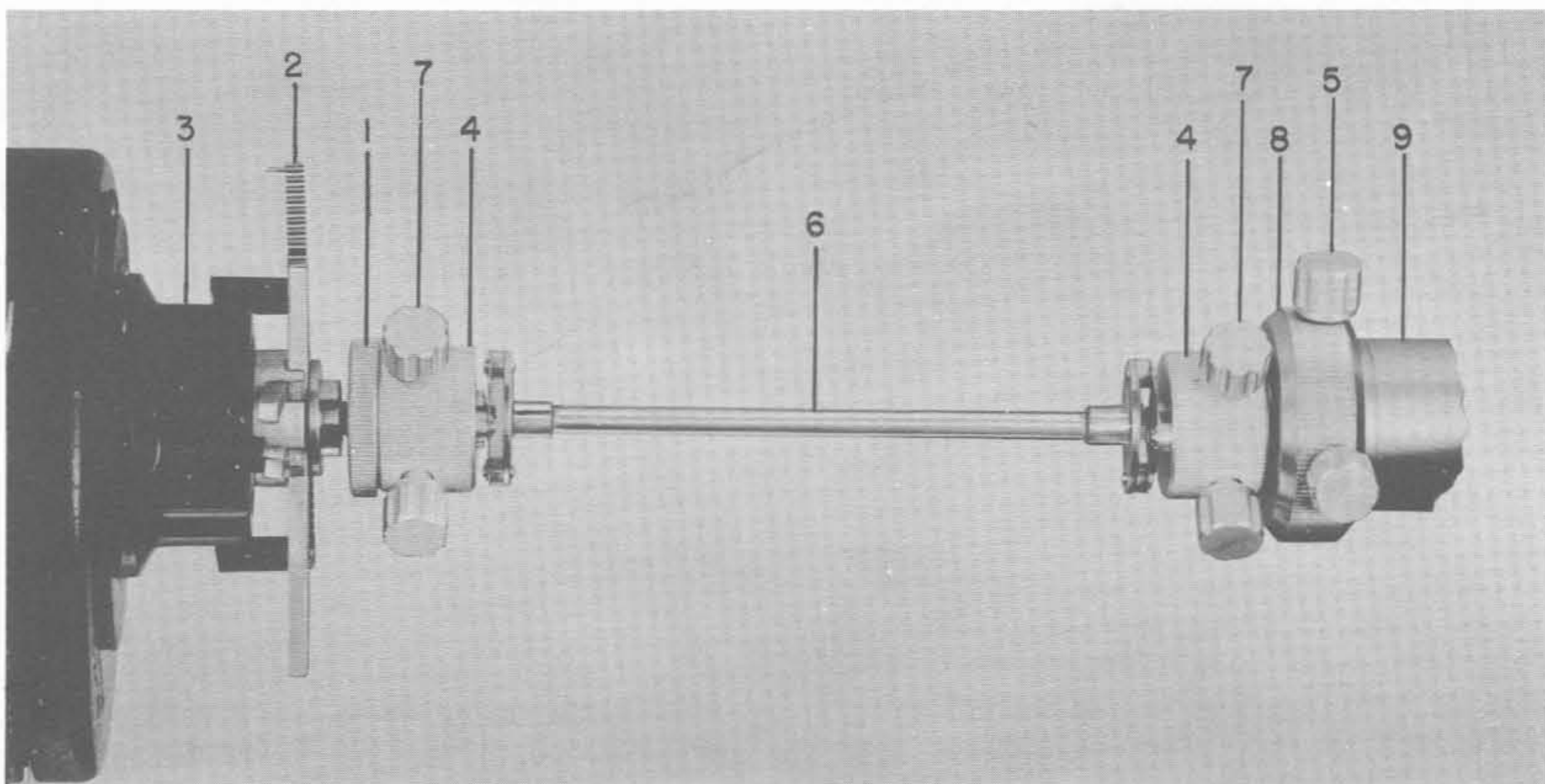

- |                 |                            |                         |
|-----------------|----------------------------|-------------------------|
| 1. Knurled disk | 4. Coupling collar         | 7. Shaft holding screws |
| 2. Spider arms  | 5. Limit switch set screws | 8. Limit switch collar  |
| 3. Driven knob  | 6. Flexible shaft          | 9. Limit switch housing |

Figure 8. Coupling Assembly.

## TYPE 1750-A SWEEP DRIVE

components. A thorough understanding of the action of the Sweep Drive will help prevent trouble.

### 2.2 COUPLING SWEEP DRIVE TO DRIVEN INSTRUMENT.

**2.2.1 GENERAL.** Shafts of 1/4 or 3/8 in. diameter can be coupled directly to the Sweep Drive by means of the flexible shaft provided. Knobs and dials from one to four inches in diameter are coupled by the universal clutch provided, which in turn is attached to the flexible shaft. Before making a direct coupling to a 3/8 in. shaft, remove the insert from one end of the flexible shaft.

#### 2.2.2 ATTACHING UNIVERSAL CLUTCH. (See Figures 7 and 8.)

a. Loosen the knurled disk (1, Fig. 8) on the clutch, and pull out the four spider arms to the position shown in 2, Fig. 7.

b. Place the clutch over the knob or dial (3, Fig. 8) and push in the spider arms until they firmly grab the knob (4, Fig. 7). Keeping pressure on two opposite spider arms with one hand, tighten the knurled disk (1, Fig. 8) with the other. An alternate method is to hold the knob or dial with one hand, and turn the coupling collar (4, Fig. 8) and knurled disk with the other.

#### 2.2.3 SHAFT HEIGHT ADJUSTMENT.

a. Loosen the two wing nuts (9, Fig. 4) that clamp the rotating housing (6).

b. Rotate the housing until the Sweep Drive output shaft is at the same height above the bench as the shaft or knob of the instrument to be driven. The limit switch setting may prevent the housing from turning freely. If the housing does not go up, turn the POSITION control clockwise. If it does not go down, loosen the two set screws (5, Fig. 8) on the large knurled limit switch collar (8).

c. Secure the housing by tightening the two wing nuts (9, Fig. 4).

#### 2.2.4 LINING UP.

a. Attach one end of the flexible shaft (6, Fig. 8) to the Sweep Drive, the other end to the driven shaft. (The "driven shaft" might be the end of a shaft from which the knob is removed or the stub of the universal clutch.)

b. Line up the two shaft ends as well as possible to prevent unnecessary strain in the spring disks of the flexible shaft.

c. Turn the POSITION control and check alignment of the flexible shaft as it turns. Also check that the universal clutch remains securely attached to the driven shaft.

### 2.3 LIMIT SWITCH ADJUSTMENT.

**2.3.1 GENERAL.** In this section, the terms "clockwise" and "counterclockwise" apply as viewed from the front of the Sweep Drive. (Sweep frequency and sweep arc increase with clockwise rotation of the controls.) Markings to indicate limit switch settings are not provided since the switch operates over more than one turn.

**2.3.2 COUNTERCLOCKWISE LIMIT.** The counterclockwise limit of the driving shaft is fixed. To set the counterclockwise limit in the driven shaft:

a. Loosen the pair of holding screws (7, Fig. 8) on the drive end of the flexible shaft, and the two set screws (5) on the limit switch collar (8).

b. Set the limit switch housing (9) to its counterclockwise position. (The housing can be rotated very slightly through three positions, noted by clicks.)

c. Turn the POSITION control to its counterclockwise limit.

d. Turn the driven shaft to the counterclockwise limit desired.

e. Tighten the holding screws (7, Fig. 8) on the flexible shaft.

**2.3.3 CLOCKWISE LIMIT.** The clockwise limit of the driving shaft is adjustable, within a maximum of nine turns.

a. Turn the driven shaft, by means of the POSITION control, to the desired clockwise limit.

b. Rotate the limit switch housing (9, Fig. 8) to its clockwise position. (The housing can be rotated very slightly through three positions, noted by clicks.)

c. Turn the knurled limit switch collar (8) counterclockwise as far as it will go, and tighten the two set screws (5) on the collar.

**2.3.4 SETTING OF LIMIT SWITCH.** The Sweep Drive motor will operate only when the limit switch housing is in its middle position. Therefore, when limits have been set, rotate the housing (9, Fig. 8) to its middle position.

In Figure 2, the limit switch housing (marked "Actuator for Limit Switch") is in the middle position, where it permits the actuator button of a microswitch to project. During normal operation, the arm stays in this position. If a preset limit is reached, the arm is pushed into one or the other of the extreme positions, the actuator button is depressed, and the motor stops.

If, during the operation of the Sweep Drive, the SWEEP ARC or the POSITION control is inadvertent-

ly set to call for movement of the driven shaft beyond its preset limits, the limit switch will stop the motor. To restart the motor, readjust controls to move the driven shaft away from its limit and set the limit switch to its center position by turning the housing (9, Fig. 8) one click.

**2.4 CENTER-OF-SWEEP ADJUSTMENT.** The center of sweep does not vary appreciably as the sweep arc is changed. To set center of sweep, turn SWEEP ARC control to minimum and set to desired position with POSITION control.

## 2.5 CONNECTIONS.

- a. Connect power plug to 115-volt, 50- or 60-cycle supply.
- b. Connect CRO DEFLECTION cable to horizontal deflection plates of the oscilloscope.
- c. Connect BLANKING cable. Ordinarily some network will be required to connect the BLANKING cable to an oscillator, a power supply, or the vertical deflection plates of an oscilloscope. If the Type 1263 Amplitude - Regulating Power Supply is used, connect to the BLANKING terminals of the Power Supply.

## Section 3

### OPERATING PROCEDURE

#### 3.1 START-UP PROCEDURE.

- a. Check flexible shaft coupling assembly for alignment and secureness.
- b. Set SWEEP FREQUENCY and SWEEP ARC controls to minimum. Set POSITION control to desired center of sweep.
- c. Throw POWER switch on. Pilot lamp should light.
- d. Increase speed and arc gradually, and check that the universal clutch holds the knob or dial firmly. Do not use excessive speed.
- e. If the POSITION control moves, reduce speed or arc. Do not hold this control back by hand to stop slipping.
- f. Carefully turn the POSITION control so that the limit switch stops the motor. If cut-out points are not correct, reset the limits in accordance with section 2.3.

#### 3.2 DURING OPERATION.

- a. Do not let the Sweep Drive run unattended for any length of time.
- b. Be alert for sudden changes in sound, which might indicate increased friction or loosening of a part.
- c. If limits of travel are approached gradually, a setting may be obtained where the limit switch just opens, but does not stop the motor in time to prevent an immediate reclosing. The switch may then open and close at each successive cycle, and cause a fuse to burn out due to repeated high motor-starting current. Do not operate the Sweep Drive so close to the preset limits that the switch operates at each cycle.

- d. If fuses burn out, replace with 1-amp Slo-Block fuses only.
- e. Keep all moving parts well lubricated, in accordance with paragraph 4.2. Also make sure that the driven instrument is properly lubricated.

**3.3 BLANKING CIRCUIT.** A shorting contact, closed during clockwise rotation of the driven shaft, is connected to the BLANKING cable. No part of the blanking circuit is grounded. The black lead connects to the cable shield.

When the BLANKING cable is connected to the BLANKING terminals of the Type 1263 Amplitude-Regulating Power Supply, plate voltage is zero during clockwise rotation of the driven shaft, and a zero reference line is traced on the oscilloscope during the return trace.

When the BLANKING cable is connected to the vertical deflection terminals of the oscilloscope, the return trace does not necessarily represent a zero reference line.

**3.4 DEFLECTION VOLTAGE.** A periodically varying voltage of about 2.5 volts peak to peak is provided at the end of the DEFLECTION cable for horizontal deflection of the oscilloscope. No part of the deflection circuit is grounded. The light-colored lead connects to the center of the cable and is negative with respect to the shield at the beginning of the counterclockwise rotation of the driven shaft.

**3.5 BACKLASH.** With large sweep arcs, the CRO deflection voltage is proportional to shaft rotation,

and the calibration of the driven instrument is duplicated closely on the oscilloscope. As the sweep arc is diminished, backlash in the driving mechanism becomes noticeable. The driven instrument stands still for a short time at the beginning of each stroke until play in the bearings and joints has been taken up, and the ordinates of the oscilloscope pattern do not change. This backlash does not ordinarily change much with sweep arc setting, but becomes more noticeable at small arcs, where it may be as much as 30 or 40 percent of the total sweep.

**3.6 CALIBRATION TRANSFER.** To transfer the calibration of a driven instrument to an oscilloscope screen, turn power on and set the SWEEP FREQUENCY control to minimum. Set the driven instrument to the desired calibration points by manually turning the MOTOR SHAFT, and mark the ordinates at which the spots appear on the screen. To eliminate effects of backlash, do not reverse rotation of motor shaft. Mark only with output shaft turning in the counterclockwise direction.

## Section 4

### SERVICE AND MAINTENANCE

**4.1 GENERAL.** The two-year warranty given with every General Radio instrument attests the quality of materials and workmanship in our products. When difficulties do occur, our service engineers will assist in any way possible.

In case of difficulties that cannot be eliminated by the use of these service instructions, please write or phone our Service Department, giving full information of the trouble and of steps taken to remedy it. Be sure to mention the serial and type numbers of the instrument.

Before returning an instrument to General Radio for service, please write to our Service Department or nearest district office (see back cover), requesting a Returned Material Tag. For instruments not covered by the warranty, a purchase order should be forwarded to avoid unnecessary delay.

**4.2 LUBRICATION.** See Table 1, page 10, for recommended lubrication of Sweep Drive.

**4.3 DRIVE BELTS.** Clean the entire casting about every 100 hours of operation and remove any loose rubber particles that have been abraded.

If belts become worn, replace with new Gilmer Belt No. 8862, obtainable from General Radio Company. To replace a belt, follow the procedure below:

- a. Remove front panel.
- b. Remove clamp rings on deflection rheostat connecting rod (1, Fig. 3).

- c. Remove small back cover.
- d. Remove nut (13, Fig. 4) that holds shaft of idler pulley in back.
- e. Pull idler pulley shaft (5, Fig. 3) out at front.

To restore idler pulley, insert spring washer in back of pulley. Adjust belt tension before securing pulley shaft.

**4.4 DEFLECTION RHEOSTAT.** Terminals 1 and 2 (Fig. 10) are provided on the deflection rheostat between the clockwise and counterclockwise ends of the winding, on the circumference of the rheostat housing. The wiper terminal, connected to the center of the deflection cable, is located on the front of the housing. Since the crank of the rheostat travels over an arc of about 90 degrees, only one third of the rheostat winding is in use at a time. The third that is first in use is established during assembly as the section between terminal 1 and the clockwise end, the blue-yellow lead connecting to terminal 1 and the blue-red lead to the clockwise end. If this section becomes worn or opened, the section between terminals 1 and 2, and finally the section between terminal 2 and the counterclockwise end can be substituted as follows: Shift the blue-yellow and blue-red leads in a counterclockwise direction. The lead connecting to the deflection cable remains unchanged, but the deflection rheostat shaft must be turned counterclockwise with respect to the crank when the leads are shifted. Loosen the two set screws in the crank,

GENERAL RADIO COMPANY

turn the shaft counterclockwise about 120 degrees, and tighten the set screws. Start the motor slowly and observe the varying deflection voltage with a voltmeter or on an oscilloscope, and readjust the

shaft if required.

To replace the deflection rheostat, remove screws in the rheostat mounting plate.

TABLE 1. LUBRICATION CHART

Component	Access	Lubrication	Interval (operating time)
Slide Rack (3, Fig. 4)	Remove two screws that attach rear cover.	Wipe off old lubricant. Apply heavy lubricant. (Lubrico MD-T-419, Master Lubricant Co., Philadelphia, is recommended.)	100 hr
Differential (See Fig. 5)	Remove hex nut in center and two wing nuts (9, Fig. 4) at circumference of housing at right rear. Set limit switch housing (7) in center position, remove housing, spring washers, and large gear in front of differential.	Same as for slide rack.	100 hr
Deflection Rheostat (3, Fig. 3)	Remove front cover panel.	One drop of light oil on front bearing.	100 hr
Limit Switch	Remove retaining ring and knurled collar at end of output shaft (5, Fig. 4).	Apply Lubrico with narrow stick or wire.	500 hr
Limit Switch Actuator Arm	Remove hex nut in center of housing at right rear.	Same as for limit switch.	500 hr
Blanking Cam (11, Fig. 4)	Loosen four screws that clamp U-shaped and L-shaped housings to rear of casting and remove U-shaped part.	Clean and apply a small amount of Lubrico.	100 hr
Motor	Motor ball bearings are sealed to protect against dirt and foreign matter and to prevent loss of grease. Ball bearings should require no attention for several years of normal service.		

## Section 5 PARTS LIST

		GR No.
R1	RESISTOR, Fixed, composition, 3.3 k $\pm$ 10%, 1/2 w	REC-20BF
R2	RESISTOR, Fixed, composition, 3.3 k $\pm$ 10%, 1/2 w	REC-20BF
R3	RESISTOR, Fixed, composition, 5.6 k $\pm$ 10%, 1/2 w	REC-20BF
R4	RESISTOR, Fixed, composition, 5.6 k $\pm$ 10%, 1/2 w	REC-20BF
R5	RESISTOR, Variable, 20 k $\pm$ 5%, 5 w (Res between taps 6.7 k)	973-401
R6	RESISTOR, Fixed, wire-wound, 24 $\Omega$ $\pm$ 5%, 2 w	REW-6C
C1	CAPACITOR, Electrolytic, 60 $\mu$ f, 25 dcwv	COE-47
C2	CAPACITOR, Electrolytic, 60 $\mu$ f, 25 dcwv	COE-47
C3	CAPACITOR, Electrolytic, 100 $\mu$ f, 15 dcwv	COE-46
C4	CAPACITOR, Electrolytic, 100 $\mu$ f, 15 dcwv	COE-46
D1	Crystal Diode	1N51
D2	Crystal Diode	1N51
F1	Fuse, 1 amp, Slo-Blo 3AG	FUF-1
F2	Fuse, 1 amp, Slo-Blo 3AG	FUF-1
MO1	Motor	1750-43
P1	Pilot Light, 6.3 v, Mazda Type 44	2LAP-939
PL1	Input Plug	CAP-19
PL2	Plug	1750-21
PL3	Plug	1750-22
RX1	Rectifier	2RE-24
RX2	Rectifier	2RE-6
RX3	Rectifier	2RE-6
S1	Switch, dpst	SWT-333, NP
S2	Switch	Built in
S3	Switch (Microswitch No. BA-2ST)	1750-40
T1	Variac <sup>®</sup> Autotransformer	W2-401

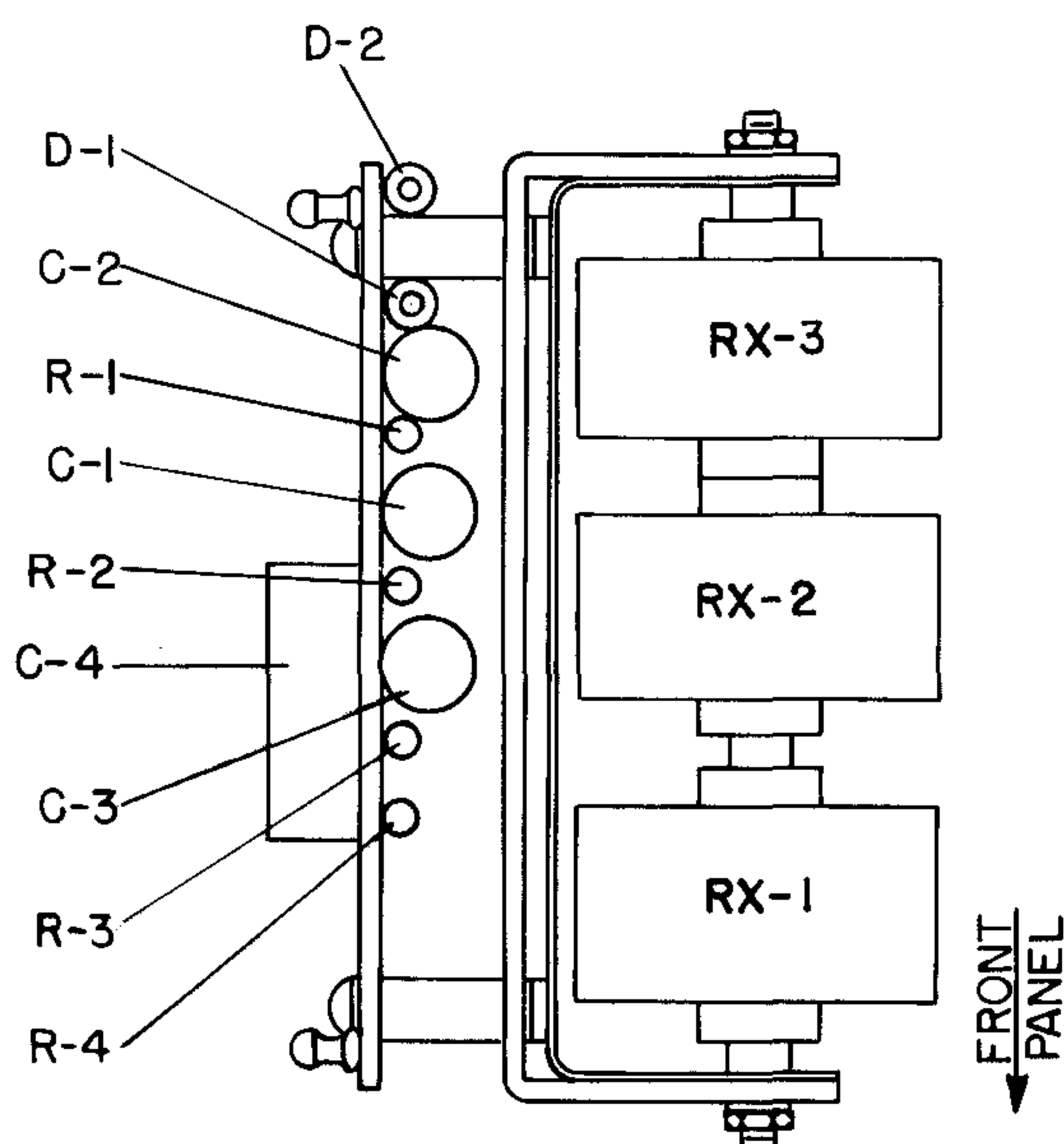

LOCATION OF OTHER COMPONENTS:

- R-5 SEE 3, FIG. 3
- R-6 AT LIMIT SWITCH
- F-1,-2 LEFT SIDE
- MO-1 SEE 1, FIG. 4
- P-1 LEFT SIDE
- PL-1 LEFT SIDE (POWER)
- PL-2 LEFT SIDE (CRO DEFLECTION)
- PL-3 LEFT SIDE (BLANKING)
- S-1 LEFT SIDE (POWER)
- S-2 AT 11, FIG. 4
- S-3 AT 7, FIG. 4
- T-1 SEE 12, FIG. 4

Figure 9. Electrical Components.



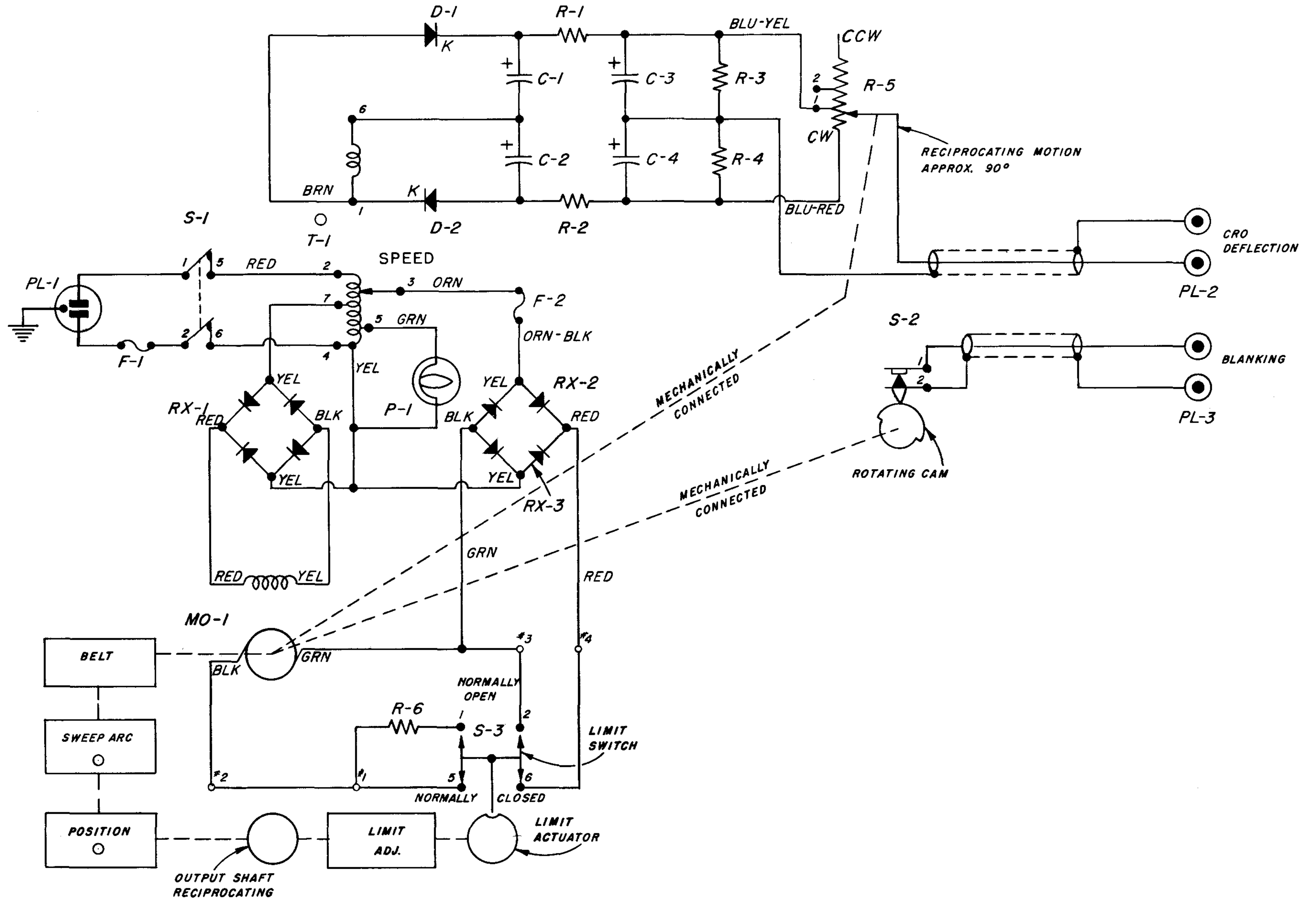

Figure 10. Schematic Wiring Diagram.

# GENERAL RADIO COMPANY

WEST CONCORD, MASSACHUSETTS

EMerson 9-4400

Mission 6-7400

## DISTRICT OFFICES

### NEW YORK

Broad Ave. at Linden, Ridgefield, N. J.  
Telephone N.Y. WOrth 4-2722  
N.J. WHitney 3-3140

### PHILADELPHIA

1150 York Rd., Abington, Penna.  
Telephone TURner 7-8486  
Phila., HAncock 4-7419

### WASHINGTON

8055 13th St., Silver Spring, Md.  
Telephone JUniper 5-1088

### CHICAGO

6605 West North Ave., Oak Park, Ill.  
Telephone Village 8-9400

### LOS ANGELES

1000 N. Seward St., Los Angeles 38, Calif.  
Telephone HOLlywood 9-6201

### SAN FRANCISCO

1186 Los Altos Ave., Los Altos, Calif.  
Telephone WHitecliff 8-8233

### CANADA

99 Floral Pkwy., Toronto 15, Ont.  
Telephone CHerry 6-2171

## REPAIR SERVICES

### EAST COAST

General Radio Company  
Service Department  
22 Baker Ave., W. Concord, Mass.  
Telephone EMerson 9-4400

### NEW YORK

General Radio Company  
Service Department  
Broad Ave. at Linden, Ridgefield, N. J.  
Telephone N.Y. WOrth 4-2722  
N.J. WHitney 3-3140

### MIDWEST

General Radio Company  
Service Department  
6605 West North Ave., Oak Park, Ill.  
Telephone Village 8-9400

### WEST COAST

General Radio Company  
Service Department  
1000 N. Seward St.  
Los Angeles 38, Calif.  
Telephone HOLlywood 9-6201

### CANADA

Bayly Engineering, Ltd.  
First Street, Ajax, Ontario  
Telephone Toronto EMpire 2-3741

(Representatives in Principal Overseas Countries)

