

**OPERATING INSTRUCTIONS
FOR
TYPE 707-A
CATHODE-RAY
NULL DETECTOR**

Form 524-C



**GENERAL RADIO COMPANY
CAMBRIDGE, MASSACHUSETTS**



PATENT NOTICE

This instrument is manufactured under the following U. S. Patents and license agreements:

Patents of the American Telephone and Telegraph Company, solely for utilization in research, investigation, measurement, testing, instruction, and development work in pure and applied science.

Patent 2,173,427



Panel view of Type 707-A Cathode Ray Null Detector

GENERAL RADIO COMPANY

OPERATING INSTRUCTIONS FOR TYPE 707-A CATHODE-RAY NULL DETECTOR

1.0 DESCRIPTION

1.1 Purpose

The Type 707-A Cathode-Ray Null Detector is a sensitive and highly selective null detector of the visual type for use in balancing an impedance bridge. It indicates, separately, the effect of adjusting the reactive and resistive balancing controls of the bridge. It also indicates whether one of these controls, selected as desired, is off-balance in a positive or a negative direction. It employs a tuned degenerative amplifier which is entirely free from any electromagnetic or electrostatic pickup; the instrument does not in itself broadcast any appreciable electromagnetic field.

1.2 Range and Selectivity

The instrument can be used with bridges operating at any frequency between 25 cycles and 20 kilocycles. The ampli-

fier has an input impedance of one megohm, a gain of 80 decibels, and a selectivity against the second harmonic of 40 decibels. The instrument has an observable sensitivity of about 100 microvolts at 60 cycles and 200-300 microvolts at 1000 cycles.

1.3 Power Supply

The instrument operates from a 100-115 volt single phase a-c line at any commercial frequency between 40 and 60 cycles. It consumes about 20 watts at 60 cycles.

1.4 Auxiliary Equipment

All necessary tubes are supplied with the instrument together with a power cord and a shielded cord (Type 274-NE) for connection to the detector terminals of the bridge. Tuning and phasing units are not supplied and must be ordered separately.

2.0 INSTALLATION

2.1 Mounting

Ground the cabinet frame (lowest binding post on left-hand side). Rotate the cylindrical visor protruding over the cathode-ray tube to afford optimum shielding from excessive room illumination.

2.2 Tubes

Install tubes in their sockets in accordance with the labels. Be sure that the grid caps are attached.

2.3 Tuning Unit

Insert the proper six-prong tuning unit into the six-hole base along the rear of the cabinet. Only one way of insertion is possible. Make sure that the P number (P-60, P-100, etc.) of this unit corresponds to the frequency of the generator which is to be used to energize the impedance bridge.

2.4 Phase Unit

If this bridge generator frequency is to be 100 cycles or less, insert the four-prong 707-P1 phase unit into the four-socket base along the rear of the cabinet. If the bridge generator frequency is between 100 and 400 cycles, use the 707 P2 phase unit instead. If this frequency is to be any value over 400 cycles, do not insert any unit in this phase socket base.

2.5 Power Supply

Replace the cover of the instrument. Turn the power switch (under pilot light) to the OFF position. Attach the power socket on the rear of the instrument to a 100-115 volt a-c line (40-60 cycles).

2.6 Preliminary Adjustments

The following procedure should be followed in the order noted:

GENERAL RADIO COMPANY

(1) Turn the BRILLIANCE control knob to the extreme left, snapping off a switch controlled by this knob.

(2) Set the FOCUS control knob to the extreme right and the GAIN control knob to the extreme left.

(3) Set the SWEEP AMPLITUDE knob at mid-scale position.

(4) Set the SWEEP FREQUENCY switch on the LINE side.

(5) Turn on the power switch (lighting the pilot light).

(6) Wait for about fifteen seconds and then turn the BRILLIANCE control knob to the extreme right. This should produce a blurred area of illumination on the cathode-ray tube screen. Note: This BRILLIANCE control knob must be turned to the extreme left each time before the power is turned on, else the tube may fail to focus. No permanent harm, however, is done.

(7) Adjust the FOCUS and BRILLIANCE control knobs until a sharp, fine line of sufficient intensity is obtained on the screen of the cathode-ray tube. Right-hand rotation of the BRILLIANCE control knob increases the intensity while the proper position of the FOCUS knob must be determined by trial. A line of reduced brilliance can be focused more sharply and will afford, ultimately, a greater sensitivity. This line gives the "sweep" deflection of the CRO spot, the amplitude of which may be controlled by a suitable adjustment of the SWEEP control knob. Ordinarily a sweep amplitude of from 1/2 inch to 3/4 inch is preferable. If at any time the central area of the cathode-ray screen goes black, due to failure of tube focus, turn off the BRILLIANCE control knob, wait a few seconds, and repeat these focusing operations.

(8) If the sweep line is not exactly horizontal, that is, parallel to the longer dimension of the panel, TURN OFF THE POWER SWITCH, remove the cover, and twist the cathode-ray tube, together with its friction socket, in the proper direction until exact horizontal alignment is obtained. CAUTION: The metallic housing of the cathode-ray tube is at a potential of several hundred volts above the cabinet when the power switch is on.

(9) If the impedance bridge is to be energized by the same power line and hence at the same frequency as the power source for the null detector, leave the SWEEP FREQUENCY switch in the LINE position. If not, shift it to the EXTERNAL position and connect the EXTERNAL terminals beside it directly to the terminals of the generator which is to energize the bridge. The polarity of this connection is immaterial since neither of these terminals is grounded at the null detector end. It is

permissible, if desired, to have either of these generator terminals grounded.

(10) Connect the detector terminals of the bridge to the INPUT terminals of the null detector. Use the shielded cord supplied for this purpose (Type 274-NE). The bridge terminal which is, or which may be, grounded permanently should be connected to the lower of the two INPUT terminals, thereby actually grounding it. If one detector terminal of the bridge is already grounded independently, it will be unnecessary to duplicate the ground at the null detector. If the bridge circuits are such that it is impossible to ground directly one of the detector terminals, then a suitable shielded transformer, such as the Type 578 should be interposed between the bridge terminals and the input terminals of the null detector, thereby permitting the chassis of the latter to be grounded directly.

(11) Set the GAIN control at mid-scale and the SELECTIVITY control to the extreme left (giving maximum selectivity). Turn the SWEEP AMPLITUDE control to the minimum position (extreme left) to eliminate the sweep deflection and energize the bridge. Unless the bridge is perfectly balanced, this should give a vertical line on the cathode-ray screen. Manipulate the GAIN control to make this line about 1/4 inch long.

(12) Adjust the TUNING control knob to tune the amplifier to the exact frequency of the bridge generator. This occurs when the vertical line has its maximum length. Note: In making this adjustment the maximum length should not exceed 1/4 inch. Control this if necessary by a readjustment of the GAIN control knob. The range of the TUNING control knob permits a frequency adjustment of $\pm 5\%$ of the nominal value (center scale, approximately). This should permit the amplifier to be tuned exactly to the generator frequency if the latter lies within this range. Once this tuning adjustment has been made, it will not have to be changed provided that the bridge generator retains its initial frequency.

2.7 Phase Adjustment

One of the advantages of this null detector is its ability to indicate, separately, the effect of adjusting the resistive and reactive controls used in balancing the impedance bridge. To accomplish this, the phase difference between the sweeping voltage and the bridge generator voltage must be adjusted to a definite proper value by manipulating the PHASE control knob. An elliptical pattern is produced because both the horizontal

GENERAL RADIO COMPANY

sweeping voltage (from the bridge generator) and the vertical deflecting voltage (due to a lack of bridge balance) are essentially sinusoidal in character and of the same frequency. At the user's option, either the resistive or the reactive bridge balance control may be made to tilt the elliptical pattern observed on the cathode-ray tube screen while the other control, reactive or resistive, will close the ellipse into a straight line without tilting it.

The detector sensitivity of both the tilting and the closing effect is essentially the same so that there is no pronounced choice between them on that score. Which choice is made will be determined largely by the type of measurements contemplated. It should be noted, however, that an indication is afforded whether the bridge control selected to tilt the ellipse is off-balance in a positive or in a negative direction by noting whether the ellipse is tilted up to-the-right or down-to-the-right, or vice versa. No such distinction is given for the other bridge control which closes the ellipse.

To make the initial phase adjustment, proceed as follows:

(1) Set the SWEEP AMPLITUDE control to eliminate the horizontal sweep motion (extreme left).

(2) Set the GAIN control to give a straight line vertical deflection of about 3/8 inch.

(3) Proceed to balance the bridge in the normal manner by alternately adjusting its resistive and reactive controls until all vertical deflection is eliminated (giving a small spot on the screen) with the GAIN control turned to the extreme right (maximum gain). Note: Turn SWEEP AMPLITUDE control to obtain a horizontal line on the screen.

(4) Assuming that the reactive bridge control has been chosen to tilt the ellipse and that the bridge has been balanced exactly as in (3), displace the reactive bridge control slightly. In gen-

eral, a tilted ellipse will result. Now adjust the PHASE control knob until this ellipse closes into a straight line inclined to the horizontal. Next, restore the reactive bridge control to the balance position, which should tilt this straight line into a horizontal position. Then displace this reactive bridge control the same amount in the opposite direction. This should again tilt the straight line but in the opposite direction.

(5) Make what minor adjustment of the PHASE control may be necessary until a displacement of the reactive bridge control tilts the straight line up to an angle of not over 30 degrees with a horizontal in either direction without showing any tendency for this line to open up into an ellipse. Do not be concerned if an increased vertical deflection does tend to open up this line somewhat. Note: In making the adjustment described in (4) and (5), the resistive bridge control must be in a position corresponding to exact bridge balance as attained in (3); otherwise, confusion will result.

(6) When the proper phase adjustment has been attained, it will be found that, with the straight line horizontal or inclined, a displacement of the resistive bridge control will merely open up the ellipse, leaving its major axis unchanged.

(7) Obviously, the above procedures may be reversed if it is desired to have the resistive bridge control function to tilt the ellipse.

(8) When once this phase adjustment has been made, it will ordinarily not have to be changed when variations or substitutions are made and the unknown impedance measured to the same bridge.

(9) The TUNING control is quite independent of all other controls, but it will be found that any change in the TUNING control or the SELECTIVITY control adjustment will produce a phase displacement in the amplifier and require a readjustment of the PHASE control.

3.0 OPERATION

3.1 Using the Null Detector in Bridge Balancing.

When the foregoing adjustments have been made the null detector is ready for use. Ordinarily, the instrument is used in the condition of maximum selectivity which is attained by turning the SELECTIVITY knob to the extreme left. When working with a bridge energized at commercial frequencies, however, a noticeable re-

sponse lag will be observed every time the detector input voltage is changed. This lag, which is the natural result of the high selectivity of the amplifier, is in general not objectionable. Such a response lag may, however, be reduced by diminishing the selectivity (turning the SELECTIVITY knob to the right), provided that sufficient selectivity remains to prevent any harmonics in the detector input from distorting the ellipse too badly. In



GENERAL RADIO COMPANY

frequencies higher than commercial values, say, above 100 cycles, this response lag is not noticeable even with full selectivity and the SELECTIVITY control should be kept at the extreme left.*

One of the advantages of this device is that it cannot be injured by applying excessive voltage to the input terminals. This permits the instrument to be used ordinarily with maximum gain (sensitivity) at all times, thus eliminating the need of advancing the sensitivity by stages each time the bridge is progressively balanced. With the amplifier wide open and with the bridge considerably off-balance, a distorted elliptical pattern due to overloading the amplifier, will be seen on the screen. Then, as that bridge control which is selected to adjust the tilt of the ellipse is made to pass through its balance position, a sudden and easily detected shift will occur in the distorted pattern. Thereafter, an adjustment of the other bridge control will directly produce a workable ellipse. If desired, it is, of course, permissible to reduce the GAIN control of the amplifier and obtain a workable ellipse even with the bridge considerably off-balance.

With a little practice, one or two adjustments of each bridge control will serve to balance it completely, thereby reducing the ellipse to an exactly horizontal straight line. This separation of the observed effects of changing the two bridge controls is especially helpful in balancing those types of bridges which have a sliding zero, that is, whose minimum for either control is a function of the setting of the other control. It is also useful in measuring non-linear impedances, such as iron core inductors, whose impedance components are functions of the applied voltage and hence may vary as the balancing controls of the bridge are varied.

If desired, a precise setting of one control may be made with only a moderately accurate setting of the other control. For example, the ellipse may be made accurately horizontal without bothering to close it completely, or the ellipse may be closed exactly while still tilted somewhat. This permits the accurate measurement of one component of the unknown impedance which is steady, while the other component may be varying with time. It also shows, uniquely, which of these impedance components may be varying with time or with, say, the voltage applied to the bridge.

*Otherwise the amplifier may have a tendency to go into oscillation.

Obviously, with the bridge controls set permanently to correspond to certain nominal component values of the unknown impedance and with the GAIN control adjusted appropriately, the degree of ellipse tilt and the degree of ellipse opening obtained with any specimen impedance may be calibrated to indicate tolerance limits for approximately equal impedances. Furthermore, the departure of that component of the impedance which tilts the ellipse may be seen at once as a positive or a negative departure. No harm is done to the detector while successive sample impedances are being substituted in the bridge network. These features, together with the instantaneous response, make this null detector extremely useful in rapid production acceptance tests.

Because of its practically instantaneous response and recovery, in common with all other electronic types of null detectors, spurious transient voltages may be disregarded almost unconsciously. This minimizes the annoyance and loss of time encountered in using null detectors employing a sluggish meter or galvanometer as the visual indicating instrument. Under certain conditions of overload a perceptible fluttering of the distorted elliptical pattern may be observed. This need cause no concern, however, since it always vanishes when the input level is reduced in approaching balance.

3.2 Further Comments on Use

The phase network plug-in units, 707-P1 or 707-P2, merely serve to increase the capacitance elements of this network so as to insure a wider range of phase adjustment at the lower frequencies. If the bridge is operated from a power line, no difficulty will be encountered using them. If, however, the bridge is energized by a local oscillator, the use of one of these plug-in units will increase the drain on this oscillator and may thereby reduce the voltages available for applying to the bridge. There is no objection to omitting the phase network plug-in unit at any frequency, provided that sufficient range of phase control remains available to permit the adjustment outlined in Section 2.7.

In measuring non-linear impedances, such as iron-core inductors, it may happen that the large selectivity of the amplifier is still insufficient to eliminate the effect of the strong harmonic content in the detector input when the bridge is balanced at the fundamental of the applied frequency. In this case, a cyclic curve, or a horizontal figure 8 pattern, will be obtained instead of a straight line. This will, however, cause no great difficulty

GENERAL RADIO COMPANY

if the bridge is balanced to make this figure have a horizontal major axis and to reduce the curvature or the area of the figure 8 loop to a minimum. If the sensitivity is sufficient, reducing the gain control will straighten out this curvature to a proportionate degree.

It is noticeably easier to detect a ripple superimposed upon a straight line than to determine whether that line is appreciably tilted or opened into an ellipse. Consequently, when extreme sensitivity of the detector is desired and when exciting the bridge at a frequency above 100 cycles, it may be helpful to sweep the cathode-ray spot at the commercial frequency energizing the bridge and adjust the bridge to eliminate all visible ripples of this line. When so doing, of course, the phase separation of the effect of adjusting the bridge controls is lost and these controls must be adjusted alternately to successively decreasing minima. This change of sweeping frequency may be made instantly by throwing the SWEEP FREQUENCY switch. Thus the bridge may be balanced first in the ordinary manner while sweeping at the bridge frequency and separating the effect of the two bridge controls, while the final exact adjustment is made by shifting the sweep to the commercial frequency and eliminating all traces of ripple.

The degenerative amplifier used in the Type 707-A Null Detector does not function normally at frequencies higher than 5000 cycles. However, allowing for a decrease in sensitivity, the instrument is still, in general, a useful null detector at frequencies up to at least 20 kc. When used in this range (5-20 kc) the tuning network plug-in unit should be omitted altogether and the SELECTIVITY control turned to the extreme right-hand position. Selectivity will, of course, be lacking.

3.3 Other Uses of This Instrument

Aside from its use as a null detector in balancing impedance bridges, numerous other applications of this instrument will occur to the user. These embody any use to which a cathode-ray oscillograph preceded by an amplifier may be put.

For example, the spot may be swept at the commercial line frequency or a voltage of any frequency may be applied to the external sweep terminals, while another voltage of a different frequency and for which the amplifier is tuned may be applied to the input terminals. Then, by means of the Lissajous figure obtained and the time rate of its cyclic convolution, these two frequency values may be compared one with the other in the customary manner.

The vertical deflection of the cathode-ray spot, preceded as it is by an amplifier of considerable gain and selectivity, may be calibrated (up to 1/2" total deflection), thus permitting the instrument to be used (without sweep) in measuring peak values of small a-c potentials (hum levels in a-c power supply, etc.) with a high input impedance (1 megohm).

With appropriate tuning of the amplifier, some success may be attained in measuring the harmonic components of a source of a-c voltage.

Two voltages of the same frequency may be adjusted (by external means) to have the same phase by attaching them, separately, to the input terminals and adjusting the sweep circuit, energized at the same frequency, to give a straight line inclined at the same angle in both cases. An empirical calibration of the phase control knob would, of course, permit a measurement, by substitution methods, of the phase difference between two voltages.

CAUTION: In order to prolong tube life and to prevent the spot from burning the screen, it is recommended that the BRILLIANCE control be turned off (extreme counterclockwise position) in the intervals between measurements.

GENERAL RADIO COMPANY

PARTS LIST

Resistors

R-1 = 1 MΩ
 R-2 = 1 MΩ
 R-3 = 1 MΩ
 R-4 = 1 MΩ
 R-5 = 50 kΩ
 R-6 = 40 kΩ
 R-7 = 20 kΩ
 R-8 = 40 kΩ
 R-9 = 50 kΩ
 R-10 = 50 kΩ
 R-11 = 242 kΩ $\pm 1/4\%$
 R-12 = 242 kΩ $\pm 1/4\%$
 R-13 = 121 kΩ $\pm 1/4\%$
 R-14 = BT-1/2
 R-15 = BT-1/2
 R-16 = BT-1/2
 R-17 = 15 kΩ
 R-18 = 0.5 MΩ
 R-19 = 68 kΩ
 R-20 = 0.2 MΩ
 R-21 = 3 MΩ
 R-22 = 0.2 MΩ
 R-23 = 1 MΩ
 R-24 = 1 MΩ
 R-25 = 3 MΩ
 R-26 = 70 kΩ
 R-27 = 20 kΩ
 R-28 = 0.1 MΩ
 R-29 = 0.1 MΩ
 R-30 = 1 MΩ
 R-31 = 10 kΩ
 R-32 = 500 Ω
 R-33 = 10 kΩ
 R-34 = 1 kΩ

} These 3 resistors
 } determined in lab-
 } oratory tests.

Condensers

C-1 = 0.04 μf
 C-2 = 0.04 μf
 C-3 = 0.04 μf
 C-4 = 0.04 μf
 C-5 = 0.05 μf
 C-6 = 0.025 μf
 C-7 = 0.025 μf
 C-8 = } Mounted Phasing
 C-9 = } Units 707-P1 & P2
 C-10 = 4 μf
 C-11 = 4 μf
 C-12 = 1 μf
 C-13 = 1 μf
 C-14 = 1 μf
 C-15 = 1 μf
 C-16 = 505
 C-17 = 505
 C-18 = 505
 C-19 = Dub. 4

} Mounted in
 } assembly
 } 707-35
 } Mounted tuning
 } units 707-P42,
 } P50 and P60,
 } etc.

Tubes

V-1 = RCA Type 6K7G
 V-2 = RCA Type 6F8G
 V-3 = RCA Type 6J5G
 V-4 = RCA Type 913
 V-5 = RCA Type 6X5

Fuses

F-1 = 1/2 amp. } Type 7AG
 F-2 = 1/2 amp. } (or 8AG)



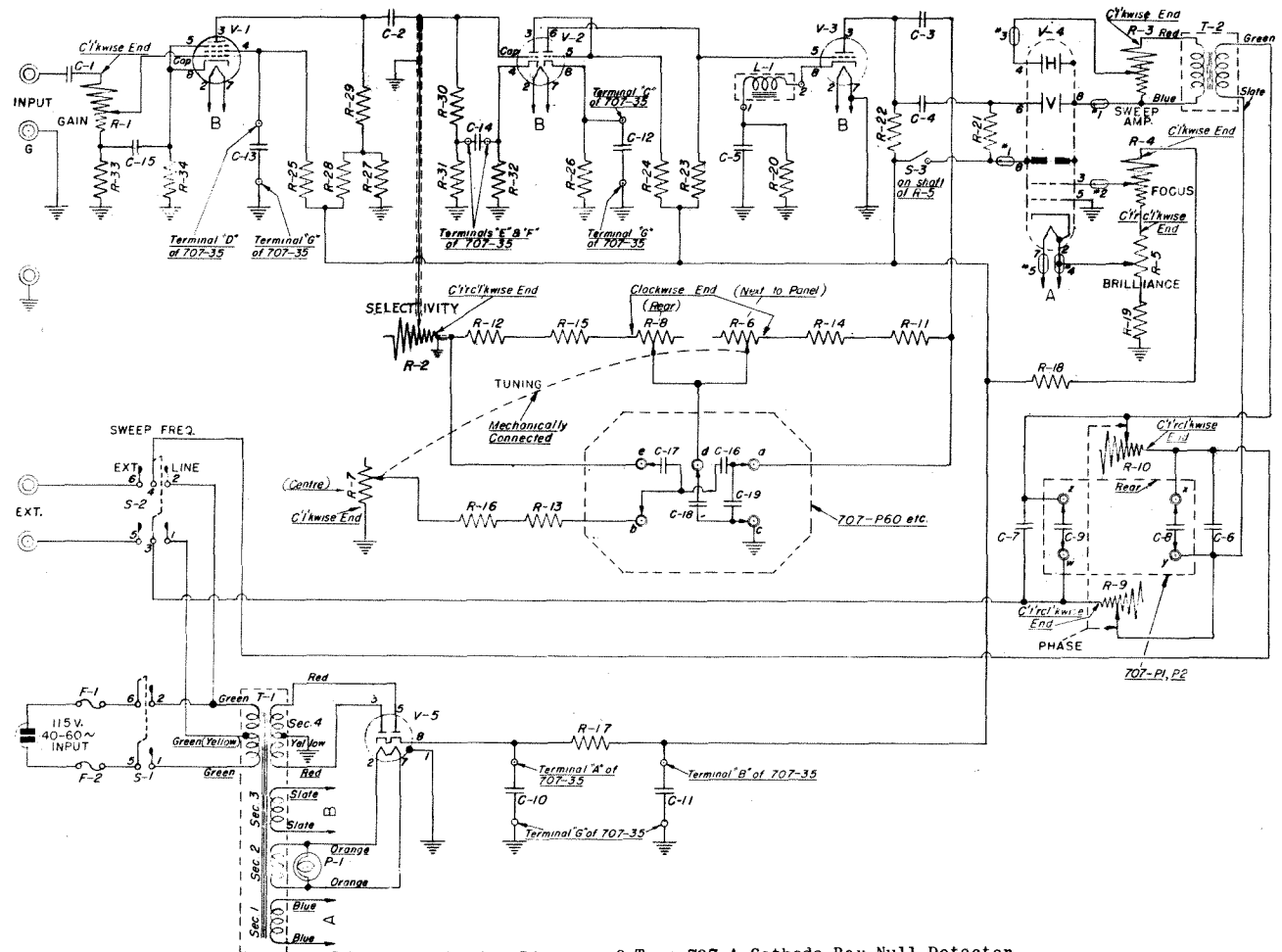

7

FIGURE 1. Wiring Diagram of Type 707-A Cathode Ray Null Detector

GENERAL RADIO COMPANY

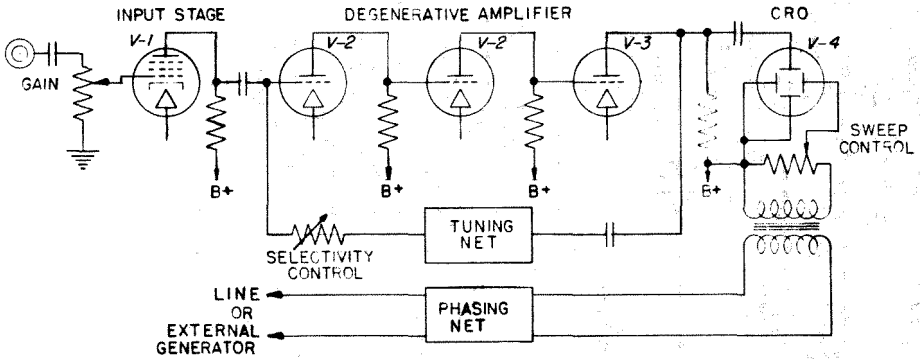

FIGURE 2. Schematic Wiring Diagram

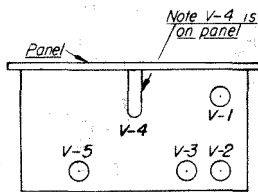

FIGURE 3. Location of Tubes



Gen
1.6
100-21118
1.6
0.016
0.002

