

OPERATING INSTRUCTIONS



TYPE 1617-A

CAPACITANCE BRIDGE

1617-A

GENERAL RADIO COMPANY

A



File Courtesy of GRWiki.org



GenRad

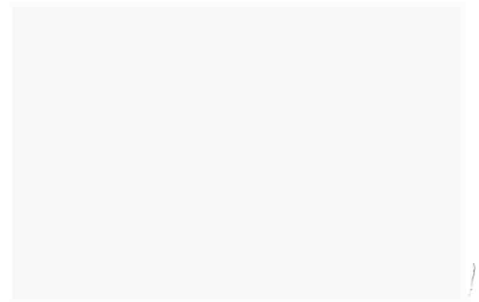

GR 1617 **Capacitance Bridge**

1617-0100-E

Instruction Manual



WARNING

Use of this bridge can involve exposure to potentially dangerous high voltages. For operator safety, no measurements should be attempted until the operator has read, and understands, operating procedures outlined in this manual, pages 1 through 18.

GR 1617

Capacitance Bridge

1617-0100-E

© **GenRad 1976**

Concord, Massachusetts, U.S.A. 01742

Form 1617-0100-E

August 1978

ID-2528



SPECIFICATIONS

Quantity	Frequency	Range	Accuracy
Capacitance	120 Hz internal *	0 to 0.11 F	$\pm 1\% \pm 1 \text{ pF}$, smallest division 2 pF; residual ("zero") capacitance approximately 4 pF
		0.11 F to 1.1 F	$\pm 2\%$
	40 Hz to 120 Hz external (useful down to 20 Hz with reduced accuracy)	0 to 1.1 F	Same as above with suitable generator
	120 Hz to 1000 Hz external	0 to 1 F $\left(\frac{100}{f_{\text{Hz}}}\right)^2$	$\pm 1\% \pm 1 \text{ pF}$ with suitable generator and precautions
Dissipation Factor	120 Hz internal or 40 Hz to 120 Hz	0 to 10 $\frac{f_{\text{Hz}}^*}{120}$	$\pm 0.001 \pm 0.01 \text{ C (in F)} \pm 2\%$
	120 Hz to 1 kHz	0 to 10	$\left(\pm 0.001 \pm 0.01 \text{ C (in F)}\right) \frac{f_{\text{Hz}}}{120} \pm 2\% *$

Lead-Resistance Error (4-terminal connection): Additional capacitance error of less than 1% and *D* error of 0.01 for a resistance of 1Ω in each lead on all but the highest range, or 0.1Ω on the highest range.

Internal Test Signal: 120 Hz (synchronized to line) for 60-Hz model; 100 Hz for 50-Hz model. Selectable amplitude less than 0.2 V, 0.5 V, or 2 V. Phase reversible.

External Test Signal: 20 Hz to 1 kHz with limited range (see above).

Internal DC Bias Voltage and Voltmeter: 0 to 600 V in 6 ranges.

Voltmeter Accuracy: $\pm 3\%$ of full scale.

Internal DC Bias Current: Approximately 15 mA maximum.

Ammeter Range: 0 to 20 mA in 6 ranges. Can detect $\frac{1}{2}\text{-}\mu\text{A}$ leakage.

Ammeter Accuracy: $\pm 3\%$ of full scale.

External Bias: 800 V maximum.

Power Required: 105 V to 125 V or 210 V to 250 V, 60 Hz, 18 W maximum. Models available for 50-Hz operation.

Accessories Supplied: Four-lead and shielded two-lead cable assemblies.

Accessories Required: None for 120-Hz measurements. The Type 1311 Oscillator is recommended for measurement at spot frequencies, the Type 1310 Oscillator for continuous frequency coverage.

Mechanical Data: Flip-Tilt Case.

Model	Width		Height		Depth		Net Wt		Ship Wt	
	in	mm	in	mm	in	mm	lb	kg	lb	kg
Portable	16 $\frac{1}{4}$	415	15	385	9	230	26	12	34†	15.5
Rack	19	485	14	355	6 $\frac{7}{8}$ **	160	28	13	43†	20

*120 Hz is the frequency of the internal signal for the 60-Hz model; it becomes 100 Hz in the 50-Hz model.

**Behind panel.

†Estimated.

Summary of EIA and MIL Specifications on Testing Electrolytic Capacitors

Specification and Capacitor Type	Frequency	AC Level	Accuracy		DC Polarizing Voltage
			C	Loss	
MIL C—3965 C Tantalum Foil and Sintered Slug Capacitors	120 \pm 5 Hz	Less than 30% of DCWV or 1 V, whichever is smaller	2%	R or P.F. 2%	C—Sufficient for no reversal of polarity. D—"Polarized Capacitance Bridge" Sum of ac and dc shall not exceed DCWV.
MIL C—26655-B Solid Tantalum Capacitors	120 \pm 5 Hz	Limited to 1V, rms	2%	D, 10%	C—Max bias 2.2 V. D—"Polarized Bridge", 2.2-V dc max.
RS 228 Tantalum Electrolytic Capacitors	120 Hz	Small enough not to change value	$\pm 2\frac{1}{2}\%$	D, 5%	Optional
MIL C-62 B Polarized Aluminum Capacitors	120 \pm 5 Hz	Limited to 30% of DCWV or 4 V, whichever is smaller	2%	D, 2%	No bias required if ac voltage less than 1 V. However, if bias causes differences, measurements with bias shall govern.
RS 154 B Dry Aluminum Electrolytic Capacitors	120 Hz	Small enough not to change value	$\pm 2\frac{1}{2}\%$	R or RC	Optional; but if substantial difference occurs, rated dc should be used.
RS 205 Electrolytic Capacitors for use in Electronic Instruments	120 Hz	Small enough not to change value	$\pm 2\frac{1}{2}\%$	D	Optional

General Radio Experimenter reference, Vol. 40, No. 6, June 1966.



TABLE OF CONTENTS

Section 1 INTRODUCTION	1
1.1 Purpose	1
1.2 Description	1
1.3 Accessories Supplied	1
1.4 Controls, Connectors, and Indicators (Figure 1-2)	2
1.5 Symbols, Abbreviations, and Definitions	4
1.6 Operator Safety	4
Section 2 INSTALLATION	5
2.1 General	5
2.2 Mounting	5
2.3 Power Connection	7
Section 3 OPERATING PROCEDURE	9
3.1 Connection of the Unknown Capacitor	9
3.2 Capacitance Measurement Procedure – Internal Generator	10
3.3 Leakage Current Measurement	11
3.4 Voltage Measurement Accuracy	12
3.5 Maximum Discharge Energy	12
Section 4 SPECIAL MEASUREMENTS	13
4.1 Use of an External Generator	13
4.2 Use of an External Microammeter	14
4.3 Use of an External Bias Supply	14
4.4 Use of the Normal/Reverse Positions	15
4.5 Other Applications	15
Section 5 PRINCIPLES OF OPERATION	19
5.1 Bridge Circuits	19
5.2 Guard Circuit	21
5.3 The Internal Generator	21
5.4 Internal Detector	22
5.5 The Bias Voltage Supply	22
5.6 Orthonull	22
5.7 Three-and-Four-Terminal Measurements	23
5.8 General	25
Section 6 SERVICE AND MAINTENANCE	27
6.1 Warranty	27
6.2 Service	27
6.3 Trouble Analysis	27
6.4 Detail Trouble Analysis (Figure 6-1)	28
6.5 Calibration Procedure	31
6.6 Flip-Tilt Cabinet	33
6.7 Repair and Replacement	33
6.8 Minimum Performance Standards	33
6.9 Knob Removal	36
6.10 Knob Installation	36
6.11 Meter Window Care	36





GenRad

WARRANTY

We warrant that this product is free from defects in material and workmanship and, when properly used, will perform in accordance with GenRad's applicable published specifications. If within one (1) year after original shipment it is found not to meet this standard, it will be repaired or at the option of GenRad, replaced at no charge when returned to a GenRad service facility.

CHANGES IN THE PRODUCT NOT APPROVED BY GENRAD SHALL VOID THIS WARRANTY.

GENRAD SHALL NOT BE LIABLE FOR ANY INDIRECT, SPECIAL, OR CONSEQUENTIAL DAMAGES, EVEN IF NOTICE HAS BEEN GIVEN OF THE POSSIBILITY OF SUCH DAMAGES.

THIS WARRANTY IS IN LIEU OF ALL OTHER WARRANTIES, EXPRESS OR IMPLIED, INCLUDING, BUT NOT LIMITED TO, ANY IMPLIED WARRANTY OF MERCHANTABILITY OR FITNESS FOR A PARTICULAR PURPOSE.

SERVICE POLICY

Your local GenRad office or representative will assist you in all matters relating to product maintenance, such as calibration, repair, replacement parts and service contracts.

GenRad policy is to maintain product repair capability for a period of five (5) years after original shipment and to make this capability available at the then prevailing schedule of charges.



Introduction – Section 1

WARNING

To minimize electrical shock hazard, it is recommended that bias voltages be limited to 30 volts maximum. For certain applications, under proper conditions, up to 800 volts can be used.

When bias voltages greater than 30 volts are used exercise extreme care. Full bias voltage appears on panel binding posts, test leads, test fixtures and on the leads of the capacitor under test.

As the first step in the operating procedure, check that the CAPACITOR CHARGED and DANGER – BIAS ON warning lights glow as the capacitor under test becomes charged. If either warning light does not glow, turn off the bias source and bridge power immediately, and refer the bridge to properly qualified personnel for correction of the malfunction.

Capacitors remain charged after measurement. The user must follow safe procedures to assure proper discharge of capacitors after measurement.

For their safety, all personnel operating this bridge must be made aware of the potential shock hazard involved in measuring biased capacitors.

Do not leave the bridge unattended with bias applied.

1.1 PURPOSE.

The Type 1617 Capacitance Bridge, an entirely self-contained system, measures capacitance and dissipation factor of practically any capacitor, and is particularly designed to test tantalum or aluminum electrolytic capacitors at 120 Hz per MIL and EIA specification (refer to specifications).

It measures dc leakage current with a resolution of about 1 μ A and in general is a good 1% capacitance bridge. It permits two-, three-, four- and even five-terminal measurements of capacitance and dielectric loss of insulating materials, cables, and transformers, even if remotely located.

1.2 DESCRIPTION.

The Type 1617 Capacitance Bridge is a modified form of the standard series-RC bridge. It operates from conventional 60-Hz power lines (50-Hz versions available), and is completely self-contained, including a 120-Hz generator, a selective detector, and a dc bias. Provisions have also been made for use of an external ac generator and dc bias supply. Accuracy is 1% between 40 Hz and 1kHz over most of the capacitance range.

To achieve the 1% accuracy over this wide capacitance range, 3- and 4-terminal connections as well as

2-terminal connections are provided. On high-capacitance ranges, where impedance is so low that leads have a significant effect on the D reading, a 4-terminal connection can be used. On low-capacitance ranges, where stray capacitance may cause a significant error in C measurement, a 3-terminal connection may be used.

Because the internally generated polarizing voltage can be as high as 600 volts, two panel lights are provided as safety features, one to indicate that the biasing switch is thrown, the other to indicate that the charge on the unknown capacitor exceeds 1 volt.

1.3 ACCESSORIES SUPPLIED.

Table 1-1 lists the accessories supplied with the Type 1617 bridge.

Table 1-1
Accessories Supplied

Quantity	Description	Part Number
1	Cable assembly for guarded measurements	1617-2200
1	Cable assembly for 4-terminal measurements	1617-2210

1.4 CONTROLS, CONNECTORS, AND INDICATORS

Table 1-2 lists and describes front-panel controls, connectors and indicators on the Type 1617 bridge.

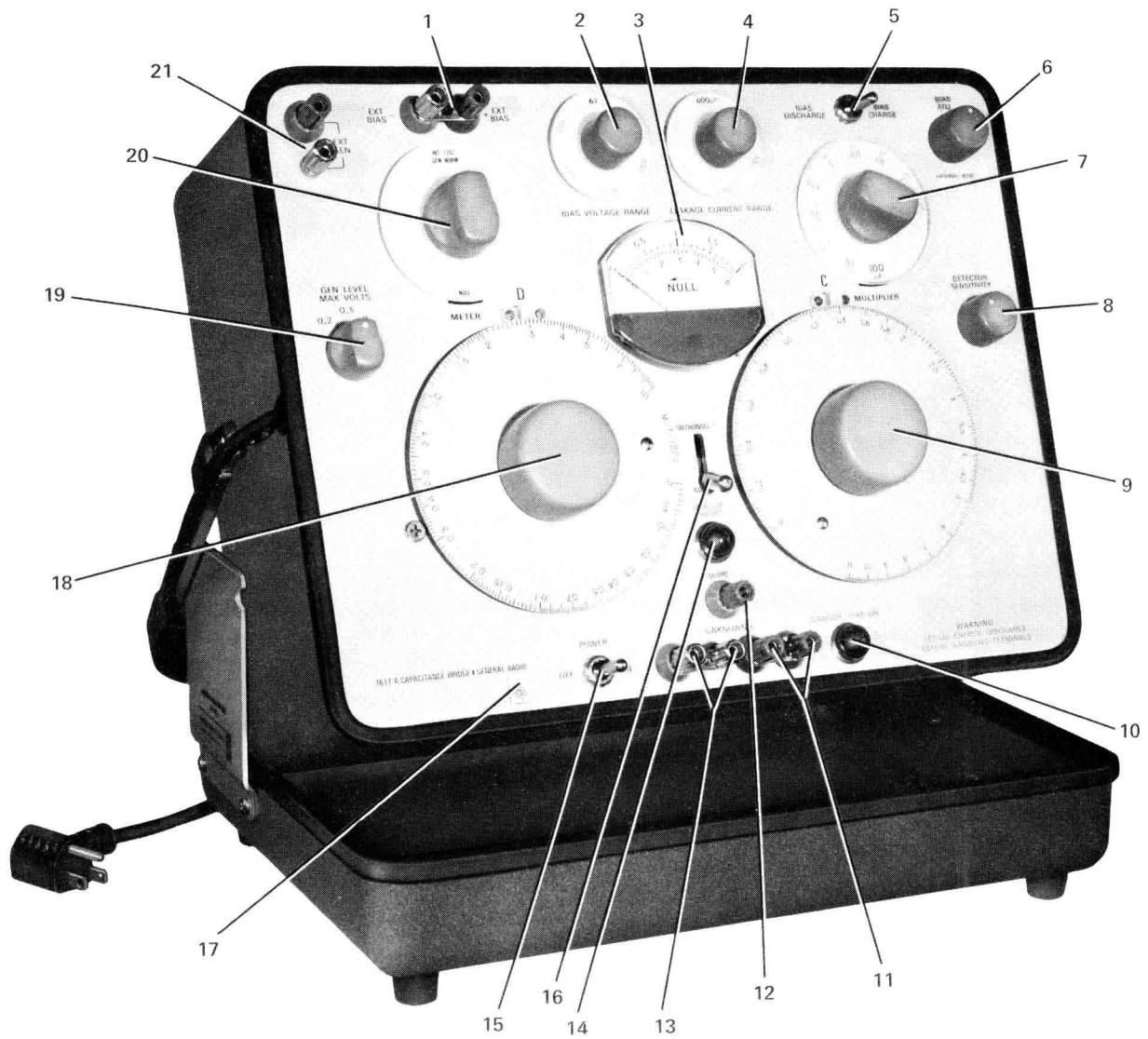

Figure 1-1. Controls, connectors and indicators.

2 INTRODUCTION



Table 1-2
Controls, Connectors and Indicators
(See Figure 1-1)

<i>Ref</i>	<i>Control</i>	<i>Type</i>	<i>Function</i>
1	EXT BIAS	Binding-post pair, 3/4-inch spaced	Allows connection of an external dc-bias voltage of up to 800 V.
2	BIAS VOLTAGE RANGE	Six-position rotary switch	Selects internal dc bias supply and corresponding meter ranges; 2, 6, 20, 60, 200, or 600 V.
3	NULL meter	50- μ A meter	Measures detector output voltage, (null), bias voltage, or leakage current as determined by function control.
4	LEAKAGE CURRENT RANGE	Six-position rotary switch	Selects leakage-current range of NULL meter when function control (20) is set to LEAKAGE CURRENT. Full-scale currents are 60, 200, or 600 μ A; 2, 6, or 20 mA.
5	BIAS switch	Two-position toggle switch	Allows internal or external bias voltage to be applied to or removed from capacitor under test.
6	BIAS ADJUST	Combination switch-potentiometer	Extreme counter-clockwise position (EXTERNAL BIAS) allows application of bias from external power supply via EXT BIAS terminals. Over remainder of range, allows continuous adjustment of internal dc bias from 0 to maximum value determined by BIAS VOLTAGE RANGE control.
7	MULTIPLIER	Ten-position rotary switch	Multiplier control for capacitance dial: 100 pF; 1, 10, or 100 nF; 1, 10, or 100 μ F; 1, 10, or 100 mF.
8	DETECTOR SENSITIVITY	Potentiometer control	Provides continuously adjustable detector sensitivity for bridge measurement.
9	C dial	Potentiometer control with calibrated dial	Main balance control for capacitance.
10	DANGER-BIAS ON	Incandescent lamp	Lit when BIAS switch is in CHARGE position, to warn of possible lethal energy at UNKNOWN terminals.
11	+UNKNOWN	Binding-post pair, 3/4-inch spaced	Allows connection of positive side of unknown capacitor.
12	GUARD	Single binding post	Furnishes guard voltage for 3-terminal measurements to reduce stray capacitance.
13	-UNKNOWN	Binding-post pair, 3/4-inch spaced	Allows connection of negative side of unknown capacitor.
14	CAPACITOR CHARGED	Incandescent lamp	Lit when charge on capacitor exceeds one volt.
15	POWER	Two-position toggle switch	Energizes instrument.
16	ORTHONULL	Mechanical lever	Engages Orthonull mechanism to simplify balance operation, to avoid false nulls and sliding balances with lossy capacitors ($D > 1$).
17	Pilot Lamp	Incandescent lamp with GR monogram	Lit when POWER switch is ON.
18	D dial	Potentiometer control with calibrated dial	Main balance control for dissipation factor.
19	GEN LEVEL MAX VOLTS	Three-position rotary switch	Selects generator voltage applied to the bridge: 0.2, 0.5, or 2 V, rms. The ac voltage on the unknown capacitor will always be less.
20	Function switch	Six-position rotary switch	Selects generator source and polarity (INT NORM, INT REV, EXT NORM, or EXT REV) and meter indication (NULL, BIAS VOLTAGE, or LEAKAGE CURRENT).
21	EXT GEN	Binding-post pair, 3/4-inch spaced	Allows connection of an external generator; 40 Hz to 1 kHz, 1 W, max.



1.5 SYMBOLS, ABBREVIATIONS, AND DEFINITIONS.

Definitions for symbols used on the panel of the Type 1617 and for abbreviations used in this instruction manual are as follows:

C capacitance (see below for units)

C_s series capacitance $C_s = (1 + D^2) C_p$

C_p parallel capacitance $C_p = \frac{1}{1 + D^2} C_s$

L inductance (see below for units)

R resistance, the real part of an impedance – (see below for units)

R_s series resistance

R_p parallel resistance

X reactance, the imaginary part of an impedance

Z impedance

D dissipation factor $\frac{R}{X} = \frac{1}{Q}$

for capacitors $= \omega C_s R_s = \frac{1}{\omega C_p R_p}$

PF power factor $= \frac{R}{|Z|} = \frac{R}{\sqrt{R^2 + X^2}} = \frac{D}{\sqrt{1 + D^2}}$

ESR equivalent series resistance $= R_s = \frac{D}{\omega C_s}$

f frequency in hertz (Hz)

ω angular frequency (rad/sec) $= \omega = 2\pi f$

F farad, unit of capacitance

mF millifarad $= 10^{-3}F = 10^3\mu F$

μF microfarad $= 10^{-6}F = 10^3nF = 10^6pF$

nF nanofarad $= 10^{-9}F = 10^{-3}\mu F = 10^3pF$

pF picofarad $= 10^{-12}F = 10^{-6}\mu F = 10^{-3}nF$

Ω ohm, unit of resistance

m Ω milliohm $= 10^{-3}\Omega$

k Ω kilohm $= 10^3\Omega$

M Ω megohm $= 10^6\Omega = 10^3k\Omega$

H henry, unit of inductance

mH millihenry $= 10^{-3}H$

μH microhenry $= 10^{-6}H$

nH nanohenry $= 10^{-9}H$

1.6 OPERATOR SAFETY.

Measurements on charged capacitors are inherently dangerous. The Type 1617 Capacitance Bridge, being a self-contained instrument, is naturally safer than a temporary clip-lead set up and all possible safety features were included in its design. The operator must follow instructions at all times to ensure safe use of the instrument.

Connect or disconnect the capacitor to be tested only when both warning lights are off. This means that bias is not applied (CHARGE-DISCHARGE switch on the DISCHARGE position) and that there is less than 1 volt across the capacitor.

Do not rely solely on the warning lights (the lamps might burn out), especially if repeated measurements are to be made; use insulated test clips, rubber gloves, and a chair insulated from the ground.

Several capacitors in the instrument itself can carry charges of lethal energy; they are safe only when both warning lights are off.

When no bias is to be applied, set the VOLTAGE/RANGE switch to 2 V, the BIAS ADJ to EXT, and the CHARGE-DISCHARGE switch to DISCHARGE. Under these conditions, an accidental change in the setting of one of the controls will not endanger the operator.

If the bridge is never going to be used with internal dc bias, the bias supply can be disabled by disconnection of the leads to pins 10 through 15 on the power-transformer plate (see Figure 6-2). If only the lower bias voltages are to be used, the higher voltages can be eliminated by disconnection of pin 12 of the power transformer and by shorting the appropriate resistor (Table 1-3).

Table 1-3
Bias Range Variation

<i>Resistor Shorted</i>	<i>Value</i>	<i>Range Eliminated</i>
R115	402 K	600 V
R154	140 K	200 V
R153	40.2 K	60 V
R152	14 K	20 V
R151	4.02 K	6 V

Installation – Section 2

2.1 GENERAL.

2.1.1 DIMENSIONS.

The over-all dimensions for the bridge are shown in Figure 2-1.

2.1.2 ENVIRONMENTAL CONSIDERATIONS.

The Type 1617 bridge is designed to operate at ambient temperatures from 0 to 50°C and to be stored at temperatures from -40 to +70°C.

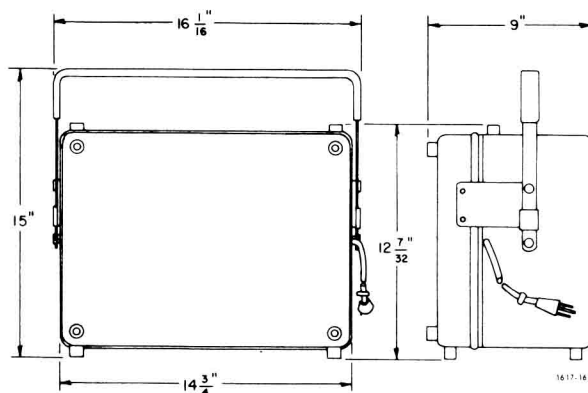

2.2 MOUNTING.

The Type 1617 Bridge is supplied in portable mechanical configurations. An adaptor set (P/N 0481-9759) converts the portable model to rack model. Each adaptor set contains a relay-rack panel, a hardware set, and instructions for rack mounting. A rack model can be stack mounted for bench use in combinations with other instruments.

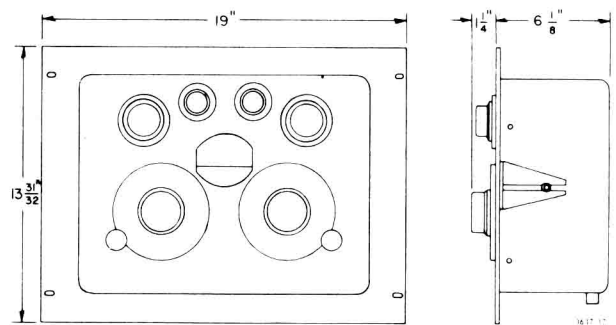
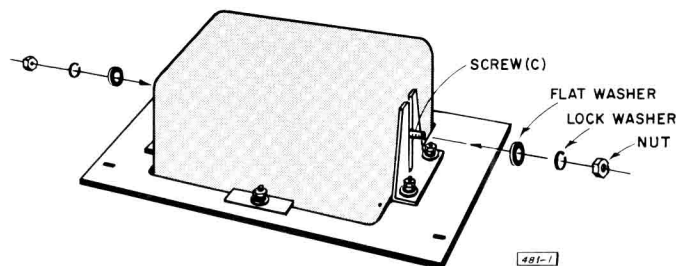
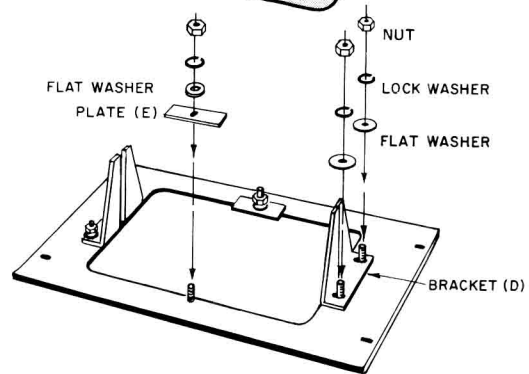
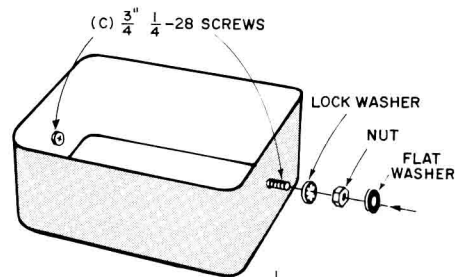
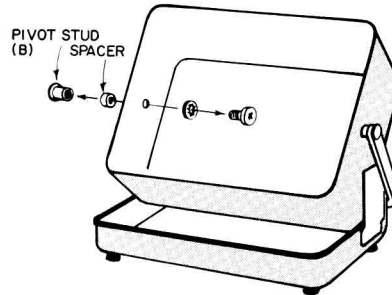
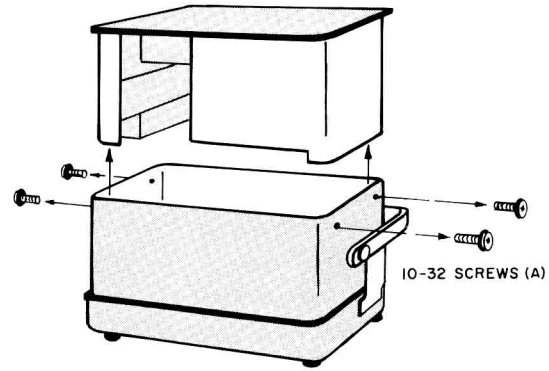

Figure 2-1. Dimensions of the Type 1617 bridge in the portable and rack models.

2.2.1 PORTABLE TO RACK MOUNT CONVERSION.
(Figure 2-2).

To convert from portable to rack mount:

- a. Open the instrument fully to its horizontal position.
- b. Remove the 10-32 screws (A) that secure the instrument to the cabinet and lift the instrument out of the cabinet.
- c. Remove the pivot studs (B) and lift the cabinet off the cover-and-handle assembly.
- d. Attach 1/4-28 screws (C) in place of the pivot screws. Secure them with 1/4-inch lockwashers and nuts and then add a 1/4-inch flatwasher to each screw.
- e. Replace the instrument in the cabinet and secure it with the 10-32 screws (A), removed earlier.
- f. Attach the brackets (D) to the panel with no. 10 lockwashers and nuts; do not tighten.
- g. Add a no. 10 flat washer to the top and bottom lugs, and attach the plates (E) with no. 10 lockwashers and nuts; do not tighten.
- h. Place the panel over the instrument; slide the slit in each bracket over the 1/4-28 screw (C), keeping the flatwasher between the instrument and the bracket.
- i. Slide the plates over the gasket, align the assembly, and tighten all nuts.



2.2.2 RACK-TO-PORTABLE CONVERSION.

To convert a rack instrument for portable use, follow the reverse procedure given in paragraph 2.2.1. The parts required for this conversion are listed in Table 2-1.

Quantity	Description	Part No.
1	Handle and Bracket Assembly	1617-2010
1	Cover Assembly	4170-2086
2	Pivot Stud	4170-1000
2	Plate Nut	4170-1376
2	Spacer	4170-0700
2	Screw, No. 1/4-28, 3/8	7040-0400
4	Screw, No. 10-32, 3/8	7080-1000
4	Washer	8040-2400
2	Washer	8050-0100

Figure 2-2. Procedure to rack mount a portable model.

2.2.3 STACK MOUNTING.

A rack model can also be stack mounted with other GR relay-rack instruments fitted with end frames for bench use. Stack-mounted accessories required for the Type 1617 are listed in Table 2-2 and mounting instructions (Form 5301-0145A) are available with the accessories.

Table 2-2

Stack-Mounting Accessories Required		
Quantity	Part Number	Description
1	5310-9682	End-frame set
1	5310-3301	Hardware Set

2.3 POWER CONNECTION.

2.3.1 GENERAL.

Use the attached three-wire power cord to connect the bridge to a source of power as indicated on the tag located on the cabinet beneath the power cord (Figure 2-3). The long cylindrical pin (ground) is connected directly to the metal case of the instrument, hence to the EXT GEN ground connector and -UNKNOWN ground connector on the front panel.

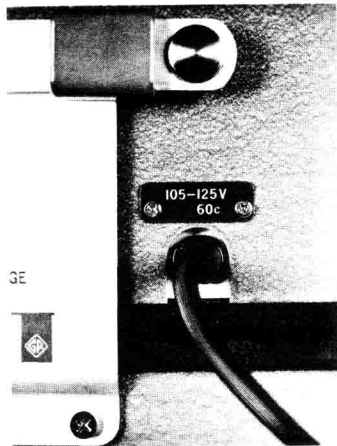

Figure 2-3. Indication of the source of power to be used.

2.3.2 115-VOLT LINE.

Power required is 105 to 125 V, 50 or 60 Hz (depending on model of bridge), 18 W. An input plate for 115-V operation, P/N 5590-0700, is used for 60-Hz models; P/N 5590-1163 for 50-Hz models. It attaches to the cabinet beneath the power cord by means of two 4-40 x 3/16 screws with attached lockwashers, P/N 7090-4030. On the terminal plate of the power transformer (Figure 6-2), terminal 1 is connected to terminal 3 and terminal 2 to terminal 4. Fuses for F501 and F502 are 0.2 A, P/N 5330-0600 each (Figure 6-13).

2.3.3 230-VOLT LINE.

Power required is 210 to 250 V, 50 or 60 Hz (depending on model of bridge), 18 W. An input plate for 230-V operation, P/N 5590-1667, is used for 60-Hz models; P/N 5590-1666 is used for 50-Hz models. It attaches to the cabinet beneath the power cord by means of two 4-40 x 3/16 screws with attached lockwashers, P/N 7090-4030. On the terminal plate of the power transformer, terminal 2 is connected to terminal 3. Fuses for F501 and F502 are 0.1 A, P/N 5330-0400 each (Figure 6-13).

2.3.4 CONNECTIONS.

The EXT GEN, EXT BIAS and UNKNOWN terminals are standard 3/4-inch-spaced binding posts which accept banana plugs, standard telephone tips, alligator clips, crocodile clips, spade terminals and all wire size up to number ten.

Two plug-in cable assemblies are supplied with the bridge expressly for the UNKNOWN terminal.

The two-cable assembly (Figure 3-2) has a shielded positive terminal. The shield is connected to the guard and the two positive and the two negative terminals are linked internally. It should be used for three-terminal measurements (refer to paragraph 3.1).

The four-cable assembly (Figure 3-3) is used for four terminal measurements (refer to paragraph 3.1). The cables of both assemblies are terminated in clip leads in an insulated rubber sleeve.

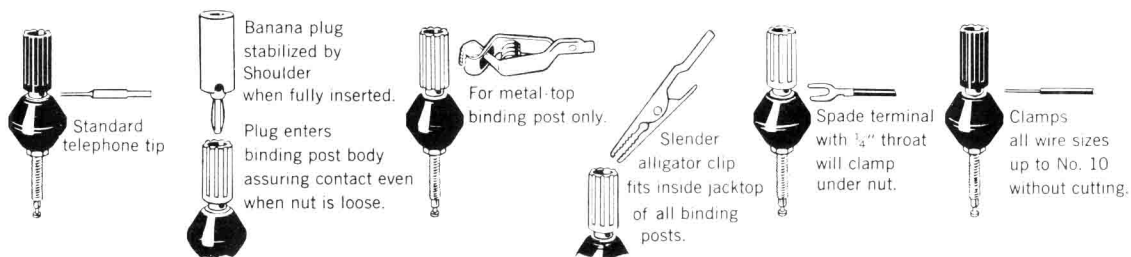

Methods of connection to the measurement terminals.

Operation – Section 3

WARNING

It is possible to apply lethal voltage across a capacitor by means of this bridge. The energy stored in the unknown capacitor, and even in the internal capacitor, can be extremely dangerous to the operator; please follow the instructions carefully.

Never connect or disconnect anything at the UNKNOWN terminals unless the BIAS CHARGE-DISCHARGE switch is on DISCHARGE and the two warning lamps are off.

When no bias voltage is applied, set the VOLTAGE RANGE switch to 2 V, the BIAS ADJ to EXT and the BIAS CHARGE-DISCHARGE switch to DISCHARGE.

When operating the bridge at high voltage level, use every possible precaution to avoid contact with the UNKNOWN terminals, or the positive terminal of the capacitor under test.

3.1 CONNECTION OF THE UNKNOWN CAPACITOR.

3.1.1 GENERAL.

The panel of the Type 1617 Capacitance Bridge offers five separate terminals at which to connect the unknown. There are two current terminals, two potential terminals and one guard terminal; two shorting links are also provided Figure 3-1. This array permits two-, three-, four-, and five-terminal measurements, as dictated by the value of the unknown and its location.

3.1.2 LOW-VALUED CAPACITORS.

In this range (less than 10 nF), since shunt stray capacitance is apt to introduce an important error, three-terminal connections should be made. The supplied plug-in cable assembly (P/N 1617-2200) achieves this connection simply (Figure 3-2). The linkage of the positive and the negative terminals is achieved internally in the assembly. It can also be done as follows: Connect the inner conductor of a shielded cable to either positive terminal, the shield of the cable to the guard terminal, and any clip lead to either negative terminal (both positive and negative terminals should be

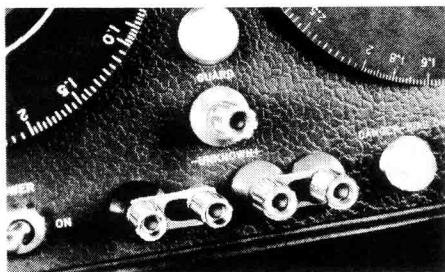

Figure 3-1. UNKNOWN and GUARD terminals on the bridge.

linked). Then connect the unknown at the end of the two cables and proceed with the measurement.

The residual ("zero") of the bridge (i.e., the reading of the C dial when the bridge is balanced while on the lowest range with the unknown disconnected) is to be subtracted from the C reading. It is small (about 4 pF) and can be considered negligible on the other ranges.

3.1.3 MEDIUM-VALUED CAPACITORS.

Capacitance measurements in this range (about 10 nF to 100 μ F) are not appreciably affected by shunt capacitance or series impedances, unless the leads are more than a few feet long. Therefore, most any type of clip leads may be used although the two-lead cable assembly supplied, P/N 1617-2200, is particularly convenient.

If the leads are very long, the lower capacitance values should be connected with a guarded, shielded cable and the higher values should use a four-lead connection (see paragraph 4.5.1).

NOTE

In 2- and 3-terminal measurements, when the assembly is not used, the bridge will not balance unless the shorting links are connected.

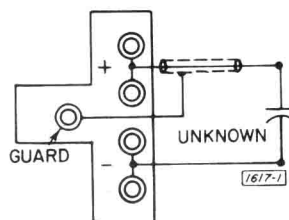

Figure 3-2. Schematic of the 3-terminal connection (guarded), using the two-lead plug-in assembly (P/N 1617-2200).

3.1.4 HIGH-VALUED CAPACITORS.

For the range 100 μ F to 10mF of capacitance, the lead impedance might introduce a sizeable D error in a two-terminal measurement. For example, 100 μ F measured with the supplied two-lead cable assembly at 120 Hz gives a D reading higher than the actual value by 0.005.

Four-terminal measurements are necessary for better D accuracy. The bridge connection is made convenient with the supplied cable assembly (P/N 1617-2210). When a four-lead connection is made to a capacitor (Figure 3-3), the bridge will measure the effective capacitance and loss of the impedance between the junction of the two positive leads and the junction of the two negative ones. In effect, the unknown starts where it becomes two-terminal. Figure 3-4 shows different types of four-terminal connections, the effective impedance measured by the bridge being from A to B.

NOTE

Disconnect the shorting links when making four-terminal measurements.

3.1.5 VERY HIGH VALUED CAPACITORS.

Four-terminal connections should be used on very large capacitors (10 mF to 1 F) not only to avoid large D errors due to lead resistance, but also to avoid capacitance errors caused by lead inductance.

While a four-lead connection removes the effect of the resistance and self-inductance of each lead, some care must be used to avoid mutual inductance between the outer two ("current") leads and the inner two ("potential") leads; see Figure 3-5. Mutual inductance here causes an induced voltage that increases the effective value of the unknown. This mutual inductance can be greatly reduced by twisting together either the two outer leads or the two inner leads as shown in Figure 3-6.

This precaution against mutual inductance is also important when lower capacitance is measured at higher frequencies, because the error is a function of ω^2MC_x , where M is the total mutual inductance. There is always some mutual inductance present at the bridge terminals and this limits the range of the bridge at higher frequencies.

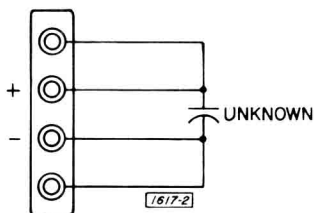

Figure 3-3. A 4-terminal connection using the four-lead plug-in assembly.

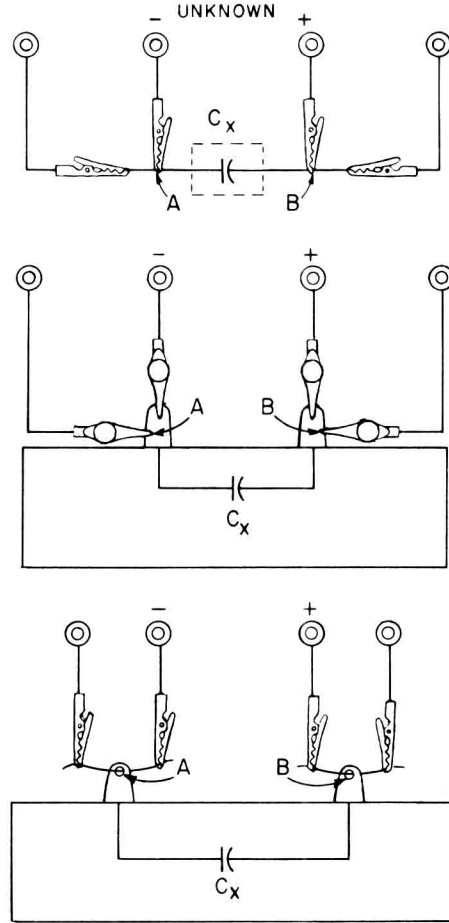

Figure 3-4. Different types of 4-terminal connections. The unknown is measured from A to B.

NOTE

The ranges indicated in the above paragraphs are quite arbitrary and are intended only as guides. The type of connection used for a given capacitance might also depend on the length of the leads, and the D and C accuracies desired.

3.2 CAPACITANCE MEASUREMENT PROCEDURE - INTERNAL GENERATOR.

3.2.1 NO BIAS APPLIED.

To measure an unknown capacitor with no bias applied proceed as follows:

Safety measures:

Place the BIAS CHARGE-DISCHARGE switch at DISCHARGE.

Set BIAS ADJ to EXT BIAS (EXT BIAS terminals must be shorted).

Set the BIAS VOLTAGE RANGE switch to 2 V.

- a. Connect the bridge to the line and turn POWER on.
- b. Connect the unknown capacitor (refer to paragraph 3.1).
- c. Set the function switch to INT 120C* either NORMAL or REVERSE.
- d. Select the maximum AC voltage desired on GEN LEVEL MAX VOLTS.
- e. Turn the DETECTOR SENSITIVITY counterclockwise (minimum sensitivity).
- f. If the approximate value is known, set the MULTIPLIER switch accordingly.
- g. Increase the sensitivity (DETECTOR SENSITIVITY clockwise) to give an upscale deflection.
- h. Adjust the C and D dials to obtain a minimum deflection on the NULL meter. Repeat this process until the best null for the highest feasible sensitivity is obtained.

NOTE

When the D of the unknown is greater than one, use the Orthonull^R (ganging the C and D dials) will avoid false nulls and speed the balance.

- i. Multiply the C-dial setting by the MULTIPLIER setting to obtain the capacitance of the unknown.
- j. Read the dissipation factor directly on the D dial.

3.2.2 BIAS APPLIED. WARNING – See Page 9.

To measure an unknown capacitor with bias applied, proceed as follows:

- a. Move the BIAS CHARGE-DISCHARGE switch to DISCHARGE.
- b. Connect the bridge to the line and turn POWER on.
- c. Connect the unknown (refer to paragraph 3.1).
- d. Set the function switch to BIAS VOLTAGE.
- e. Set BIAS VOLTAGE RANGE switch on the desired range.
- f. Move the BIAS CHARGE/DISCHARGE switch to CHARGE. DANGER-BIAS ON lamp must glow.
- g. Adjust the BIAS ADJ knob until the meter reads the desired voltage (do not exceed the rating of the unknown).
- h. Proceed with step c through j of paragraph 3.2.1.
- i. Throw the CHARGE/DISCHARGE switch on DISCHARGE before disconnecting the unknown.

3.2.3 RANGE AND ACCURACY.

With the internal generator, the C accuracy is $\pm 1\%$ ± 1 pF from 0 to 0.11 F. The residual ("zero of the bridge") to be subtracted from the reading is approxi-

*The notation C (cycles per second) is equivalent to Hz (hertz).

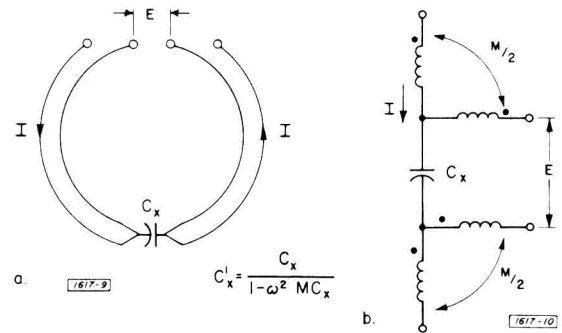

Figure 3-5. When "current" and "potential" leads form concentric loops (left), the resulting mutual inductance (right) affects the value of the capacitance being measured.

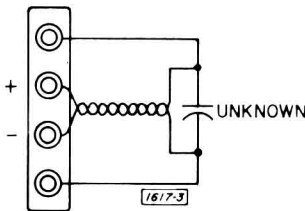

Figure 3-6. Reduction of the effect of mutual inductance in the leads.

mately 4 pF. From 0.11 to 1.1 F, the accuracy becomes $\pm 2\%$. The D accuracy ($\pm 0.001 \pm 0.01$ C in F $\pm 2\%$) depends on C. This naturally assumes that the correct connections (refer to paragraph 3.1) have been used to minimize errors.

When bias voltage is applied, the accuracy specifications are the same, but the sensitivity of the bridge is lessened by the impedance of the internal capacitor always across the bias supply (refer to paragraph 5.5).

3.3 LEAKAGE CURRENT MEASUREMENT.

3.3.1 GENERAL.

The leakage current through capacitors of most types is a function of time. A common practice for many types of capacitors is to use the value obtained after voltage is applied for two minutes, but other soaking times are also used so that this parameter should be specified.

The current measuring range of the Type 1617 is limited to $60\text{-}\mu\text{A}$ to 20-mA , full scale; $0.5\ \mu\text{A}$ can be resolved. This range is sufficient for most aluminum capacitors and some tantalum types. An external microammeter may be used for lower leakage currents (refer to paragraph 4.2). The available current from the internal power supply limits the maximum to about 15 mA. An external power supply and meter should be used if the leakage is higher than this.

3.3.2 MEASUREMENT PROCEDURE.

The procedure is as follows:

- a. Perform steps a through g of paragraph 3.2.2.
- b. Set the function switch to LEAKAGE CURRENT.

c. Set the LEAKAGE CURRENT RANGE switch on a suitable range.

d. Read the leakage current on the meter; the full-scale reading is that set in the preceding step.

e. Throw the BIAS CHARGE-DISCHARGE switch to DISCHARGE before disconnection of the unknown.

3.3.3 CHARGING TIME.

The time required to charge a capacitor from a current-linked supply is:

$$\tau = \frac{CV}{I} \text{ (seconds, farads, volts, and amperes)}$$

The capacitance is the sum of the unknown capacitance and the internal power-supply by-pass capacitance. The current is the difference between the maximum power supply current, approximately 15 mA, and the leakage current in both capacitors. For low-energy-unknown capacitors, the charging time is that of the internal capacitor, which is about 4 seconds. For high-energy capacitors, the time constant may become much longer. If charging is too slow, an external supply of higher current rating should be used.

If the internal power supply has not been used in some time, the by-pass capacitors may become somewhat leaky, resulting in very slow charging until they are reformed. This is particularly noticeable on the higher voltage ranges. Note that if the total leakage of the unknown and by-pass capacitors exceeds the available current, the voltage will never reach its correct value.

The charging time also depends on the value of the ratio-arm resistor in series with the unknown, but this delay will not be noticed on the voltmeter which reads the total voltage applied to the bridge (see Figure 3-7). However, if the capacitance range switch is set to the correct capacitance range, this time constant is negligible.

3.3.4 METER RESPONSE.

The ammeter response is purposely slow in order to protect the meter from pinning when it passes excessive current (for example, when the bias is discharged with the ammeter in the circuit). The meter

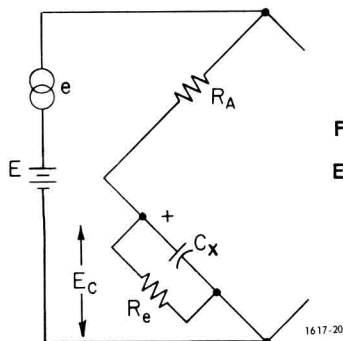

Figure 3-7. To change C_x to E_c , E must be $E_c (1 + \frac{R_A}{R_e})$.

indication may become very slow, when very large capacitors with low leakage are measured, because the meter time constant is a function of the meter-range resistor and the unknown capacitor.

The voltage applied to the unknown during leakage-current measurements is slightly reduced by the ammeter voltage drop. This drop is proportional to the meter reading and is 0.2 V at full scale. This voltage change is of little consequence except at very low applied voltages. However, it does introduce a small transient in the ammeter which may indicate the current flow necessary to re-establish equilibrium.

3.4 VOLTAGE MEASUREMENT ACCURACY.

The voltmeter indicates 2-V to 600-V full scale in six ranges with an accuracy of $\pm 3\%$. The voltage measured is the voltage applied to the bridge input and, in most cases, this is the voltage across the unknown. However, when a very leaky capacitor is measured, the voltage drop in the ratio-arm resistor caused by the high-leakage current may result in the actual voltage on the capacitor being less than the voltage indicated (see Figure 3-7). In order to obtain the proper voltage in the capacitor, the voltmeter must be set to read $E_c (1 + \frac{R_A}{R_e})$. This difficulty is very rarely encountered if the capacitance switch is set to the correct range.

3.5 MAXIMUM DISCHARGE ENERGY.

Theoretically, the maximum energy on an unknown capacitor connected to the bridge could be 320,000 joules (800 V in 1 F). This energy would certainly destroy the discharge resistor and switch if internal-discharge circuits were used. Fortunately, nobody makes a capacitor of such capability. However, large capacitors are made for special purposes (such as welding) that can damage the discharge resistors, so that an energy limit is necessary. Therefore, the maximum voltage that should be discharged by the internal circuit is given in Table 3-1.

Also, if an external bias supply is used, the rate of charging and discharging may be high enough to overheat the discharge resistors, even though the limits of Table 3-1 are not exceeded. The average power dissipated should be limited to 5 watts.

Table 3-1

Maximum voltage for Internal Discharge	
Capacitance Range	Maximum Voltage
0 to 100 μF	800 V
0.1 to 1 mF	400 V
1 to 10 mF	100 V
10 to 100 mF	20 V
0.1 to 1 F	6 V

Special Measurements – Section 4

WARNING

It is possible to apply lethal voltage across a capacitor by means of this bridge. The energy stored in the unknown capacitor, and even in the internal capacitor, can be extremely dangerous to the operator; please follow the instructions carefully.

Never connect or disconnect anything at the UNKNOWN terminals unless the BIAS CHARGE-DISCHARGE switch is on DISCHARGE and the two warning lamps are off.

When no bias voltage is applied, set the VOLTAGE RANGE switch to 2 V, the BIAS ADJ to EXT and the BIAS CHARGE-DISCHARGE switch to DISCHARGE.

When operating the bridge at high voltage level, use every possible precaution to avoid contact with the UNKNOWN terminals, or the positive terminal of the capacitor under test.

4.1 USE OF AN EXTERNAL GENERATOR.

4.1.1 CONNECTION.

The preferred connection for an external generator is at the EXT GEN terminals. The terminals are connected to the primary of the input transformer whose secondary winding is selected by the GEN LEVEL switch (Figure 4-1). If 5V, rms, is applied to the terminals, the voltage applied to the bridge will be as indicated by this switch. Note that the input to the bridge may be reversed by the function switch to check for stray coupling effects (refer to paragraph 4.4).

At low frequencies, more voltage may be applied to the bridge if the external generator is connected to the EXT BIAS terminals (Figure 4-2, see also paragraph 4.1.3). Use a shielded lead to avoid coupling to the unknown and, because the bridge is grounded, do not ground either side of the oscillator, to avoid ground loops.* If, however, bias has to be applied, it can be done as shown in Figure 4-3.

The GR 1311 Audio Oscillator is recommended as an ideal external generator for driving the Type 1617.

4.1.2 RANGE AND ACCURACY.

Table 4-1 indicates the nominal capacitance range of the Type 1617 Capacitance Bridge for better than 2% accuracy at different frequencies above 120 Hz.

The low end of the capacitance range is limited to 500 pF above 2 kHz, because of the frequency characteristic

*With oscillators which have one side of the output tied to the case, do not use the third wire of the power cord, so as not to ground the case.

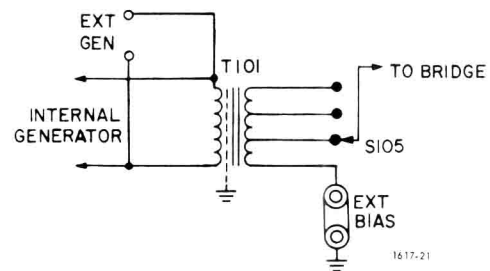

Figure 4-1. Location of the external generator connection (EXT GEN terminals).

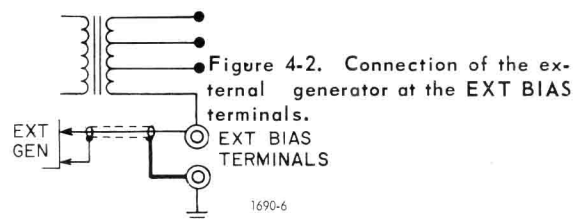

Figure 4-2. Connection of the external generator at the EXT BIAS terminals.

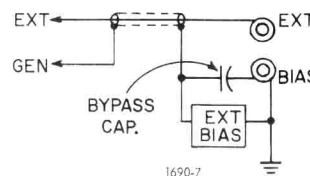

Figure 4-3. External generator and bias supply at the EXT BIAS terminals.

Table 4-1

RANGE LIMITS At Different Frequencies (Less Than 2% Error)		
Frequency	Low Limit*	High Limit**
120 Hz	50 pF	1.1 F
200 Hz	50 pF	0.5 F
500 Hz	50 pF	80 mF
1 kHz	150 pF	20 mF
2 kHz	500 pF	5 mF
5 kHz	500 pF	800 μ F
10 kHz	500 pF	200 μ F

*After zero correction.
**4-terminal measurement with twisted leads.

of the 10 $M\Omega$ ratio arm (R_A). The high end is limited by the mutual inductance in the leads and between the terminals.

The low-frequency limit is approximately 20 Hz, at which point the meter starts to follow individual cycles. Full accuracy below 30 Hz is difficult to obtain on the lowest and highest ranges, because the limit on the input voltage (refer to paragraph 4.1.3) limits the sensitivity. At low frequencies, many low-powered oscillators will not drive the input inductance (approximately 50 mH) hard enough to give sufficient sensitivity. The D accuracy is $\pm 0.001 \pm 0.01 C(\text{in F}) \pm 2\%$, from 40 to 120 Hz, and $[\pm 0.001 \pm 0.01 C(\text{in F})] \frac{f_{\text{Hz}}}{120} \pm 2\%$, above 120 Hz.

4.1.3 MAXIMUM AC VOLTAGE AND POWER.

The maximum voltage that should be applied to the EXT GEN terminals is $\frac{1}{10} f_{\text{Hz}}$ or 10 V, rms, whichever is less. The maximum ac applied to the EXT BIAS terminals is 4 V, rms. Actually, more voltage (but less than 100 V) may be applied to the bridge when the C dial is set up-scale as long as the voltage on the UNKNOWN does not exceed 4 V (which would overdrive the guard amplifier).

Thus, the above fixed limits may be multiplied by:

$$\sqrt{1 + (0.0063 \times f \times C \text{ dial reading})^2}$$

The power input should be limited to 1 watt. (The output of the GR 1311 is limited to 1 watt.)

4.1.4 MEASUREMENT PROCEDURE.

The procedure is the same as with the internal generator except that the function switch must be set to EXT GEN NORMAL or REVERSE, and the D reading must be multiplied by $\frac{f_{\text{Hz}}}{120}$. The generator level is adjusted on the external generator.

4.2 USE OF AN EXTERNAL MICROAMMETER.

The lowest range of the microammeter on the Type 1617 Capacitance Bridge is 60 μ A, full scale. Some

electrolytic capacitors (tantalum, in particular, and many other types) will require more sensitivity. This is easily accomplished by use of a sensitive external meter, such as the Type 1230 Electrometer (measures from ± 1 mA down to 0.3 μ A, or 0.3×10^{-12} A, full scale). The Weston 1946T (available in 5, 10 or 20- μ A, full-scale versions, with 2% accuracy) or the Westinghouse 371 (3% accuracy, 20 μ A full scale), are acceptable substitutes.

Connect the external meter in series with the unknown, with its negative terminal to the negative terminal of the bridge (Figure 4-4). It is now part of the unknown and has to be shorted out in a capacitance measurement to avoid error, or when charging the capacitor to avoid overload.

- Turn ac signal off when making leakage-current measurements by setting the METER switch to BIAS VOLTAGE.
- With the 4-terminal connection shown, note that the + meter terminal is grounded, so that the - terminal cannot be grounded. Also, in this connection keep the meter voltage drop below 0.1 V. (There are rectifiers between the two -1617 terminals).

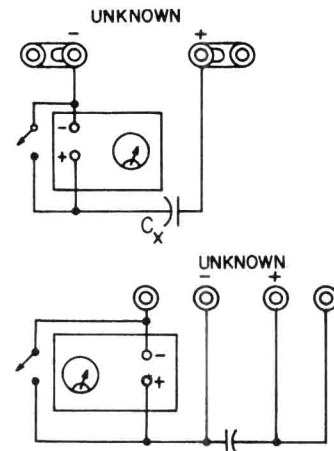

Figure 4-4. Use of an external ammeter for 2-terminal measurement, (top), 4-terminal measurement (bottom).

4.3 EXTERNAL BIAS SUPPLY (Table 3-1).

The internal bias supply will apply up to 600 V to the unknown; up to 800 V can be applied by use of an external dc supply. To apply external bias:

- Set the BIAS ADJ switch to EXTERNAL BIAS.
- Remove the shorting link from the EXT BIAS terminals and connect the power supply to these terminals.
- To preserve the sensitivity of the bridge, the effective ac impedance of the supply has to be very low, and this is ensured by placing a bypass capacitor as shown in Figure 4-5. This capacitor should be at least of the same order of magnitude as the unknown.

WARNING

The bypass capacitor has the same bias voltage across it as the unknown. Make sure the dc supply is off and the BIAS CHARGE-DISCHARGE switch is on DISCHARGE before disconnecting or connecting it.

The measurement procedure, once the external dc supply is connected, is the same as with the internal bias supply. The energy available from the external bias supply should be limited to 1 W so that if the unknown is shorted, the bridge ratio-arm resistor will not be damaged.

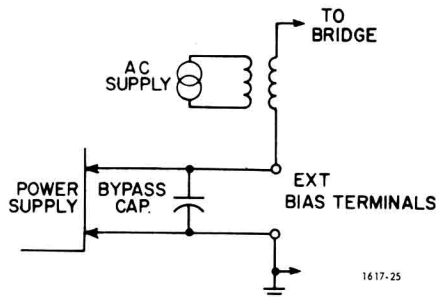

Figure 4-5. Connection of the external bias supply.

4.4 USE OF THE NORMAL/REVERSE POSITIONS.

Because the bridge test signal is synchronous with the power line, 120-Hz hum pickup will cause a bridge error. The NORMAL/REVERSE positions of the function switch allow the test signal to be reversed (Figure 4-6) with respect to the power line, so that the presence of pickup can be ascertained.

Should the D or C readings differ between balances on the NORMAL and REVERSE position, the best answer is the average of the two readings. This difficulty is most likely to occur on the lowest or highest ranges. Use the maximum possible signal level to reduce the effect.

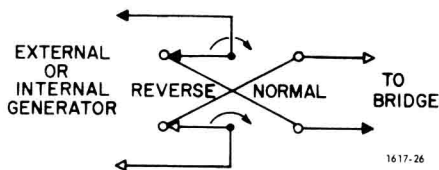

Figure 4-6. The reversing switch.

4.5 OTHER APPLICATIONS.

4.5.1 REMOTE MEASUREMENTS.

When long leads are used, the two principal sources of error are the lead impedance (it can be several ohms)

and the stray capacitance. For D accuracy, four-lead connections are necessary, and to reduce the stray capacitances, the positive lead should be shielded and the shield guarded.

When both errors may be important, a five-terminal measurement can be made (Figure 4-7).

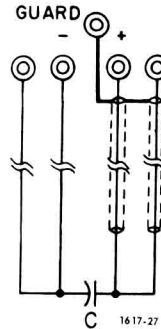

Figure 4-7. A 5-terminal connection.

4.5.2 INDUCTANCE MEASUREMENT.

Series Substitution Method. Inductance can be determined from the measurement of the net effective capacitance of the unknown inductor in series with a known capacitor of suitable value. The series capacitor must be small enough so that the net reactance of the combination is capacitive, and it must be large enough so that a significant change in effective capacitance results. Proceed as follows:

- Connect the inductor and the capacitor in series (Figure 4-8) to the bridge.
- Short circuit the inductor and balance the bridge. Observe the C and D readings. Call them C_1 and D_1 .
- Remove the short circuit and rebalance the bridge. Call the new readings C_2 and D_2 .
- Compute the series inductance (L_s) and the series resistance (R_s) from:

$$L_s = \frac{C_2 - C_1}{\omega^2 C_1 C_2} \quad R_s = \frac{D_2 C_1 - D_1 C_2}{\omega C_1 C_2}$$

with the C's in farads and the D's in absolute values.

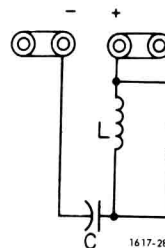

Figure 4-8. Inductance measurement by the series-substitution method.

Parallel substitution Method. For measurements using the parallel substitution method, proceed as follows:

a. Connect the unknown inductor and the capacitor in parallel (Figure 4-9).

b. Disconnect the high lead of the inductor and balance the bridge. Observe the C and D readings. Call them C_1 and D_1 .

c. Connect the inductor and rebalance the bridge. Call the new reading C_2 and D_2 .

d. Convert C_1 and C_2 To C_1' and C_2' , the effective parallel value, with

$$C' = \frac{C}{1 + D^2}$$

e. Compute the parallel inductance (L_p) and resistance (R_p) from

$$L_p = \frac{1}{\omega^2 (C_1' - C_2')} \quad R_p = \frac{1}{\omega (D_2 C_2' - D_1 C_1')}$$

with the C's in farads and the D's in absolute values.

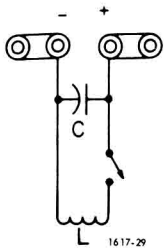

Figure 4-9. Inductance measurement by the parallel-substitution method.

4.5.3 SERIES AND PARALLEL COMPONENTS.

An impedance that is neither a pure reactance nor a pure resistance may be represented, at any specific frequency, by either a series or a parallel combination of resistance and reactance. The values of resistance and reactance used in the equivalent circuit depend on whether a series or a parallel combination is used. The equivalent circuits are shown in Figure 4-10.

The relationships between the circuit elements are:

$$Z = R_s + \frac{1}{j\omega C_s} = \frac{R_p}{R_p + \frac{1}{j\omega C_p}} = \frac{D^2 R_p + \frac{1}{j\omega C_p}}{1 + D^2}$$

$$D = \frac{1}{Q} = \omega R_s C_s = \frac{1}{\omega R_p C_p}$$

$$C_s = (1 + D^2) C_p; \quad C_p = \frac{1}{1 + D^2} C_s$$

$$R_s = \frac{D^2}{1 + D^2} R_p; \quad R_p = \frac{1 + D^2}{D^2} R_s$$

$$R_s = \frac{D}{\omega C_s}; \quad R_p = \frac{1}{\omega C_p D}$$

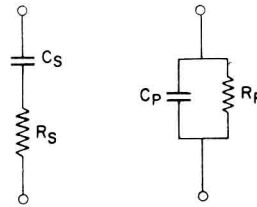

Figure 4-10. Series and parallel equivalent circuits.

4.5.4 DIELECTRIC SAMPLES MEASUREMENT.

The dielectric constant and dissipation factor of an insulating material can be determined from the measurement of the capacitance and dissipation factor of an elementary capacitor, with the material used as the insulating medium between metallic electrodes of suitable dimensions.

Two-Electrode Method. A simple two-electrode method is sufficient for most purposes. The procedure is as follows:

a. If possible, choose a sample of such shape and dimensions as to yield a capacitance of 100 pF or more. The calculation of dielectric constant is simplified if the thickness and area are easily measured and calculated, such as a disk or rectangle. If measurements are to be made at various frequencies, it is best to use sizes and shapes as specified in ASTM-D-150 (available from American Society for Testing Materials, 260 Race Street, Philadelphia, Pennsylvania).

b. Measure and record the dimensions of the sample, and clean it thoroughly. (A mixture of half grain alcohol and half ether is recommended, unless either is a solvent for the material.)

c. When the sample is dry, apply a very thin film of refined petrolatum to one surface. Place a thin metal-foil electrode, preferably less than 1 mil thick, and larger than the sample, on this surface.

d. Press the electrode in place with a pad of cloth or squeegee roller and rub out any air bubbles, so that the foil is in intimate contact with the surface. Then trim the foil to the same size as the sample.

e. Apply the other electrode to the sample as described in steps c and d.

NOTE

An alternate method of forming electrodes is to brush a good silver paint (such as Dupont No. 4132 Silver Paste) on the sample and to dry it overnight at 60°C. Such an electrode is porous to moisture, so that the dielectric can be conditioned at any desired relative humidity without removing the electrode.

f. Measure capacitance as described in paragraph 3.2.

g. Compute dielectric constant (to a first approximation) as follows:

$$K = \frac{4.45 tC}{A}$$

where K is dielectric constant

t is thickness of the sample, in inches

C is measured capacitance, in pF

A is area of the electrodes, in square inches.

For a complete discussion of the effects of stray electric field at the edges of the electrodes, and the effect of the capacitance of the high electrode to ground, refer to ASTM-D-150.

Three Electrodes Method. The guard arrangement (Figure 4-11) provides an electrical equivalent to a 3-terminal capacitance, and is measured as such.

4.5.5 LIQUID INSULATION MEASUREMENT.

Liquid insulation, such as transformer oil, requires some type of cell for measurement of capacitance and dissipation factor. The cell in its simplest form can be a multiple-plate air capacitor immersed in the liquid, or a grounded cylindrical can with a slightly smaller insulated cylindrical electrode. Such cells do not allow the accurate calculation of dielectric constant, nor do they maintain a constant voltage gradient of the liquid. These difficulties are overcome by the use of a three-electrode cell, such as described in ASTM-D-150. Such a cell is electrically equivalent to Figure 4-11 and permits a 3-terminal measurement.

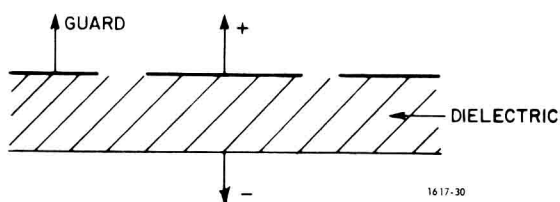

Figure 4-11. Guard-electrode arrangement to measure dielectric samples.

4.5.6 TRANSFORMER INSULATION MEASUREMENT.

The insulation in a transformer, together with the primary and the secondary windings and the transformer

case, form a 3-terminal network (Figure 4-12). Usually the three capacitances are of the same order of magnitude, and any one of them can be measured directly by the bridge, if it is connected between the UNKNOWN terminals and the other two capacitances are connected to the GUARD terminal.

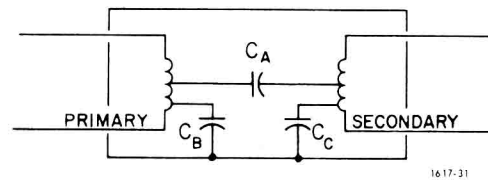

Figure 4-12. Capacitances existing in a transformer.

4.5.7 TEST JIGS.

The Type 1650-P1 Test Jig (refer to the appendix) is available from General Radio for faster measurements, it allows rapid 2- and 3-terminal measurement. Connections to the bridge are made through two Type 274-DB plugs and a clip lead to connect the guard. Special jigs can be made for different shapes of capacitors, or for 4-terminal measurements (paragraph 5.7.3). The principles discussed in paragraph 3.1.4 and 3.1.5 should be taken into account in the design of such a jig.

4.5.8 LIMIT TESTING.

The Type 1617 bridge may be set up to provide a go-no-go indication useful for component testing. The panel meter is used as the indicator. Proceed as follows:

- Balance the bridge with one of the components to be tested (one within tolerance).
- Offset the C dial from the balance position by the desired tolerance.
- Adjust the SENSITIVITY control for a center-scale meter deflection.
- Set the C dial to the nominal value of the component.
- Connect each component to the bridge. If the meter deflection is between zero and center scale, the component is within limits.

Principles of Operation—Section 5

5.1 BRIDGE CIRCUITS.

5.1.1 GENERAL.

The circuit of the Type 1617 Capacitance Bridge is basically the familiar series-capacitance-comparison type used in most general-purpose capacitance bridges. The capacitance, C , of the unknown is proportional to R_N and its dissipation factor, D , to R_S (Figure 5-1).

5.1.2 LOW CAPACITANCE.

On the lowest five capacitance ranges (up to $10 \mu\text{F}$), the circuit used is the simple one shown in Figure 5-1; (the guard circuit is connected for 3-terminal measurements). The bridge circuit is oriented so that a grounded dc supply will apply a voltage to the unknown capacitor through the ratio-arm resistor R_A . Reasonable lead resistances and inductances cause negligible errors; for example, a $0.1\text{-}\Omega$ lead resistance introduces a D error of less than 0.001 in the measurement of a $10 \mu\text{F}$ capacitor.

5.1.3 LEAD EFFECTS ON HIGH CAPACITANCE MEASUREMENTS.

One farad is only $1.3 \text{ m}\Omega$ at 120 Hz and the same $0.1\text{-}\Omega$ lead resistance will now result in a D reading of 70.

Figure 5-2 shows R_A and C_X as 4-terminal components; the lead resistances are also drawn and their individual effects can be evaluated. First, r_1 and r_8 are

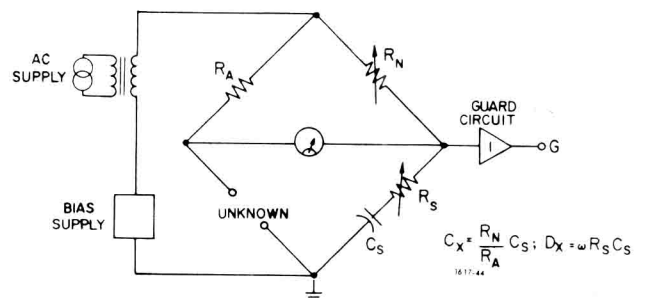

Figure 5-1. The RC bridge used on the five lower capacitance ranges.

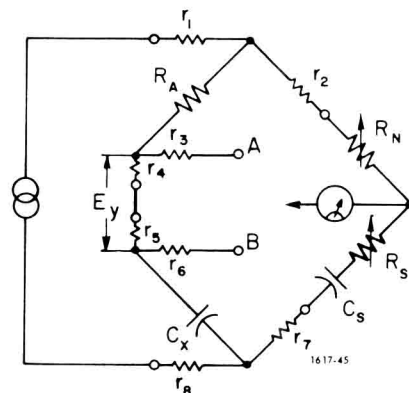

Figure 5-2. The RC bridge circuit where the unknown and the ratio arm resistor are represented as 4-terminal components.

in series with the generator and only reduce the effective applied voltage but do not change the null condition. Then r_2 and r_7 are in series respectively with R_N and R_S-C_S , which have relatively high impedance and, therefore, are little affected; r_3 and r_6 are in series with the detector. The remaining r_4 and r_5 (and their connection) present the main error. Their total impedance may be much higher than the impedance of either C_X or R_A , making the voltage drop across them an important part of the applied voltage.

Tying the detector to point A, places the lead resistance in the C_X arm and introduces an enormous D error; tying it to point B adds the lead resistance to R_A , and the C measurement is erroneous. Moreover, the lead inductance, if placed in series with a very large C_X , would cause a capacitance error even at 120 Hz. Obviously some means of greatly reducing the error is required.

A seemingly natural way to compensate the leads effects would be to divide the voltage from A to B, in the ratio of R_A to the unknown or R_N to the R_S-C_S combination, therefore applying the principle of the Kelvin double bridge (long used for dc resistance measurement) to an ac bridge. This would be done by connecting another pair of arms, similar to the R_N and C_S-R_S arms, from A to B and connecting the detector to the junction of these arms (Figure 5-3).

Corresponding variable components would be ganged to maintain the same ratio in both sets of arms. If the ratios between both pairs of arms were exactly the same, there would be no error, however large the lead impedances might be. Unfortunately, the ability to track with a wirewound rheostat is limited at best by its resolution. In general, tracking to much better than 1% is difficult. When measuring 1 F, 20 mΩ of lead resistance and a tracking accuracy of 1% still produce a C error of over 2%.

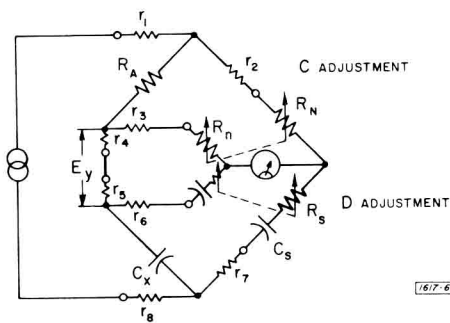

Figure 5-3. A four-terminal capacitance bridge using the Kelvin double-bridge principle. For ac measurement on a complex impedance, two ganged adjustments are necessary.

5.1.4 THE BRIDGE CIRCUIT FOR HIGH CAPACITANCE.

A unique feature of the Type 1617 Capacitance Bridge is the compensation arrangement used to measure high-valued (low-impedance) capacitors, as shown in Figure 5-4.

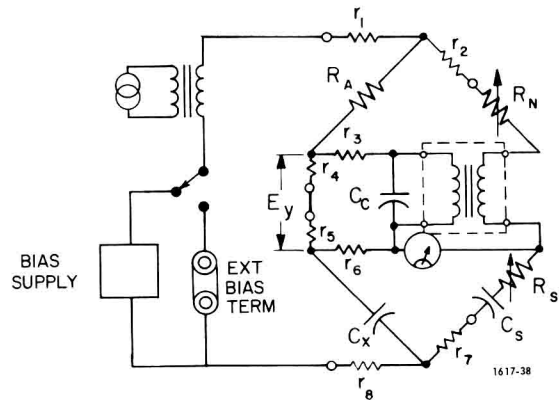

Figure 5-4. The basic circuit of the Type 1617 bridge where a voltage equal to the error voltage, E_y , is placed in the opposite side of the bridge by a tightly coupled transformer.

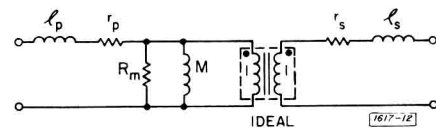

Figure 5-5. Equivalent circuit of the transformer.

The creation of a voltage equal to E_y between the R_N arm and the R_S-C_S arm solves the problem, because the lead error is compensated by the symmetry of the circuit. This is achieved by insertion of a 1:1 transformer. Unfortunately, the transformer, bifilar wound on a high permeability core, is not perfect, as shown by the equivalent circuit of Figure 5-5. C_c is a capacitor placed to "resonate out" some of the effect of the mutual inductance. The coupling coefficient of the transformer differs from unity by only a few parts per million.

The bridge-balance equation yields the following:

$$C_x = \frac{R_N}{R_A} C_S \left[1 + \frac{r_p + r_s + r_3}{R_N} - \frac{(r_4 + r_5) l_p}{R_A M} + \frac{(r_4 + r_5) r_6 C_X (1 - \omega^2 M C_c)}{M} - \frac{(r_4 + r_5) (r_3 + r_p)}{R_M R_A} - D_x \right]$$

$$\left(\frac{(r_4 + r_5) (r_3 + r_6) (1 - \omega^2 M C_c)}{R_A \omega M} - \frac{(r_4 + r_5) \omega l_p}{R_A R_M} + \frac{\omega(l_p + l_s)}{R_N} \right)$$

This form is quite impracticable, but a little examination will simplify the equation greatly. The first error term is taken into account in the calibration of R_N . By construction, the transformer has very small leakage inductance, making the second, sixth, and seventh terms negligible. The addition of C_C reduces the error in the third and fifth terms. The equation becomes:

$$C_x = \frac{R_N}{R_A} C_S \left\{ 1 + \frac{r_4 + r_5}{R_A} \left[\frac{r_6 C_x (1 - \omega^2 M C_C) R_A}{M} - \frac{r_3 + r_p}{R_M} - \frac{D_x (r_3 + r_6) (1 - \omega^2 M C_C)}{\omega M} \right] \right\}$$

Note that the important error terms are not constant but are functions of the changing R_A and C_X , which makes complete compensation impossible.

The use of this scheme gives extremely good results; measurement of 1F, with $r_4 + r_5 = r_6 = 20 \text{ m}\Omega$, gives an error of approximately 0.1%. Therefore, the specification (1% for C) makes allowance for connecting leads of considerable length when large remotely located capacitors are measured.

5.2 GUARD CIRCUIT.

Whenever stray capacitances are an important percentage of the capacitance of the unknown, shielding is necessary to prevent error. The addition of a shield to prevent stray capacitances across the unknown results in an appreciable capacitance created by the shield itself, and a guard point is required to keep these capacitances from affecting the measurement. The guard circuit of the Type 1617 Capacitance Bridge, therefore, advantageously permits remote and 3-terminal measurements (refer to paragraph 3.1.4). It is also useful in that it prevents the internal shields from introducing other stray capacitances.

The junction of the R_N and R_S - C_S arms (point A, Figure 5-6) is usually used as guard point in RC bridges. The capacitance from A to the + UNKNOWN terminal shunts the detector and causes no error. The capacitance from A to ground shunts the R_S - C_S arm but is comparatively so small that it can be neglected. However, the Type 1617 can apply 600 V across the unknown, therefore across the R_S - C_S arm, placing the guard point at a potential of 600 V, a rather undesirable situation.

To avoid this dangerous situation, a unity-gain amplifier is connected between this passive guard point and the actual guard terminal, G, as shown in Figure 5-6. The output of the amplifier is clamped to ground by a rectifier, so that G is never at a high potential,

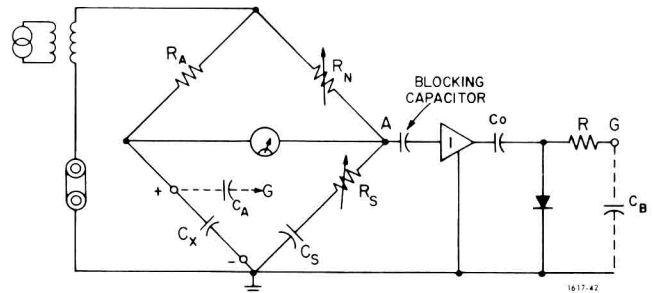

Figure 5-6. The guard circuit with respect to the bridge.

even in case of an accidental short from the guard to the + UNKNOWN terminal.

The performance of the guard circuit is measured by its gain and output impedance. The capacitance from the + UNKNOWN terminal to G (C_A) in effect shunts the unknown, but with a value reduced by a factor of 1-K. The gain, K, of the unity amplifier is approximately 0.999, so that 1000 pF to GUARD is equivalent to approximately 1 pF across C_x . Capacitance from G to ground (C_B) has no effect by itself, but it does reduce the effectiveness of the GUARD because of the limited output impedance of the amplifier. The effective capacitance shunting the unknown is approximately:

$$C_A \left(1 - K \frac{C_o}{C_o + C_B} \right) \approx C_A (1 - K) + \frac{C_A C_B}{C_o}$$

where C_O is the output capacitance of the guard circuit (10 μF).

The resistor in series with the guard protects the grounding rectifier from excessive current and has a lower impedance than the 10 μF output capacitor at 120 Hz.

A shorted GUARD terminal does not damage the guard circuit, but impairs the accuracy of the bridge.

5.3 THE INTERNAL GENERATOR.

The generator can be considered a selective filter operating on the rectified line voltage, or an oscillator synchronized to the line. The former is probably more accurate because the circuit would not oscillate when powered by a supply having low ripple.

The filter circuit is a simple Wien-bridge feedback arrangement, with two arms formed by the RC-Wien network, and the other two by the level-adjustment divider. The line voltage is full-wave rectified, to supply a signal rich in the 120-Hz component, and the filter capacitor is purposefully small so that a great amount of this signal reaches the input stage by means of the bias resistor (R217).

The compound (Darlington) output stage drives the primary of the input transformer at a level of about 5 V, rms. This transformer isolates the generator circuit from the capacitance bridge, which may have 600 Vdc

applied to it. It also provides several output voltages by means of secondary taps selected by the GEN LEVEL switch.

5.4 INTERNAL DETECTOR.

The detector for this bridge is ungrounded and yet powered by the line, even though the bridge signal is a line harmonic. This makes the limitation of hum pickup both critical and difficult. Extensive shielding and guarding, both in the transformer and the leads, keeps the pickup negligible and controls the stray capacitances to ground.

The detector circuit is a straight-forward selective-amplifier circuit. The input stage has a high input impedance to avoid loading the bridge on the lower ranges (when it presents a very high impedance to the detector). The selective stage is made "flat" by ungrounding the twin-T selective circuit, when the function switch is in the EXT GEN position. The output stages form an amplifier capable of high compression, accomplished by a diode network in the feedback voltage divider. This compression gives a "semi-logarithmic" characteristic to the meter response, allowing balances over a wide dynamic range without repeated adjustments of the DETECTOR SENSITIVITY potentiometer (R443). No connection to the detector output is available on the panel of the Type 1617 Capacitance Bridge because it is very rarely necessary. However, the use of a shielded transformer (GR Type 578-A or -B) connected to the detector board (Figure 5-7) will make this output readily usable if it is required.

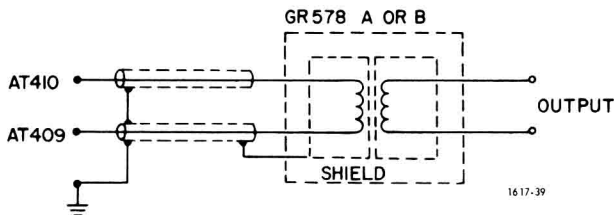

Figure 5-7. Connections to the detector etched board to make the detector output available.

5.5 THE BIAS VOLTAGE SUPPLY.

The bias-voltage supply is connected in series with the input transformer and bridge as shown in Figure 5-8, so that the full dc is applied to the capacitor being measured. The ac signal is applied to the bridge in series with the dc supply, which therefore must present a low ac impedance at its output to avoid a serious reduction of the ac voltage applied to the bridge when large capacitors are measured. This requirement is met by placing a capacitor at the output of the dc supply to present a low impedance to the ac signal. This capacitor must be able to charge to the full bias voltage. A dif-

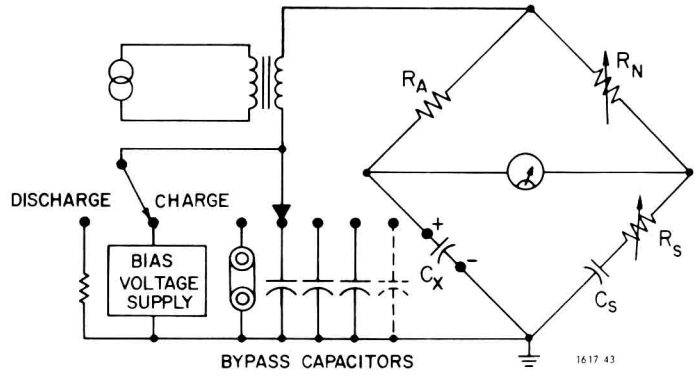

Figure 5-8. The bias-voltage supply and its battery of bypass capacitors.

ferent capacitor, offering the lowest impedance at the required voltage, is switched in as the bias voltage range is changed (giving optimum conditions at all times).

The high-voltage supply itself is a series-regulator circuit, using a high-voltage vacuum tube as the series element and transistors for additional loop gain. The supply is adjustable both continuously and in steps. The continuous adjustment is accomplished with an adjustable reference sampled by one side of the differential input stage. The other input samples the voltage across a fixed resistor in series with the switched range resistors.

On the 2-V range, the sampling resistor (R214) is tied directly to ground and the adjustment span is set for 2 V, maximum, by means of R208. Thus, 1 mA flows in the sampling resistor for a full-scale setting. This condition is still met when resistors are placed between the sampling resistor and ground, making the maximum output voltage (in volts) for each range equal to the value of the total resistance (in kilohms) added, plus 2 V.

It should be noted that all the regulator circuitry may be off ground by the full bias voltage and, therefore, the bias should be set to a low voltage range when this circuit is to be serviced.

5.6 ORTHONULL.®

Orthonull is a mechanical device that improves the bridge balance convergence when high-D capacitors are measured. Ordinarily, balances with such components are tedious and often impossible, due to the "sliding null" resulting from the interdependence of the two adjustments. Rapid balances are possible with Orthonull, which does not affect the electrical balance conditions but which does help avoid false nulls, improving bridge accuracy for high-D measurements. The unbalance voltage of the bridge, that is the voltage existing across the detector before balance is achieved, can be expressed as follows:

$$E_O = E_{in} \frac{Z_2 Z_4 - Z_1 Z_3}{(Z_1 + Z_2)(Z_3 + Z_4)} = E_{in} \frac{Z_2 - \frac{Z_1 Z_3}{Z_4}}{(Z_1 + Z_2)(1 + \frac{Z_3}{Z_4})}$$

where Z_1, Z_2, Z_3, Z_4 are the impedances of the four arms.

For the bridge of Figure 5-1:

$$E_O = \frac{R_X + \frac{1}{j\omega C_X} - \frac{R_A R_S}{R_N} + \frac{1}{j\omega C_S R_N}}{\text{Denominator}}$$

We will assume that the denominator is more or less constant in the region of the null. The numerator is the difference between the unknown impedance $R_X + \frac{1}{j\omega C_X}$ and what can be called the "bridge impedance". The bridge output is proportional to this difference, which is the distance between them on the complete plane. To balance the bridge, the bridge impedance is varied by adjustment of R_N (the C dial) and R_S (the D dial), until it equals the unknown impedance. An adjustment of R_S varies only the real part of the bridge impedance, whereas the adjustment of R_N varies both parts, and is therefore a multiplier of the bridge impedance. Thus, adjustment of R_S moves the bridge impedance horizontally on the complex plane, while adjustment of R_N moves it radially (see Figure 5-9). Each control is adjusted for a minimum voltage.

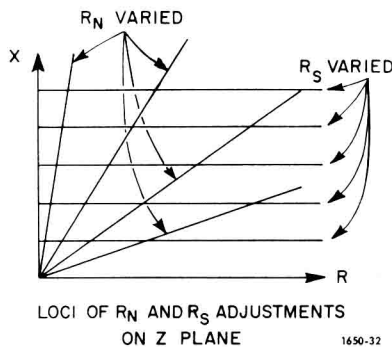

Figure 5-9. Loci of R_N and R_S adjustments on the Z plane.

When $X \gg R$ (i.e., when D is low) these two adjustments are almost orthogonal, and rapid convergence is possible. When D is high, however, the adjustment becomes more parallel and convergence is slow, causing a "sliding null", as shown in Figure 5-10, where $D=2$. With higher D 's, convergence is even slower.

The Orthonull device makes the two adjustments orthogonal by nonreciprocally ganging R_N and R_S . From the equation, it is apparent that if R_S/R_N remained constant as R_N was varied, only the imaginary part of the bridge impedance would change. But when

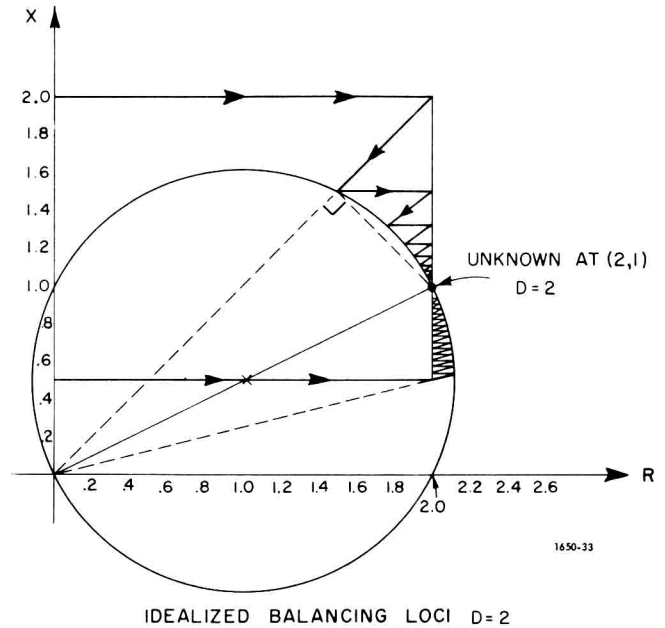

Figure 5-10. Loci of "sliding null" balances.

R_S is adjusted, R_N must not move, to vary only the real part. The solution is a simple friction clutch to permit nonreciprocal action. Both the inherent difference in friction of the two rheostats and the pulley ratio favor torque transmission in the desired direction.

The ratio R_S/R_N must be constant for variation in R_N for any initial settings of R_N and R_S , since R_S may be moved independently of R_N . This requires rheostats with exponential characteristics (and logarithmic dials). The D rheostat is a 54-dB exponential potentiometer. The C rheostat is exponential in the dial range from 1 to 11, and linear below 1. Thus, for correct Orthonull action, the C dial must always be set in the range above 1.

The advantage of Orthonull is illustrated in Figure 5-11, which is a plot of the number of adjustments necessary for a balance. Not only does the Orthonull reduce the number of balances, but it permits 1% measurements that would otherwise be impossible with D above 3, due to the finite resolution of the D rheostat. This finite resolution causes the meter indication to vary in jumps when Orthonull is used at D 's above 3. However, by selection of the best null, 1% accuracy is possible with D 's of more than 5 and 20% with D 's of 10.

5.7 THREE-AND-FOUR-TERMINAL MEASUREMENTS.

5.7.1 GENERAL.

Stray impedances - the plague of precise metrology - are of two kinds: shunt and series impedances. Fortunately, in the case of capacitance measurements, they are rarely both important at the same time. The

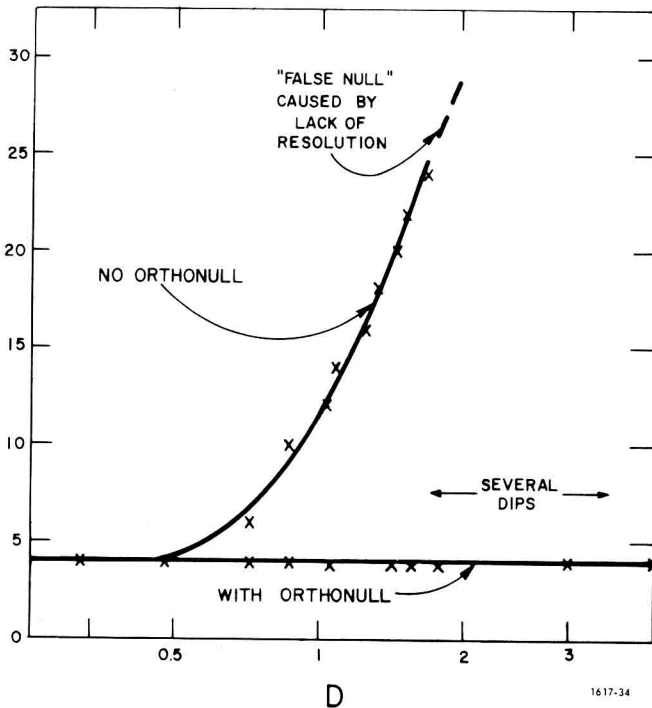

Figure 5-11. Number of adjustments to obtain balance versus D .

shunt impedances introduce error in low-capacitance measurements and are corrected by 3-terminal measurements. The series impedances are important in the measurement of high capacitance (low impedance) and necessitate 4-terminal measurements.

5.7.2 THREE-TERMINAL MEASUREMENTS.

The shielding of a low-valued capacitor prevents the direct shunting of the unknown by a stray capacitance. However, the shield is, in effect, a third terminal and there may be appreciable capacitance from the terminals of the unknown to the shield (Figure 5-12).

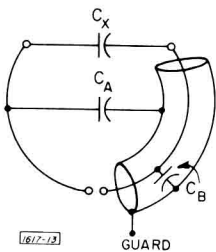

Figure 5-12. Measurement of a capacitor C_x with a shielded lead and the resulting stray capacitances. The shield prevents stray capacitance from being set up directly across the unknown.

The object is to eliminate C_A and C_B from the direct measurements of C_x . This can be accomplished by measurement of short-circuit transfer admittance, I_o/E_{in} , of the circuit of Figure 5-13.

If the source and the ammeter have zero impedance, the measurement is independent of C_A and C_B and:

$$y_{21} = I_o/E_{in} = j\omega C_x$$

The Type 1617 Capacitance Bridge uses an active guard circuit to achieve the same result (refer to paragraph 5.2).

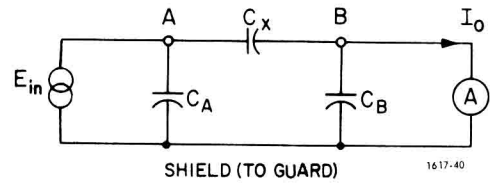

Figure 5-13. Elimination of the effect of the stray capacitances C_A and C_B by a short-circuit transfer-admittance measurement.

5.7.3 FOUR-TERMINAL MEASUREMENTS.

A high-valued capacitor is little affected by a shunt stray capacitance but, because of its low impedance, it is very much affected by a series stray impedance (such as lead resistance). Here, a measurement of transfer impedance, E_o/I_{in} , will eliminate the effect of the leads (Figure 5-14) if both the source and the voltmeter have infinite impedances; $E_o/I_{in} = Z_{21}$ is exactly the impedance from A to A', i.e., $1/j\omega C_x$. This method shows quite clearly why in a 4-terminal component, two terminals (C, C') are usually labelled the "current" terminals and two, (P, P') the "potential" terminals.

The Type 1617 uses a similar, if not exactly identical method of measurement. Its two outer connectors can be considered "current terminals" and the inner connectors "potential terminals".

It is interesting to note that there are some applications where both series and shunt stray impedances affect the unknown enough to require that both 3- and 4-terminal techniques be used at the same time. Examples are: very high precision measurements on standard capacitors of medium value, high-frequency measurements on capacitors and measurements on remotely located components (refer to paragraph 4.5.1).

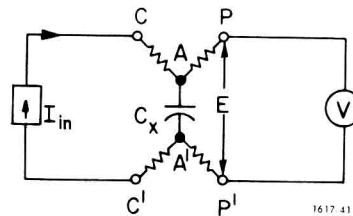

Figure 5-14. Elimination of the lead impedance by a transfer-impedance measurement.

¹R.D. Cutkosky, "Four Terminal Pair Networks as Precision Pair Networks," IEEE Transactions on Communication and Electronics, #70, January 1962, page 19.

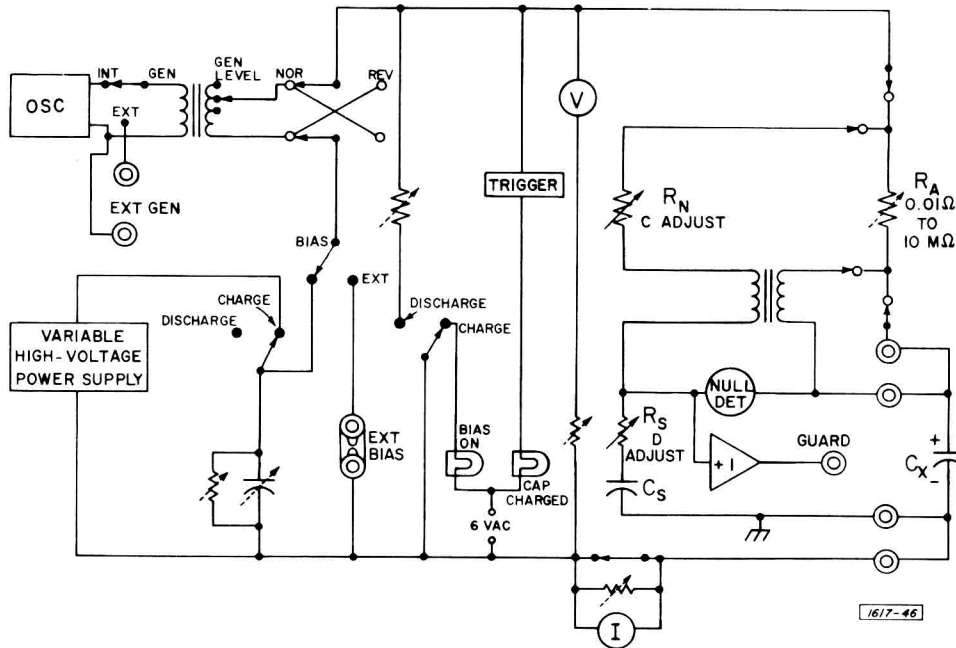

Figure 5-15. Simplified schematic of Type 1617 Capacitance Bridge showing three measurement modes: null, voltage, and current.

5.8 GENERAL.

The interrelationship of the several circuits that make up the Type 1617 Capacitance Bridge will become

more apparent by reference to Figure 5-15, a simplified schematic description of the complete instrument. Comprehensive circuit details are presented in the full schematic drawings shown in Section 6.

Service and Maintenance—Section 6

WARNING

High voltages, constituting potentially lethal shock hazards, exist in the circuitry inside the case of this bridge.

If troubleshooting is necessary, it should be performed by qualified personnel familiar with the hazards inherent in high-voltage circuits.

6.1 WARRANTY.

We warrant that each new instrument manufactured and sold by us is free from defects in material and workmanship, and that, properly used, it will perform in full accordance with applicable specifications.

6.2 SERVICE.

The warranty stated above attests the quality of materials and workmanship in our products. When difficulties do occur, our service engineers will assist in any way possible. If the difficulty cannot be eliminated by use of the following service instructions, please write or phone our Service Department (see rear cover), giving full information of the trouble and of steps taken to remedy it. Be sure to mention the serial and type numbers of the instrument.

Before returning an instrument to General Radio for service, please write to our Service Department or nearest District Office, requesting a "Returned Material Tag". Use of this tag will ensure proper handling and identification. For instruments not covered by the warranty, a purchase order should be forwarded to avoid unnecessary delay.

6.3 TROUBLE ANALYSIS.

6.3.1 PRELIMINARY CHECKS.

If satisfactory balances are difficult or impossible to obtain, make the following external checks first.

1. Is the instrument connected to the line?
2. Is the power on?
3. Is the unknown connected correctly?
4. Are all the panel controls set properly?
5. Are all the shorting links in place? For 2- and 3-terminal measurements, link the two positive terminals and link the two negative terminals. The link on the EXT BIAS terminals should always be connected if the terminals are not in use.
6. Is the unknown what it is thought to be? Try measuring a known component.
7. Is the D so high that Orthonull should be used?
8. Is the SENSITIVITY control on?

6.3.2 TROUBLE ANALYSIS.

The Type 1617 Capacitance Bridge is self-contained and incorporates six major circuits, the generator, the detector, the guard and trigger, the bias supply, the meter and the bridge; one or several of these may become defective.

A component is connected and balance is attempted.

1. NOISY OR ERRATIC BALANCE. This may be due to surface contamination of the wirewound C and D control rheostats. Contamination can form if the bridge is left idle for an extended period and can be eliminated by rotating the controls several times.

2. WRONG VOLTAGE INDICATION.

If the bias was applied and it appears that a wrong result is obtained, a d-c voltmeter across the unknown will read the actual value of the dc bias applied. If this is not what was intended, or shown by the meter, the internal supply is faulty, proceed to paragraph 6.4.3 (see also paragraph 3.4).

3. CAPACITANCE MEASUREMENT ERROR. If the measurement was guarded (3-terminal) and it appears that the guard does not accomplish its purpose, proceed to paragraph 6.4.4. The proper functioning of the guard when measuring a small capacitor ($<0.01 \mu\text{F}$) is checked by connecting a capacitor (around 1000 pF) from the guard to the positive terminal. If the reading is not appreciably changed, the guard is operative. Loss of proper guard action can cause errors in the highest as well as the lowest C ranges. Check guard if error appears on those ranges (see above).

Finally, if the balance obtained is known to be erroneous, some bridge circuit component is faulty, (refer to paragraph 6.4.6).

4. NO DEFLECTION. A process of elimination will localize the trouble.

a. Connect an external generator (120 Hz giving 5 V, rms); the Types 1310 or 1311 oscillators are well suited for the purpose. If balance is obtainable, the internal generator is faulty (refer to paragraph 6.4.1). If nothing happens, proceed below.

b. Detector and Meter Check—Keep the external generator connected and set controls as follows:

MULTIPLIER switch to 100 pF.

C Dial to 10.

D Dial to 1.

GEN LEVEL MAX VOLTS to 0.2.

DETECTOR SENSITIVITY fully clockwise.

c. Disconnect the link at the two positive UNKNOWN terminals, thus isolating the detector input and connect an oscillator between AT401* and AT402. A signal from this oscillator of approximately 0.5 V at 120 Hz should drive the meter full scale. This meter should peak at 120 Hz $\pm 2\%$.

If the check is negative, either the detector or the meter is faulty. Connect an external indicator (earphones, scope . . .) to the detector output (refer to paragraph 5.4 and Figure 5-7) and again look for this signal. If it is there, the meter is faulty; if it is not the detector is to be repaired. Proceed to paragraph 6.4.2.

*The anchor terminals (AT) are the most accessible test points, they are on one side of the etched boards (see Figures 6-7 through 6-9). The AT is usually omitted on the board. All anchor terminals with the same first digit (4 in AT401) are on the same board.

5. EXCESSIVE DISCHARGE TIME. On the high-voltage ranges, high-capacitance ranges, and combinations of high capacitance/high voltage, where lethal charges may be present at the UNKNOWN terminals, the circuit is designed so as to discharge the capacitor being measured very quickly. Therefore, when the BIAS CHARGE-DISCHARGE control is switched to DISCHARGE, the CAPACITOR CHARGED lamp should go out almost immediately.

When measuring high-value capacitors at low voltage, it may take up to several seconds to drop the bias voltage below 1 volt and therefore have the lamp go out, but this is not a dangerous condition.

If the time required for discharge is excessive, it may indicate a burned-out discharge resistor (R178 through R181), or a faulty discharge switch (S106).

6.4 DETAIL TROUBLE ANALYSIS (Figure 6-1).

6.4.1 GENERATOR.

Set the function switch to INT 120 C, the MULTIPLIER switch to 1 μF , and connect a scope across R115 (on switch S102). The waveform (120 Hz) should be free of distortion and have an amplitude equal to the setting of the GEN LEVEL MAX VOLTS switch (S105). If the level is incorrect adjust R222. (Too high a level causes waveform distortion). If some, but not all three, voltages are obtained, check switch S105 for proper contact and check the secondary taps of T101 for open-circuit indications. If the correct ac output cannot be obtained, check the dc levels within the generator circuit (Table 6-6) and the ac voltages at transformer output T501 (Table 6-1).

Table 6-1

Transformer Secondary Voltages (T501) With 115 V Into The Primary (Figures 6-2 and 6-10)	
Pins	Voltage (rms)
5-6	9.6 V
7-8	4.8 V
8-9	15.3 V
10-11	110 V
11-12	155 V
13-14	110 V
14-15	6.0 V
17-18	15.0 V

6.4.2 DETECTOR.

With 0.5 mV applied (paragraph 6.3.2), Table 6-2 shows typical waveforms and amplitudes. Check the dc voltages as in Table 6-6.

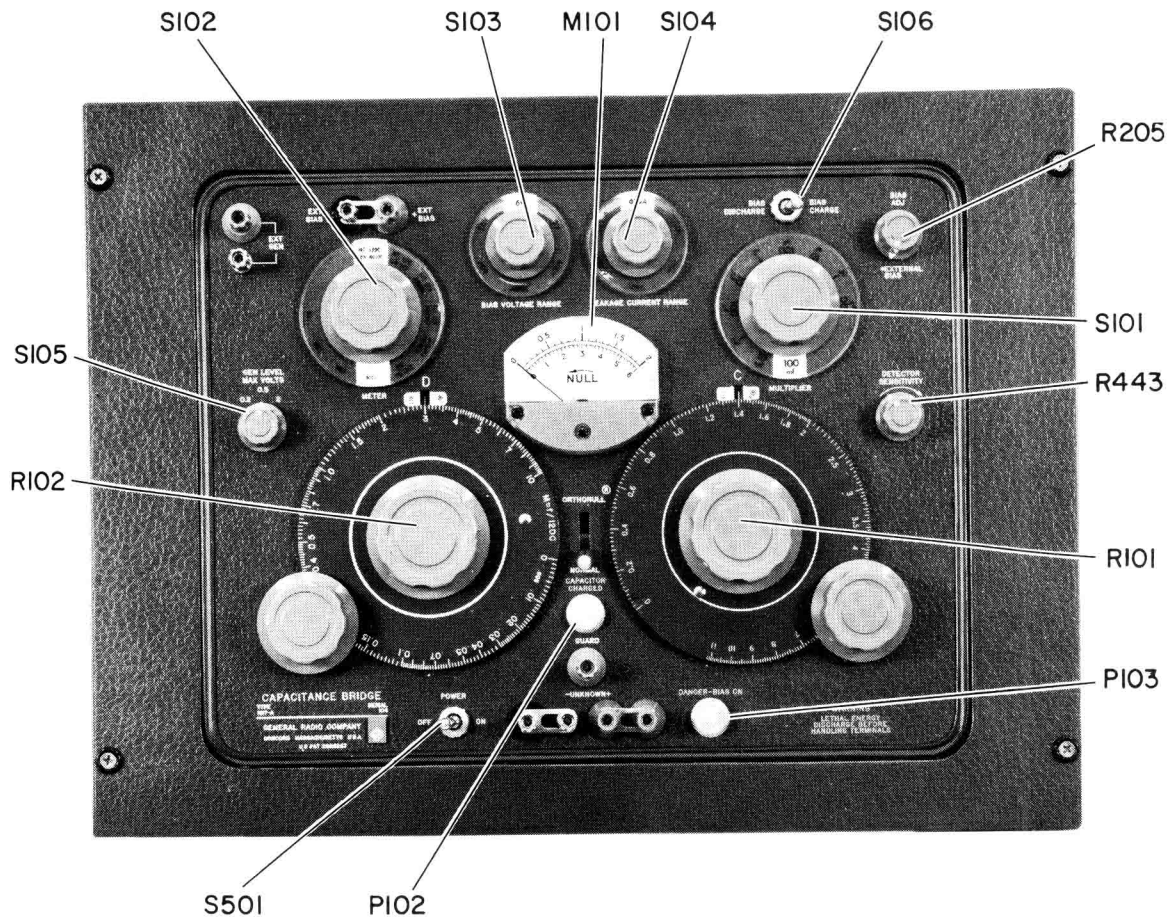
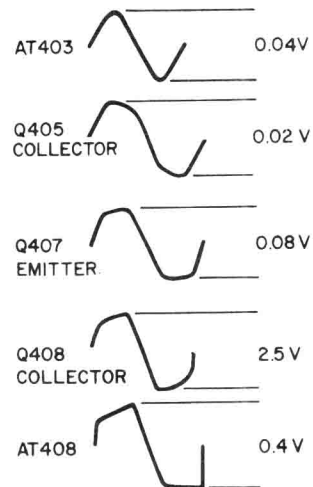

Figure 6-1. Front view of the Type 1617 Capacitance Bridge.

AT403	~0.04 V
Coll., Q405	~0.02 V
Emitt., Q407	~0.8 V
Coll., Q408	~2.5 V
AT408	~0.4 V



6.4.3 INTERNAL BIAS SUPPLY.

To check the internal bias supply:

a. If the measured voltage is correct on all ranges but the indication of the Type 1617 meter differs from the measured value –

Adjust R183 (VOLTAGE RANGE switch on 2V).

Check the meter-range resistors (R158 through R163) for proper value (on second deck of S103).

b. If the measured voltage is wrong on only some ranges, check the values of the resistors of the first deck of S103 and the switch contacts associated with these resistors.

c. The highest voltage in each range is not equal to the value indicated on the switch legend – adjust R208. If not sufficient, check all dc levels as in Table 6-6.

d. If the dc bias voltage varies with line voltage, check the 7239 tube and the transistors of the circuit (Table 6-6).

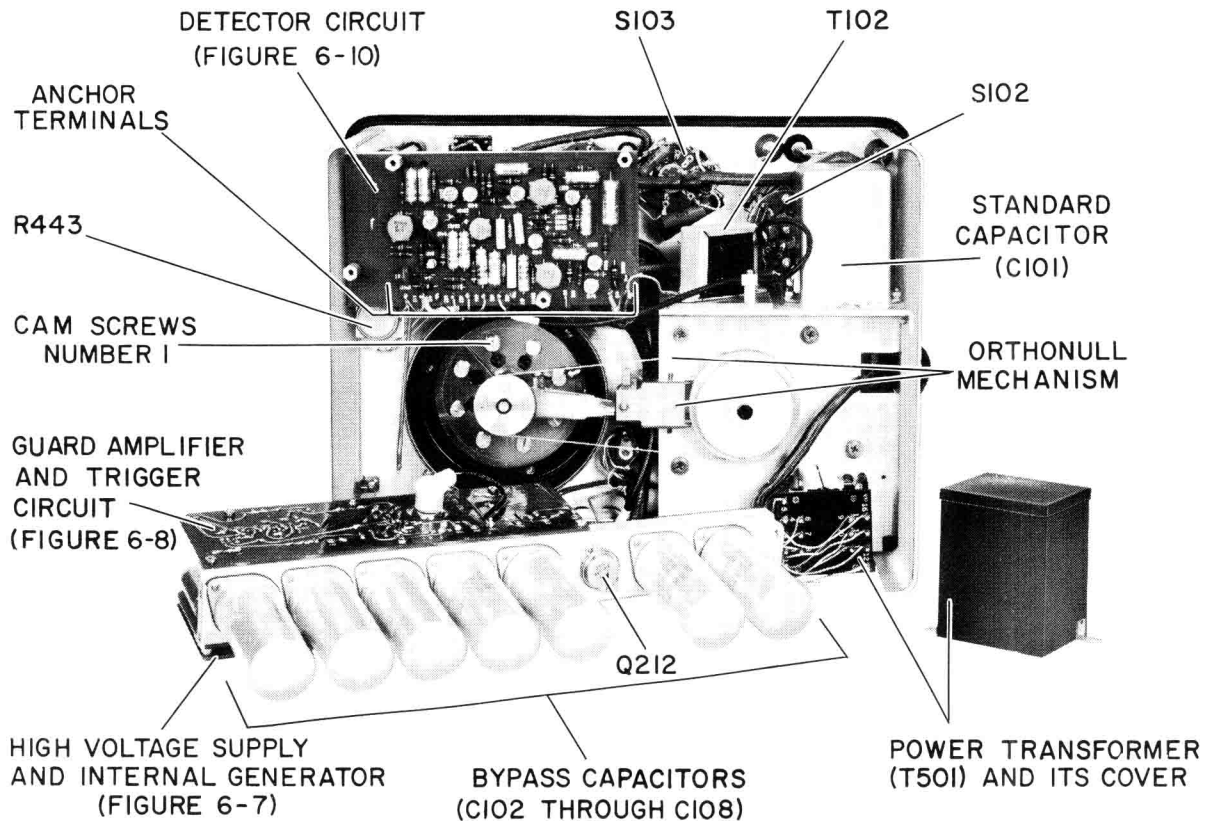

Figure 6-2. Rear interior view of the Type 1617 Capacitance Bridge.

6.4.4 GUARD CIRCUIT.

Observe that:

- The shield around the positive UNKNOWN terminals, and all the shielded cables from UNKNOWN and GUARD terminals are properly guarded.
- The lead connecting the unknown to the positive terminal is properly shielded.
- The guard-circuit amplifier is functioning. To do this, set the function switch to INT 120C, the MULTIPLIER switch to 1 μ F, the C dial to 0, and switch the bias off. Then the ac voltage measured between the GUARD terminal and ground should be the same as that measured from the positive unknown terminal to ground.

A negative check is caused by a faulty amplifier or some shorted guard point. To find out if the amplifier is operating, check the guard output at AT307, with the white-yellow-brown lead disconnected. If the amplifier is not functioning properly check the dc voltages in Table 6-6.

6.4.5 TRIGGER.

The trigger circuit should operate so that it fires the CAPACITOR CHARGED lamp when a bias of 0.5 to 1.0 volt is applied to the UNKNOWN TERMINALS. Check the dc voltages if it does not (Table 6-6).

6.4.6 BRIDGE.

For an unknown ($R_x + j\omega C_x$), the balance equations of the bridge are:

$$R_x = \frac{R_A}{R_N} R_s \text{ and } C_x = \frac{R_N}{R_A} C_s$$

where R_A and C_s are fixed components.

R_N and R_s are rheostats (C and D dials) and all four components have to be within tolerance.

Check the calibration of the bridge by making the measurements of Table 6-3. Six standard capacitors are shown although any range can be checked using any capacitor of known value which falls within that range. Suitable capacitors include the Type 1409 Standard Capacitor, Type 1423-A Precision Decade Capacitor, and Type 1424-A and 1425-A Standard Decade Capacitors.

If large standard capacitors are not available, the higher capacitance ranges may be checked by direct measurement of the ratio-arm resistors, for these are the only components in the bridge that change with the range. These resistors (R103 through R112) may be measured with a dc bridge. A Kelvin, four-terminal bridge is necessary for the two highest ranges, and preferable for the next two lower ones, to avoid errors due to lead resistance.

Table 6-3

Bridge Calibration Check					
Measurement	Standard Value	Connection No Terminals	MULTIPLIER setting	C setting $\pm 1\%$	Faulty R_A
a	100 pF	3*	100 pF	1	R112
b	10 MF	3	1 nF	10	R111
c	10 nF	3	10 nF	1	R110
d	1 μ F	3	100 nF	10	R109
e	1 μ F	3	1 μ F	1	R108
f	100 μ F	4**	10 μ F	10	R107
g	100 μ F	4	100 μ F	1	R106
h	100 μ F	4	1 mF	0.1	R105
i	10 mF	4	1 mF	10	R105
j	10 mF	4	10 mF	1	R104
k	100 mF	4	100 mF	1	R103

*three-terminal measurement (two-lead cable)
**four-terminal measurement (three-lead cable).

The main circuit diagram, Figure 6-13, indicates the terminals on S101 that should be used for connection. (The highest capacitance range uses the lowest-valued resistors e.g., R103.) The four highest ranges use a four-terminal connection in the bridge. Each resistor should be within 0.25% of its nominal value. The range switch should be set to a range other than that being measured to avoid error. The side pan of the instrument will have to be removed for access to the higher-value units.

The results of the measurements in Table 6-3 indicate:

1. When only one measurement is in error the corresponding faulty component is listed in Table 6-3.
2. When all measurements at either 1 or 10 on the C dial are in error, the C rheostat is in error at 1 or 10.
3. When all measurements are in error by the same percentage (value), the standard capacitor (C101) is faulty.
4. When measurements are in error by the same arc of displacement, whether at 0.1 or 10 on the C dial (measurement f and h), the dial has slipped and is easily realigned.
5. When all measurements and all fixed components of the bridge are within tolerance, if the C rheostat is correct on the 1 and 10 setting, it may still be incorrect between 1 and 10 (refer to paragraph 6.5.2).

6.5 CALIBRATION PROCEDURE.

The few internal adjustments are factory set and normally do not require readjustment. Procedures for recalibration are included here but should be used only when the operator is reasonably certain that it is necessary.

6.5.1 GENERAL.

An impedance bridge with an accuracy of 0.25% or better is necessary; the Types 1608 and 1656 Impedance Bridges can be used.

If the trouble is narrowed to the ratio arm resistors (R_A) or the standard capacitor, ascertain that they are within tolerances ($\pm 0.25\%$ for R_A , $\pm 0.25\%$ for C_S); change any defective unit.

The C rheostat can be recalibrated (paragraph 6.5.3); the D rheostat is fixed and only slipping of the dial can be corrected (paragraph 6.5.3); finally the orthonull operation can be checked (paragraph 6.5.4).

6.5.2 C CALIBRATION.

If it has been found that the C rheostat is faulty, it can be readjusted by means of its justifying mechanism. Two methods can be used to do so.

Direct Resistance Measurement. The C rheostat mechanical justifying mechanism consists of eight cam screws located on the rear of the C rheostat (see Figure 6-2), numbered from 1 to 8 in a clockwise direction from the slit on the cam plate. They can be adjusted by setting them for the proper resistances as indicated in Table 6-4. To reach the rheostat, remove two screws on each side of the inner plates, unsolder the connecting wire, and swing down the battery of capacitors.

NOTE

If these cam screws seem to be completely out of adjustment, preset cam screw 1 four turns from fully clockwise and preset the remaining screws two turns from fully clockwise, before attempting the adjustment procedure.

Table 6-4

C Dial Calibration Adjustments (Figure 6-2)			
Dial Reading	Resistance* Ohms	Tolerance	Adjust Cam Screw
0.1	200	190 to 210 ±1/4 division	1
0.6	1,200	1190 to 1210 ±1/4 division	2
1.3	2,600	2574 to 2626 (+1/2%)	3
2.2	4,400	4356 to 4444 (+1/2%)	4
3.6	7,200	7128 to 7272 (+1/2%)	5
5.5	11,000	10,890 to 11,110 (+1/2%)	6
8.0	16,000	15,840 to 16,160 (+1/2%)	7
11.0	22,000	21,780 to 22,220 (+1/2%)	8

If, after adjustment, the cam plate is too high or too low, reposition the C dial on its shaft and repeat the cam-screw adjustment procedure.

Adjustment From A Measurement. A somewhat easier method (because it does not require a resistance bridge) consists in connecting a variable capacitor (like the GR 1423 or 1413 Precision Capacitors) to the bridge, and making the balance setting of the C dial and the known value of C, agree by adjustment of the proper cam screw.

Proceed as follows:

- Connect the variable standard of value S to the bridge UNKNOWN TERMINALS.
- Set the MULTIPLIER on (M) and the C Dial on (C), so as to have $S = (M) \times (C)$
- Balance the bridge with the D dial and the cam screw (s) closest to the rheostat arm.
- Change S and C and repeat the procedure until all cam screws are adjusted.

NOTE

It is advantageous to choose the settings of the C dial given in Table 6-4, because the cam screw to be adjusted is then directly under the rheostat arm.

6.5.3 D DIAL CHECK.

To check the calibration of the D dial proceed as follows:

- Set the MULTIPLIER switch to 100 nF.
- Set the C dial on 5.
- Connect to the bridge a 1.0 μF Standard Capacitor*, such as GR 1409 in series with a decade resistance box, such as a GR 1433 (Figure 6-3).

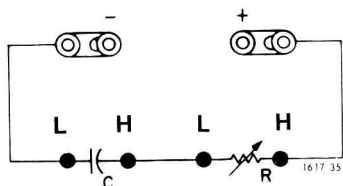

Figure 6-3. Connections for R and C in the D-dial check.

d. Set the resistance according to Table 6-5 and observe that the bridge balances for the corresponding D setting.

If the first and last measurements are in error by the same arc or displacement of the dial, then the dial has slipped. If the errors are random, the rheostat is faulty (it cannot be adjusted and has to be changed).

Table 6-5 Resistance Settings for D Check When C=1μF		
D* Setting	Resistance Setting	
	100 Hz	120 Hz
0.1	159 Ω	133 Ω
1	1.592 kΩ	1.326 kΩ
3	4.775 kΩ	3.979 kΩ
5	7.958 kΩ	6.631 kΩ
10	15.92 kΩ	13.26 kΩ

*Specified accuracy ± .001 ± 2%

6.5.4 ORTHONULL OPERATION.

With the lever in the NORMAL position, the C and D dials must operate independently of each other.

With the lever in the ORTHONULL position, the C dial must move the D dial but the D dial must not move the C dial; if performance is different and —

- D dial moves C dial:

ORTHONULL lever-spring tension is excessive. Turn the nut on the spade-lug counterclockwise to reduce tension.

- C dial doesn't move D dial:

a. ORTHONULL lever-spring tension is insufficient. Turn the nut on the spade-lug clockwise to increase tension.

b. Lever spring is broken or otherwise defective.

c. Drive cable between C dial and D dial is broken or off the pulley.

*Actually any combination of C and R can be used. $D = \omega RC$ has to check with the D setting (within specifications).

Replace the ORTHONULL drive cable as follows (see Figure 6-4):

a. Insert the cable ends through slots 1 and 2 of the D pulley and attach the eyelets to the springs.

NOTE

The cable is attached only to the D pulley at this time.

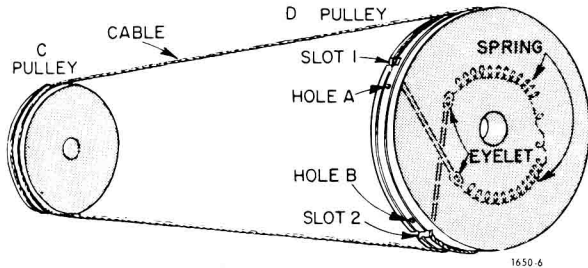

Figure 6-4. Replacement of the Orthonull drive cable.

b. Pull the cable until the eyelets are visible through holes A and B. Insert a pin or small nail through the holes into the respective cable eyelet and release the cable. The pins hold the springs expanded to allow the cable to be threaded around the C pulley.

c. Set the C dial to 1.8. Thread the cable from slot 1, around the D pulley in the groove nearest the panel and then around the C dial in the second groove from the panel.

d. Continue the cable around the C pulley until it emerges from the third groove from the panel and return it to the D dial.

e. The cable is now completely threaded and the pins can be removed from holes A and B.

6.6 FLIP-TILT CABINET.

Figure 6-5 shows the operation of the flip-tilt cabinet and Figure 6-6 shows details of the pivoting part of the flip-tilt.

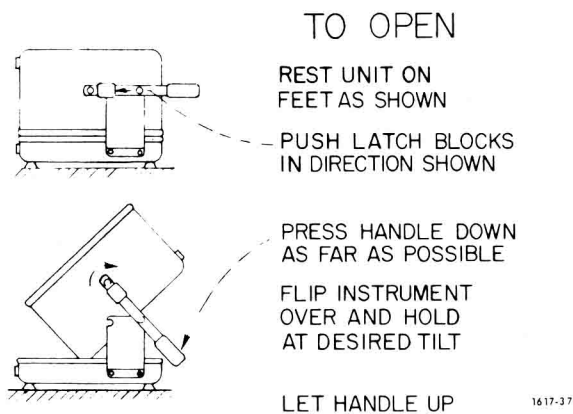

Figure 6-5. Operation of the flip-tilt cabinet.

6.7 REPAIR AND REPLACEMENT.

Defective parts indicated by the trouble-analysis procedures should be repaired or replaced. As an aid in the location of detail parts on the bridge, the etched-circuit boards used are shown in Figures 6-7, 6-8 and 6-10. Figures 6-9, 6-11 and 6-13 contain the complete wiring schematic drawings for the instrument. Figure 6-12 is a switch wiring diagram for front-panel controls.

Reference designators used in all the figures are the same as those used in the parts list that follows.

6.8 MINIMUM PERFORMANCE STANDARDS

The following procedures for checking capacitance and dissipation-factor measurement accuracy of the GR 1617 are recommended for acceptance and periodic tests. There are four basic tests:

1. Capacitance Dial Calibration (see 6.8.2).
2. Capacitance-Range Accuracy (see 6.8.3).
3. Dissipation-Factor Dial Calibration (see 6.8.4).
4. Dissipation-Factor Accuracy On All Ranges (see 6.8.5).

6.8.1 EQUIPMENT REQUIRED

To make the recommended tests the following equipment is necessary:

1. A capacitance decade with range of 1 μ F in steps of .01 μ F and accuracy of 0.1% or better.
2. A resistance decade with a range of 100 k Ω , steps of 1 Ω , and accuracy of 0.1% or better.
3. Capacitance standards or decades with values from 100 pF to 1 F with accuracy of 1/4% or better.

Table 6-7 lists recommended equipment which is fully specified in the appendix.

6.8.2 CAPACITANCE-DIAL CALIBRATION

Set the 1617 MULTIPLIER switch to the x100 nF range and connect the decade capacitor. If the GR 1413 is used, the shield of the high terminal should be connected to the 1617 GUARD terminal. A GR 1423 can be used

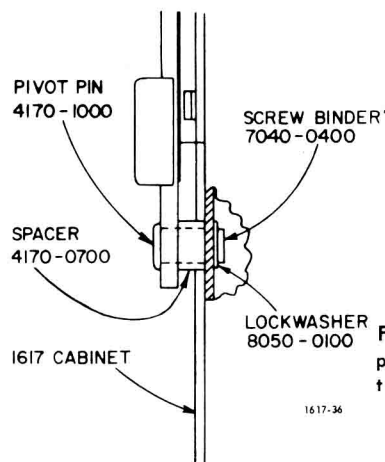

Figure 6-6. Details of the pivot assembly of the flip-tilt cabinet.

Table 6-6

DC Voltages

Test Conditions:

GEN LEVEL MAX VOLTS = 0.5
 INT. 120 C GEN NORM
 BIAS VOLTAGE RANGE = 2 V
 LEAKAGE CURRENT RANGE = 60 μ A
 BIAS CHARGE switch on
 BIAS ADJ control fully CW
 DETECTOR SENS control fully CCW
 MULTIPLIER = 1 μ F
 C DIAL = 0
 D DIAL = 0
 J101 tied to J102, J103 tied to J104

All voltages to chassis ground unless otherwise stated.

High Voltage Supply (Figures 6-7 and 6-9)

V201
 Pin #1 -5.80 V
 Pin #2 2.35 V
 Pin #6 92.0 V

AT205 2V
 AT205 to AT206 2V on all ranges

	<i>Emitter</i>	<i>Collector</i>
Q201	-11.0 V	-5.80 V
Q202	0.645 V	-11.0 V
Q203	0.645 V	-10.5 V
AT207	0.007 V	AT211 -18.2
AT208	0.007 V	AT301 142 V
AT209	-15.5	AT303 142 V
AT210	-15.5	AT304 300 V

Generator (Figures 6-7 and 6-9)

	<i>Emitter</i>	<i>Collector</i>
Q204	1.20 V	8.35 V
Q205	8.50 V	0.910 V
Q212	8.70 V	0.910 V
AT201	4.5 V	AT203 0.62 V
AT202	4.5 V	AT204 -0.003

Guard Amplifier (Figures 6-8 and 6-9)

	<i>Emitter</i>	<i>Collector</i>
Q301	8.75 V	12.7 V
Q302	12.7 V	17.8 V
Q303	18.2 V	8.95 V
Positive side of C307	18.2	
AT310	2 V	
AT305	0 V	

Trigger (Figures 6-8 and 6-9)

	<i>Emitter</i>	<i>Collector</i>
Q304	0 V	0.025 V
Q305	0.480 V	0 V
Q306	0.830 V	0 V
AT306	-1.9 V	
AT307	-0.25 V	
AT308	-0.007 V	

Detector (Figures 6-10 and 6-11)

All transistor voltages are to detector low (AT402)

	<i>Emitter</i>	<i>Collector</i>
Q401	0.250 V	3.60 V
Q402	3.00 V	7.80 V
Q403	7.60 V	13.3 V
Q404	5.85 V	13.2 V
Q405	13.3 V	10.0 V
Q406	10.1 V	6.40 V
Q407	5.70 V	12.6 V
Q408	12.7 V	6.10 V
Q409	19.0 V	15.7 V
Q410	9.35 V	18.8 V

AT401 through AT405	1.9 V
AT407	1.9 V
AT408	2 V
AT409	1.9 V
AT410	1.4 V
AT411, 412	-0.28 V
positive side of C407	15.9 V

two-terminal (LOW terminal tied to case). Measure various values between .01 and 1 μ F and all should be within \pm 1% or \pm 1000 pF.

If any measurements are out of tolerance, refer to para 6.5.1 and 6.5.2.

6.8.3 CAPACITANCE-RANGE ACCURACY

To check all ranges of the 1617, capacitance standards from 1000 pF to 100 mF are required. Suggested standards are given in Table 6-7.

A decade box is suggested for values up to 1 μ F. If a GR 1413 is used, the shield of the HIGH terminal should be connected to the 1617 GUARD terminal. A GR 1423 can be used with a two-terminal connection (LOW tied to case). The shielded lead set (P/N 1617-2200) should be used for low values.

To check the lowest range of the 1617, first measure the "zero" capacitance of the bridge, standard, and lead arrangement. For the GR 1413 this can be done by setting the 1413 to zero value and making a measurement obtain-



Table 6-7

Equipment for Minimum Performance Test	
Equipment	Recommended
Decade Capacitor	GR 1423 or GR 1413
Decade Resistor	GR 1433-M (or X, B, F, G or H) GR 1434-M (or B, X or G)
Standard 100 pF to 1 μ F	GR 1423 or GR 1413 Capacitance Decade
Standard 1 μ F to 1 F	GR 1417 or GR 1426

See Appendix for full specifications

ing C_0 . For the GR 1423, disconnect the high lead, support it at least an inch away from the 1423 panel, and make a measurement of C_0 . Then set the decade box to a value of 1000 pF and make a second measurement, C_1 . The value of $C_1 - C_0$ should be within 1000 pF \pm 1%.

The same zero connection should be used if the next range is checked at 1/10 Ω full scale (1000 pF) but has almost negligible effect at full scale (10 μ F).

The higher ranges of the 1617 require high-valued standards such as the GR 1426 or GR 1417. The four-terminal lead set (P/N 1617-2210) should be used (and the shorting links on the 1617 terminals disconnected). For very high values, it is preferable to tightly twist together the two inner leads to reduce mutual inductance (see para 3.1.5).

The connections to the 1426 are between corresponding terminals. The connec-

Table 6-8

Test Connections		
1617 Terminal	1417 Connections	
	"A"	"B"
- UNKNOWN (outside)	+ POTENTIAL	- CURRENT
- UNKNOWN (inside)	+ CURRENT	- POTENTIAL
+ UNKNOWN (inside)	- CURRENT	+ POTENTIAL
+ UNKNOWN (outside)	- POTENTIAL	+ CURRENT

tion to the 1417 depends on the 1617 range as shown in Table 6-9. The two connections, A and B, are given in Table 6-8.

The accuracy of both the 1426 or the 1417 can be checked by determining the value at the 1 μ F setting. This can be done, using the 1617, by first measuring the 1426 or 1417 and then, leaving the 1617 C dial untouched, re-balance the 1617 with a precision decade capacitor connected, using only the decade's adjustment and the 1617 D dial. The indicated value of the decade capacitor should be 1 μ F, within 1/4%.

The accuracy of the 1617 calibration can be improved by using the value of the 1426 or 1417 at 1 μ F, as determined above, as the nominal value at higher settings (when multiplied by the appropriate factor of 10).

6.8.4 DISSIPATION-FACTOR DIAL.

The D dial of the 1617 can be checked by connecting a series combination of a decade resistor and a 1 μ F capacitor to the 1617 and making bridge balances at various

Table 6-9

CALIBRATION WITH 1417							
1417 Setting	1617 Multiplier	Connection	Gen Level(V)	Nom C Read.	C Tol.	D Nominal	D Tol.
1 μ F	100 nF	A or B	2.0	10	\pm 1%	.01	\pm .001
1 μ F	1 μ F	A or B	2.0	1	\pm 1%	.01	\pm .001
10 μ F	1 μ F	A	2.0	10	\pm 1%	.008	\pm .001
10 μ F	10 μ F	A	0.5	1	\pm 1%	.008	\pm .001
100 μ F	10 μ F	A	0.5	10	\pm 1%	.009	\pm .001
100 μ F	100 μ F	A	0.2	1	\pm 1%	.009	\pm .001
1 mF	100 μ F	B	0.2	10	\pm 1%	.01	\pm .001
1 mF	.1 mF	B	0.2	1	\pm 1%	---	
10 mF	1 mF	B	0.2	10	\pm 1%	.01	\pm .0011
10 mF	10 mF	B	0.2	1	\pm 1%	---	
100 mF	10 mF	B	0.2	10	\pm 1%	.01	\pm .002
100 mF	100 mF	B	0.2	1	\pm 2%	---	
1 F	100 mF	B	0.5	10	\pm 2%	.01	\pm .011

- NOTES (1) Use 1417 frequency setting corresponding to test frequency.
 (2) Make two measurements with 1617 input reversed and take average.
 (3) Twist leads at high C values (See para 3.1.5.)

resistance settings. The D dial should read $2 \pi fRC$, to within the D-accuracy specification where R is the resistance of the decade resistor, C is $1 \mu F$, and f is the test frequency in Hz. Suggested resistance settings and the resulting D readings are given in Table 6-5.

6.8.5 DISSIPATION-FACTOR ACCURACY.

The dissipation factor can be checked on various ranges by using series R-C combinations as described above. Only one check for each range is required to ensure that the bridge range resistor (ratio-arm) is not introducing phase shift and hence D error. This check should be made at a low D value for greatest resolution.

Some care must be used when checking the lowest capacitance range, for stray capacitance can cause an appreciable D error. It is preferable to the fixed resistors of known value.

The D accuracy of the higher capacitance ranges can be checked with the GR 1417 four-terminal capacitance standard. The D value that should be read on the 1617 at balance (within the 1617 tolerance) is given in Table 6-9 as the nominal D value. At higher capacitance values, this check should be made only when the capacitance dial is balanced near full scale, because the lead resistance of the 1417 causes excessive D errors at lower settings. Use precautions noted at the bottom of Table 6-9.

6.9 KNOB REMOVAL.

If it should be necessary to remove the knob on a front-panel control, either to replace one that has been damaged or to replace the associated control, proceed as follows:

a. Grasp the knob firmly with the fingers and pull the knob straight away from the panel.

CAUTION

Do not pull on the dial to remove a dial/knob assembly. Always remove the knob first.

b. Observe the position of the set screw in the bushing, with respect to any panel marking (or at the full ccw position of a continuous control).

c. Release the set screw and pull the bushing off the shaft.

d. Remove and retain the black Nylon thrust washer, behind the dial/knob assembly, as appropriate.

NOTE

To separate the bushing from the knob, if for any reason they should be combined off the instrument, drive a machine tap a turn or two into the bushing for a sufficient grip for easy separation.

6.10 KNOB INSTALLATION.

To install a knob assembly on the control shaft:

a. Place the black Nylon thrust washer over the control shaft, if appropriate.

b. Mount the bushing on the shaft, using a small slotted piece of wrapping paper as a shim for adequate panel clearance.

c. Orient the set screw on the bushing with respect to the panel-marking index and lock the set screw.

NOTE

Make sure that the end of the shaft does not protrude through the bushing or the knob won't set properly.

d. Place the knob on the bushing with the retention spring opposite the set screw.

e. Push the knob in until it bottoms and pull it slightly to check that the retention spring is seated in the groove in the bushing.

NOTE

If the retention spring in the knob comes loose, reinstall it in the interior notch with the small slit in the outer wall.

6.11 METER WINDOW CARE

The clear acrylic meter window can become susceptible to electrostatic-charge buildup and can be scratched, if improperly cleaned.

It is treated inside and out in manufacturing with a special non-abrasive anti-static solution, Statnul, which normally should preclude any interference in meter operation caused by electrostatic effects. The problem is evidenced by the inability of the meter movement to return promptly to a zero reading, once it is deenergized. As supplied by General Radio, the meter should return to zero reading within 30 seconds, immediately following the placement of a static charge, as by rubbing the outside surface. This meets the requirements of ANSI standard C39.1-1972.

If static-charge problems occur, possibly as the result of frequent cleaning, the window should be carefully polished with a soft dry cloth, such as cheesecloth or nylon chiffon. Then, a coating of Statnul should be applied with the polishing cloth.

CAUTION

Do not use any kind of solvent. Kleenex or paper towels can scratch the window surface.

If it should be necessary to place limit marks on the meter window, paper-based masking tape is recommended, rather than any kind of marking pen, which could be abrasive or react chemically with the acrylic.

ELECTRICAL PARTS LIST

HIGH VOLTAGE SUPPLY & GENERATOR PRINTED CIRCUIT BOARD (60 HZ) P/N 1617-2720

REFDES	DESCRIPTION	PART NO.	FMC	MFR	PART NUMBER
C 201	CAP ALUM 16 UF 150V	4450-0200	56289	30D166G150DF4	
C 202	CAP CER SQ .10UF 80/20PCT 100V	4403-4100	72982	8131M100651104Z	
C 203	CAP CER DISC 1000PF 80/20PCT 500	4404-2105	72982	0831082Z5U00102Z	
C 204	CAP MYLAR .1UF 2 PCT 100V	4860-8251	56289	410P 0.1 UF 2PCT	
C 205	CAP MYLAR .1UF 2 PCT 100V	4860-8251	56289	410P 0.1 UF 2PCT	
C 206	CAP ALUM 40 UF 6V	4450-3600	56289	30D406G006	
C 207	CAP ALUM 100 UF 25V	4450-2300	56289	30D107G025	
C 208	CAP ALUM 100 UF 25V	4450-2300	56289	30D107G025	
CR 201	DIODE RECTIFIER 1N4003	6081-1001	14433	1N4003	
CR 202	DIODE RECTIFIER 1N645	6082-1016	14433	1N645	
CR 203	ZENER 1N976B 43V 5PCT .4W	6083-1020	07910	1N976B	
CR 204	ZENER 1N967B 18V 5PCT .4W	6083-1016	14433	1N967B	
CR 205	ZENER 1N957B 6.8V 5PCT .4W	6083-1009	07910	1N957B	
CR 206	DIODE RECTIFIER 1N4003	6081-1001	14433	1N4003	
CR 207	DIODE RECTIFIER 1N4003	6081-1001	14433	1N4003	
CR 208	DIODE RECTIFIER 1N4003	6081-1001	14433	1N4003	
CR 209	DIODE RECTIFIER 1N4003	6081-1001	14433	1N4003	
CR 210	DIODE RECTIFIER 1N4003	6081-1001	14433	1N4003	
CR 211	ZENER 1N976B 43V 5PCT .4W	6083-1020	07910	1N976B	
Q 201	TRANSISTOR 2N3414	8210-1290	56289	2N3414	
Q 202	TRANSISTOR 2N3702	8210-1106	01295	2N3702	
Q 203	TRANSISTOR 2N3702	8210-1106	01295	2N3702	
Q 204	TRANSISTOR 2N1304	8210-1304	01295	2N1304	
Q 205	TRANSISTOR 2N1305	8210-1305	01295	2N1305	
Q 212	TRANSISTOR 2N1544	8210-1014	04713	2N1544	
R 201	RES COMP 4.7 K 5PCT 1/2W	6100-2475	81349	RCR20G472J	
R 202	RES COMP 470 K 5PCT 1/2W	6100-4475	81349	RCR20G474J	
R 203	RES COMP 150 OHM 5PCT 1/2W	6100-1155	81349	RCR20G151J	
R 204	RES COMP 1.0 K 5PCT 1/2W	6100-2105	81349	RCR20G102J	
R 205	POT COMP KN0B 5K OHM 10PCT SW U	6045-2510	24655	6045-2510	
R 206	RES COMP 10 K 5PCT 1/2W	6100-3105	81349	RCR20G103J	
R 207	RES COMP 10 K 5PCT 1/2W	6100-3105	81349	RCR20G103J	
R 208	POT WW TRM 5K OHM 10 PCT 20T	6051-2509	80294	3005P-1-502	
R 209	RES COMP 4.7 K 5PCT 1/2W	6100-2475	81349	RCR20G472J	
R 210	RES COMP 10 K 5PCT 1/2W	6100-3105	81349	RCR20G103J	
R 211	RES COMP 120 K 5PCT 1/2W	6100-4125	81349	RCR20G124J	
R 212	RES COMP 20 K OHM 5PCT 1/2W D	6100-3205	81349	RCR20G203J	
R 213	RES COMP 10 K 5PCT 1/2W	6100-3105	81349	RCR20G103J	
R 214	RES FLM 2K 1 PCT 1/8W	6250-1200	81349	RN55D2001F	
R 216	RES FLM 13.0K 1 PCT 1/8W	6250-2130	81349	RN55D1302F	
R 217	RES COMP 100 K 5PCT 1/2W	6100-4105	81349	RCR20G104J	
R 218	RES FLM 15.8K 1 PCT 1/8W	6250-2158	81349	RN55D1582F	
R 219	RES COMP 10 K 5PCT 1/2W	6100-3105	81349	RCR20G103J	
R 220	RES COMP 1.0 K 5PCT 1/2W	6100-2105	81349	RCR20G102J	
R 221	RES COMP 2.0 K OHM 5PCT 1/2W D	6100-2205	81349	RCR20G202J	
R 222	POT WW TRM 1K OHM 10 PCT 20T	6051-2109	80294	3005P-1-102	
R 223	RES COMP 3.0 K OHM 5PCT 1/2W D	6100-2305	81349	RCR20G302J	
R 224	RES COMP 470 OHM 5PCT 1/2W	6100-1475	81349	RCR20G471J	
R 225	RES WW MOLDED .47 OHM 10 PCT 2W	6760-8479	75042	BWH 0.47 OHM 10PCT	
V 201	TUBE VACUUM 7239	8380-7239	02639	7239	

HIGH VOLTAGE SUPPLY & GENERATOR PRINTED CIRCUIT BOARD (50 HZ) P/N 1617-2780

COMPONENTS ARE IDENTICAL TO THE 1617-2720 COMPONENTS
EXCEPT FOR THE FOLLOWING

REFDES	DESCRIPTION	PART NO.	FMC	MFR	PART NUMBER
C 204	CAP MYLAR .121UF 2 PCT 100V	4860-7908	56289	410P 0.121 UF 2PCT	
C 205	CAP MYLAR .121UF 2 PCT 100V	4860-7908	56289	410P 0.121 UF 2PCT	



ELECTRICAL PARTS LIST

GUARD AMPLIFIER & TRIGGER PRINTED CIRCUIT BOARD P/N 1617-2730

REFDES	DESCRIPTION	PART NO.	FMC	MFGR	PART NUMBER
C 301	CAP ALUM 10UF 475V	4450-6175	56289	30D405G475	
C 302	CAP ALUM 10UF 475V	4450-6175	56289	30D405G475	
C 303	CAP MYLAR 0.22UF 10 PCT 400V	4860-9501	24655	4860-9501	
C 304	CAP ALUM 40 UF 6V	4450-3600	56289	30D406G006	
C 305	CAP ALUM 15 UF 15V	4450-3700	56289	30D156G015	
C 306	CAP CER DISC.0047UF80/20PCT500V	4405-2479	72982	0801082Z5U0047ZZ	
C 307	CAP ALUM 40 UF 6V	4450-3600	56289	30D406G006	
C 308	CAP ALUM 60 UF 25V	4450-2900	56289	30D606G025	
C 309	CAP ALUM 60 UF 25V	4450-2900	56289	30D606G025	
C 310	CAP ALUM 10 UF 25V	4450-3800	56289	30D106G025	
C 312	CAP CER DISC.047UF80/20PCT 500V	4409-3479	72982	3851087Z5V0047ZZ	
CR 301	RECT 1N4006 800PIV .5A SI A50A	6081-1004	14433	1N4006	
CR 302	RECT 1N4006 800PIV .5A SI A50A	6081-1004	14433	1N4006	
CR 303	RECT 1N4006 800PIV .5A SI A50A	6081-1004	14433	1N4006	
CR 304	RECT 1N4006 800PIV .5A SI A50A	6081-1004	14433	1N4006	
CR 305	DIODE RECTIFIER 1N4003	6081-1001	14433	1N4003	
CR 306	DIODE RECTIFIER 1N4003	6081-1001	14433	1N4003	
CR 307	DIODE RECTIFIER 1N645	6082-1016	14433	1N645	
CR 308	DIODE RECTIFIER 1N645	6082-1016	14433	1N645	
CR 309	DIODE RECTIFIER 1N645	6082-1016	14433	1N645	
Q 301	TRANSISTOR 2N3414	8210-1290	56289	2N3414	
Q 302	TRANSISTOR 2N3414	8210-1290	56289	2N3414	
Q 303	TRANSISTOR 2N3702	8210-1106	01295	2N3702	
Q 304	TRANSISTOR 2N910	8210-1037	04713	2N910	
Q 305	TRANSISTOR 2N3702	8210-1106	01295	2N3702	
Q 306	TRANSISTOR 2N3702	8210-1106	01295	2N3702	
R 301	RES COMP 220 K 5PCT 1/2W	6100-4225	81349	RCR20G224J	
R 302	RES COMP 150 K 5PCT 1/2W	6100-4155	81349	RCR20G154J	
R 303	RES COMP 47 K 5PCT 1/2W	6100-3475	81349	RCR20G473J	
R 304	RES COMP 100 K 5PCT 1/2W	6100-4105	81349	RCR20G104J	
R 305	RES COMP 10 K 5PCT 1/2W	6100-3105	81349	RCR20G103J	
R 306	RES COMP 4.7 K 5PCT 1/2W	6100-2475	81349	RCR20G472J	
R 307	RES COMP 1.0 K 5PCT 1/2W	6100-2105	81349	RCR20G102J	
R 308	RES COMP 1.0 K 5PCT 1/2W	6100-2105	81349	RCR20G102J	
R 309	RES COMP 1.0 M 5PCT 1/2W	6100-5105	81349	RCR20G105J	
R 310	RES COMP 330 K 5PCT 1/2W	6100-4335	81349	RCR20G334J	
R 311	RES COMP 1.0 K 5PCT 1/2W	6100-2105	81349	RCR20G102J	
R 312	RES WW MOLDED 1 OHM 10 PCT 2W	6760-9109	75042	BWH 1 OHM 10PCT	
R 313	RES WW AX LEAD 100 OHM 5 PCT 5W	6660-1105	75042	AS-5 100 OHM 5PCT	
R 314	RES COMP 100 K 5PCT 1/2W	6100-4105	81349	RCR20G104J	
R 315	RES COMP 1.0 M 10PCT 1W	6110-5109	81349	RCR32G105K	
R 316	RES COMP 1.0 M 10PCT 1W	6110-5109	81349	RCR32G105K	
R 317	RES COMP 100 OHM 5PCT 1/2W	6100-1105	81349	RCR20G101J	
R 318	RES COMP 2.0 K OHM 5PCT 1/2W	6100-2205	81349	RCR20G202J	

REFERENCE DESIGNATOR ABBREVIATIONS

B = Motor	P = Plug
BT = Battery	Q = Transistor
C = Capacitor	R = Resistor
CR = Diode	S = Switch
DS = Lamp	T = Transformer
F = Fuse	U = Integrated Circuit
J = Jack	VR = Diode, Zener
K = Relay	X = Socket for Plug-In
KL = Relay Coil	Y = Crystal
KS = Relay Switch	Z = Network
L = Inductor	
M = Meter	References
MK = Microphone	ASA Y32.16 and MIL-STD-16C



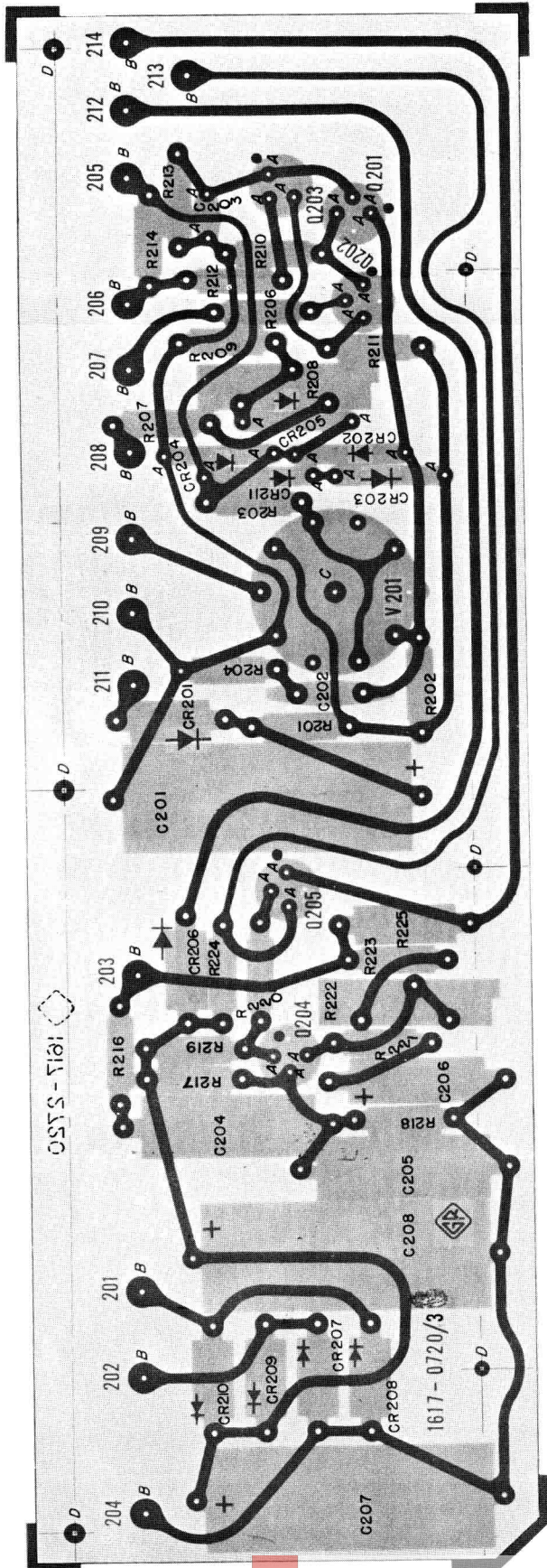

Figure 6-7. The high-voltage supply and the generator etched board (P/N 1617-2780) for 50-Hz units, or (P/N 1617-2720) for 60-Hz units.

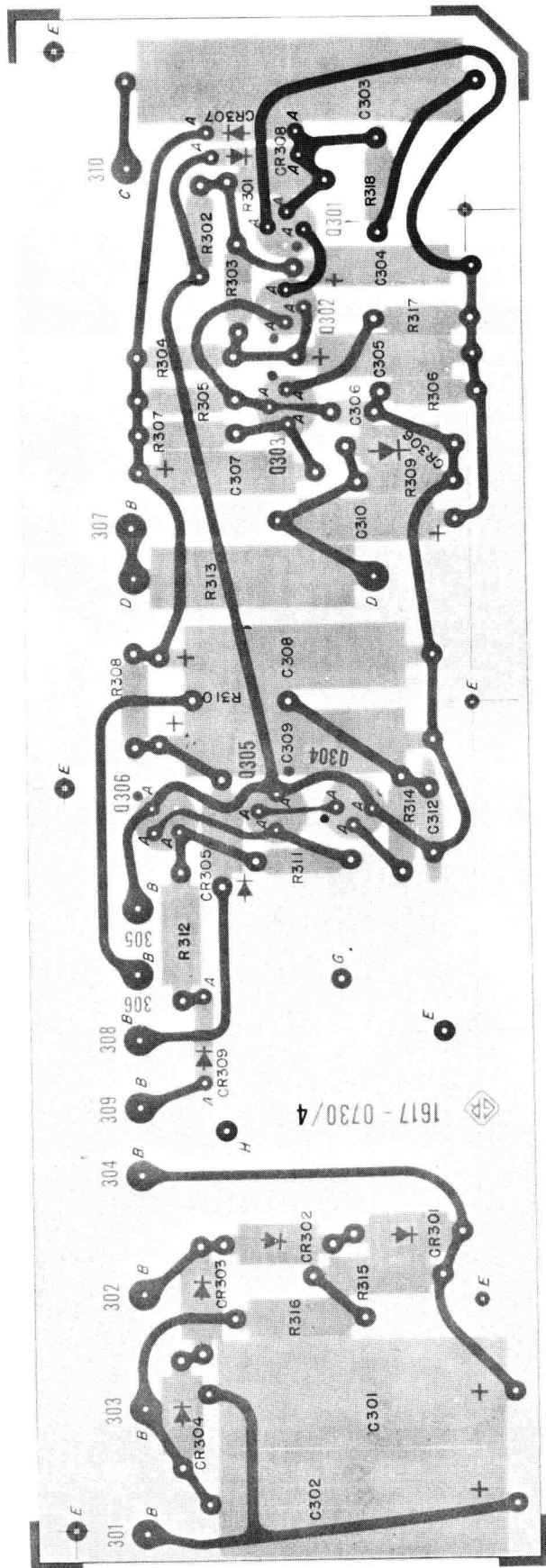

Figure 6-8. The guard amplifier and trigger etched board (P/N 1617-2730).

NOTE: The number on the foil side is not the part number for the complete assembly. The dot on the foil at the transistor socket indicates the collector lead.

ELECTRICAL PARTS LIST

DETECTOR PRINTED CIRCUIT BOARD (60 HZ) P/N 1617-2700

REFDES	DESCRIPTION	PART NO.	FMC	MFGR	PART NUMBER
C 401	CAP CER DISC .01UF 80/20PCT 500V	4406-3109	72982	0811082Z5U00103Z	
C 402	CAP CER SQ .10UF 80/20PCT 100V	4403-4100	72982	8131M100651104Z	
C 403	CAP CER DISC 470PF 10PCT 500V	4404-1475	72982	0831082Z5D00471K	
C 404	CAP ALUM 5 UF 50V	4450-3900	56289	30D505G050	
C 405	CAP ALUM 5 UF 50V	4450-3900	56289	30D505G050	
C 406	CAP ALUM 5 UF 50V	4450-3900	56289	30D505G050	
C 407	CAP ALUM 10 UF 25V	4450-3800	56289	30D106G025	
C 408	CAP ALUM 10 UF 25V	4450-3800	56289	30D106G025	
C 409	CAP CER DISC 0.22UF 80/20PCT 12V	4432-4229	72982	5615-000-Y5F-224Z	
C 410	CAP ALUM 10 UF 25V	4450-3800	56289	30D106G025	
C 411	CAP MYLAR .02UF 1 PCT 100V	4860-7853	56289	410P .02 UF 1PCT	
C 412	CAP MYLAR .02UF 1 PCT 100V	4860-7853	56289	410P .02 UF 1PCT	
C 413	CAP MYLAR .04UF 1 PCT 100V	4860-7836	56289	410P .04 UF 1PCT	
C 414	CAP CER DISC .01UF 80/20PCT 100V	4401-3100	72982	0805540Z5U00103Z	
C 415	CAP CER DISC 470PF 10PCT 500V	4404-1475	72982	0831082Z5D00471K	
C 416	CAP ALUM 10 UF 25V	4450-3800	56289	30D106G025	
C 417	CAP CER SQ .10UF 80/20PCT 100V	4403-4100	72982	8131M100651104Z	
C 418	CAP ALUM 10 UF 25V	4450-3800	56289	30D106G025	
C 419	CAP ALUM 5 UF 50V	4450-3900	56289	30D505G050	
C 420	CAP ALUM 10 UF 25V	4450-3800	56289	30D106G025	
C 421	CAP ALUM 5 UF 50V	4450-3900	56289	30D505G050	
C 422	CAP CER SQ .10UF 80/20PCT 100V	4403-4100	72982	8131M100651104Z	
C 423	CAP ALUM 60 UF 25V	4450-2900	56289	30D606G025	
CR 401	DIODE RECTIFIER 1N4003	6081-1001	14433	1N4003	
CR 402	DIODE RECTIFIER 1N645	6082-1016	14433	1N645	
CR 403	DIODE RECTIFIER 1N645	6082-1016	14433	1N645	
CR 404	DIODE RECTIFIER 1N645	6082-1016	14433	1N645	
CR 405	DIODE RECTIFIER 1N645	6082-1016	14433	1N645	
CR 406	DIODE RECTIFIER 1N645	6082-1016	14433	1N645	
CR 407	DIODE RECTIFIER 1N645	6082-1016	14433	1N645	
CR 408	DIODE RECTIFIER 1N645	6082-1016	14433	1N645	
CR 409	DIODE 1N191 90PIV IR 125UA GE	6082-1008	14433	1N191	
CR 410	DIODE RECTIFIER 1N4003	6081-1001	14433	1N4003	
CR 411	ZENER 1N957B 6.8V 5PCT .4W	6083-1009	07910	1N957B	
Q 401	TRANSISTOR 2N930	8210-1002	01295	2N930	
Q 402	TRANSISTOR 2N3414	8210-1290	56289	2N3414	
Q 403	TRANSISTOR 2N1304	8210-1304	01295	2N1304	
Q 404	TRANSISTOR 2N1304	8210-1304	01295	2N1304	
Q 405	TRANSISTOR 2N1305	8210-1305	01295	2N1305	
Q 406	TRANSISTOR 2N1305	8210-1305	01295	2N1305	
Q 407	TRANSISTOR 2N1304	8210-1304	01295	2N1304	
Q 408	TRANSISTOR 2N1305	8210-1305	01295	2N1305	
Q 409	TRANSISTOR 2N1305	8210-1305	01295	2N1305	
Q 410	TRANSISTOR 2N1304	8210-1304	01295	2N1304	
R 403	RES COMP 1.0 K 5PCT 1/2W	6100-2105	81349	RCR20G102J	
R 404	RES COMP 1.0 M 5PCT 1/2W	6100-5105	81349	RCR20G105J	
R 405	RES COMP 22 M 5PCT 1/2W	6100-6225	81349	RCR20G226J	
R 406	RES COMP 100 K 5PCT 1/2W	6100-4105	81349	RCR20G104J	
R 407	RES COMP 62 K OHM 5PCT 1/2W	6100-3625	81349	RCR20G623J	

ELECTRICAL PARTS LIST

DETECTOR PRINTED CIRCUIT BOARD (60 HZ) P/N 1617-2700

REFDES	DESCRIPTION	PART NO.	FMC	MFR	PART	NUMBER
R 408	RES COMP 30 K OHM 5PCT 1/2W	6100-3305	81349		RCR20G303J	
R 409	RES COMP 3.0 K OHM 5PCT 1/2W	6100-2305	81349		RCR20G302J	
R 410	RES COMP 470 OHM 5PCT 1/2W	6100-1475	81349		RCR20G471J	
R 411	RES COMP 10 K 5PCT 1/2W	6100-3105	81349		RCR20G103J	
R 412	RES COMP 470 OHM 5PCT 1/2W	6100-1475	81349		RCR20G471J	
R 413	RES COMP 2.0 K OHM 5PCT 1/2W	6100-2205	81349		RCR20G202J	
R 414	RES COMP 4.7 K 5PCT 1/2W	6100-2475	81349		RCR20G472J	
R 415	RES COMP 10 K 5PCT 1/2W	6100-3105	81349		RCR20G103J	
R 416	RES COMP 4.3 K OHM 5PCT 1/2W	6100-2435	81349		RCR20G432J	
R 417	RES COMP 16 K OHM 5PCT 1/2W	6100-3165	81349		RCR20G163J	
R 418	RES COMP 10 K 5PCT 1/2W	6100-3105	81349		RCR20G103J	
R 419	RES COMP 22 K 5PCT 1/2W	6100-3225	81349		RCR20G223J	
R 420	RES COMP 5.1 K OHM 5PCT 1/2W	6100-2515	81349		RCR20G512J	
R 421	RES COMP 100 K 5PCT 1/2W	6100-4105	81349		RCR20G104J	
R 422	RES FLM 66.5K 1 PCT 1/8W	6250-2665	81349		RN55D6652F	
R 423	RES FLM 66.5K 1 PCT 1/8W	6250-2665	81349		RN55D6652F	
R 424	RES FLM 33.2K 1 PCT 1/8W	6250-2332	81349		RN55D3322F	
R 425	RES COMP 10 K 5PCT 1/2W	6100-3105	81349		RCR20G103J	
R 426	RES COMP 10 K 5PCT 1/2W	6100-3105	81349		RCR20G103J	
R 427	RES COMP 160 K OHM 5PCT 1/2W	6100-4165	81349		RCR20G164J	
R 428	RES COMP 100 K 5PCT 1/2W	6100-4105	81349		RCR20G104J	
R 429	RES COMP 15 K 5PCT 1/2W	6100-3155	81349		RCR20G153J	
R 430	RES COMP 1.0 K 5PCT 1/2W	6100-2105	81349		RCR20G102J	
R 431	RES COMP 10 K 5PCT 1/2W	6100-3105	81349		RCR20G103J	
R 432	RES COMP 4.7 K 5PCT 1/2W	6100-2475	81349		RCR20G472J	
R 433	RES COMP 100 K 5PCT 1/2W	6100-4105	81349		RCR20G104J	
R 434	RES COMP 3.9 K 5PCT 1/2W	6100-2395	81349		RCR20G392J	
R 435	RES COMP 1.0 K 5PCT 1/2W	6100-2105	81349		RCR20G102J	
R 436	RES COMP 6.8 K 5PCT 1/2W	6100-2685	81349		RCR20G682J	
R 437	RES COMP 10 K 5PCT 1/2W	6100-3105	81349		RCR20G103J	
R 438	RES COMP 10 K 5PCT 1/2W	6100-3105	81349		RCR20G103J	
R 439	RES COMP 4.7 K 5PCT 1/2W	6100-2475	81349		RCR20G472J	
R 440	RES COMP 1.0 K 5PCT 1/2W	6100-2105	81349		RCR20G102J	
R 441	RES COMP 47 K 5PCT 1/2W	6100-3475	81349		RCR20G473J	
R 442	RES COMP 10 K 5PCT 1/2W	6100-3105	81349		RCR20G103J	
R 443	POT COMP KNOB 50K OHM 10PCT LOG	6020-0600	01121		JAIN056S503AZ	

DETECTOR PRINTED CIRCUIT BOARD (50 HZ) P/N 1617-2770
 COMPONENTS ARE IDENTICAL TO THE 1617-2700 COMPONENTS
 EXCEPT FOR THE FOLLOWING

REFDES	DESCRIPTION	PART NO.	FMC	MFR	PART	NUMBER
C 411	CAP MYLAR .0243UF 1 PCT 100V	4860-7833	56289	410P	.0243 UF 1PCT	
C 412	CAP MYLAR .0243UF 1 PCT 100V	4860-7833	56289	410P	.0243 UF 1PCT	
C 413	CAP MYLAR .0475UF 1 PCT 100V	4860-8204	56289	410P	.0475 UF 1PCT	



- NOTE UNLESS SPECIFIED
- | | |
|---|---|
| 1. POSITION OF ROTARY SWITCHES SHOWN COUNTERCLOCKWISE | 5. RESISTANCE IN OHMS
K 1000 OHMS M 1 MEGOHM |
| 2. CONTACT NUMBERING OF SWITCHES EXPLAINED ON SEPARATE SHEET SUPPLIED IN INSTRUCTION BOOK | 6. CAPACITANCE VALUES ONE AND OVER IN PICOFARADS. LESS THAN ONE IN MICROFARADS. |
| 3. REFER TO SERVICE NOTES IN INSTRUCTION BOOK FOR VOLTAGES APPEARING ON DIAGRAM | 7. ○ KNOB CONTROL |
| 4. RESISTORS 1/2 WATT | 8. ○ SCREWDRIVER CONTROL |
| | 9. AT ANCHOR TERMINAL |
| | 10. TP TEST POINT |

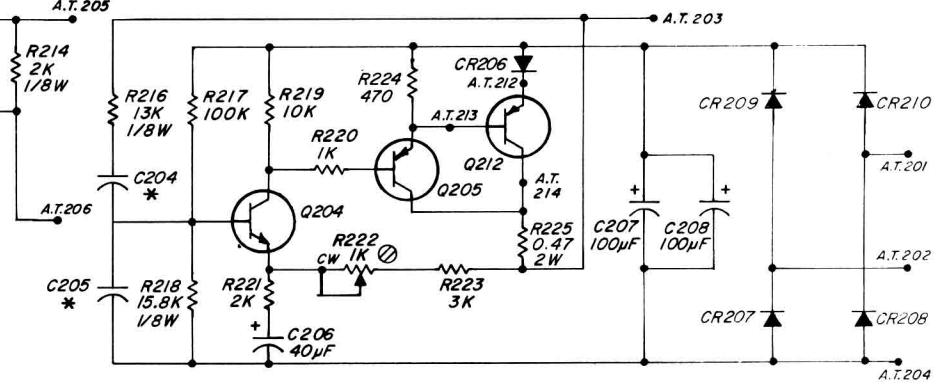
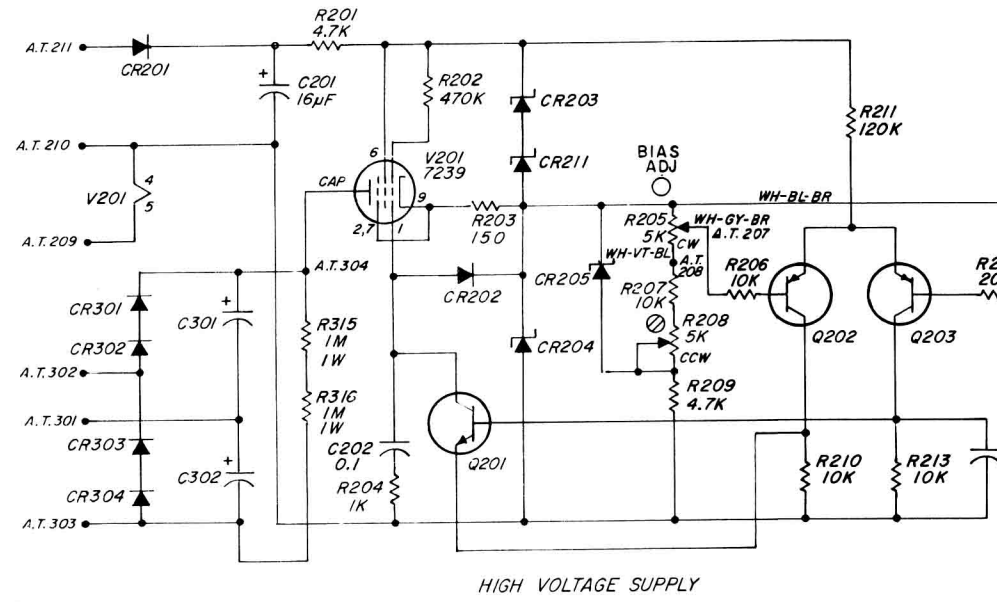

INSTRUMENT	* C204	* C205
1617 50c LINE	0.121	0.121
1617 60c LINE	0.1	0.1

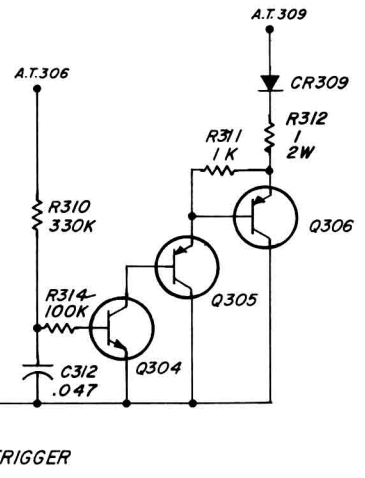
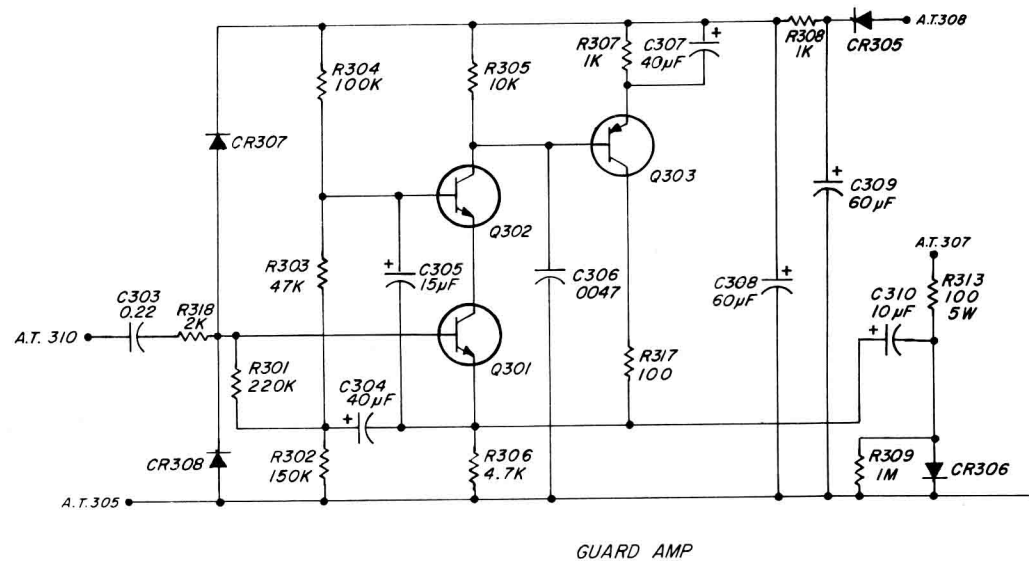

Figure 6-9. Schematic diagram of the high-voltage supply, guard, trigger and generator circuits.



FEDERAL SUPPLY CODE

FOR MANUFACTURERS

Ref FMC Column

From Defense Logistics Agency Microfiche

in Parts Lists

H4-2 SB 708-42 GSA-FSS H4-2

Code	Manufacturer	Code	Manufacturer	Code	Manufacturer	Code	Manufacturer
00136	McCoy Elctns.,Mt.Holly Sprinas,PA 17065	15605	Cutler Hammer, Milwaukee,WI 53202	56289	Sprague,North Adams,MA 01247	80894	Pure Carbon,St Marys,PA 15857
00192	Jones Mfg.,Chicago,IL 60181	15782	Houston Inst.,Bellaire,TX 77401	57771	Stimpson,Bayport,NY 11705	81030	Int'l Inst.,Orange,CT 06477
00194	Waisco Elctns.,Los Angeles,CA 90018	15801	Fenwal Elctns.,Framingham,MA 01701	58563	Superior Valve,Washington,PA 15301	81073	Grayhill,LaGrange,IL 60525
00327	Welwyn Intntl.,Westlake,OH 44145	15819	Sinclair & Rush,St.Louis,MO 63111	59730	Thomas & Betts,Elizabeth,NJ 07207	81143	Isolantite,Strirling,NJ 07980
00434	Schwaber Elctns.,Westburg,NY 11590	16037	Spruce Pine Mica,Spruce Pine,NC 28777	59775	TRW,Cleveland,OH 44117	81172	Winchester,Oakville,CT 06779
00656	Aerovox,New Bedford,MA 02745	16068	Intnst Diode,Jersey City,NJ 07304	60399	Torrington,Torrington,CT 06790	81349	Military Specifications
00779	AMP Inc.,Harrisburg,PA 17105	16179	Ommi Spectra,Farmington,MI 48024	61007	Townsend,Braintree,MA 02184	81350	Joint Army-Navy Specifications
01009	ALDEN Products,Brockton,MA 02413	16301	Astrolab,Linden,NJ 07036	61637	Union Carbide,New York,NY 10017	81483	Int'l Rectifier,El Segundo,CA 90245
01121	Allan Bradley,Milwaukee,WI 53204	16352	Codi,Fairlawn,NJ 07410	61864	United Carr Fast,Boston,MA	81741	Chicago Lock,Chicago,IL 60641
01255	Litton Inds.,Beverly Hills,CA 90213	16485	Sterling Inst.,New Hyde Park,NY 11040	63060	Victoreen,Cleveland,OH 44104	81831	Filtron,Flushing,NY 11354
01281	TRW,Lawndale,CA 90260	16636	Indiana General,Oglesby,IL 61348	63743	Ward Leonard,Mt.Vernon,NY 10550	81840	Ledex,Dayton,OH 45402
01295	TI,Dallas,TX 75222	16758	Delco,Kokomo,IN 46901	65083	Westinghouse,Bloomfield,NJ 07003	81860	Barry Wright,Watertown,MA 02172
01526	GE,Waynesboro,VA 22980	16952	Precision Dynamics,Burbank,CA 91504	65092	Weston,Newark,NJ 07114	82219	Sylvania,Emporium,PA 15834
01930	Amerock,Rockford,IL 61101	16952	Amer Micro Devices,Summerville,SC 29483	70106	Acushnet Cap.,New Bedford,MA 02742	82227	No.Amer.Philips,Cheshire,CT 06410
01963	Cherry Elctrs.,Waukegan,IL 60085	17117	Elctrc Molding,Woonsocket,RI 02895	70139	Edco & Westlake,Elkhart,IN 46514	82273	Int'l Pattern & Model,LaPorte,IN 46350
02111	Spectrol Elctns.,City of Industry,CA 91745	17540	Mohawk Springwood,Par,IL 60176	70417	Chrysler,Detroit,MI 48231	82389	Switchcraft,Chicago,IL 60630
02112	Ferrox Elctrs.,Saugerties,NY 12477	17745	Angstrohm Prestr.,Hagerstown,MD 21740	70485	Atlantic India Rubber,Chicago,IL 60607	82567	Reeves Hoffman,Carleisle,PA 17013
02606	Fenwall Lab.,Morton Grove,IL 60053	17771	Singer,Somerville,NJ 08876	70563	Amperite,Union City,NJ 07087	82647	Metals & Controls,Attleboro,MA 02703
02639	GE,Schenectady,NY 12307	17850	Zeltex,Concord,CA 94520	70611	Ark-Les Switch,Waterbury,CT 06726	82807	Milwaukee Resistor,Milwaukee,WI 53204
02660	Amphenol,Broadview,IL 60153	17856	Siliconix,Santa Clara,CA 95054	70892	Bead Chain,Bridgeport,CT 06605	82877	Rotron,Woodstock,NY 12498
02735	RCA,Somerville,NJ 08876	18324	Signetics,Sunnyvale,CA 94086	70903	Belden,Chicago,IL 60644	82901	IN General Magnet,Valparaiso,IN 46383
02768	Fastex,Desplains,IL 60016	18542	New Prod Eng,Wabash,IN 46992	71126	Bronson,Beacon Falls,CT 06403	83003	Varo,Garland,TX 75040
03042	Carter Ink.,Cambridge,MA 02142	18677	Scanbee,El Monte,CA 91731	71279	Cambridge Thermionic,Cambridge,MA 02138	83014	Hartwell,Placentia,CA 92670
03508	GE,Syracuse,NY 13201	18736	Computer Diode,S.Fairlawn,NJ 07936	71294	Canfield,Clifton Forge,VA 24422	83033	Meissner,Mt Carmel,IL 62863
03550	Vanguard Elctns.,Inglewood,CA 90302	18795	Cyccon,Sunnyvale,CA 94086	71400	Busmann,St.Louis,MO 63107	83058	Carr Fastener,Cambridge,MA 02142
03636	Graybar,New York,NY 10701	18911	Durant,Waterbury,CT 06726	71450	CTS,Elkhart,IN 46514	83186	Victory Eng.,Springfield,IL 62701
03877	Transiron Elctns.,Wakefield,MA 01880	19178	Zero,Monson,MA 01057	71468	Cannon,Los Angeles,CA 90031	83259	Parker Seal,Culver City,CA 90231
03888	KDI Pyrofilm,Whippany,NJ 07981	19209	GE,Gainesville,FL 32601	71482	Clare,Chicago,IL 60645	83330	H.K.Smith,Brooklyn,NY 11207
03911	Claires,New York,NY 10001	19373	Eastron,Haverhill,MA 01830	71590	Centralab,Milwaukee,WI 53212	83361	Bearing Spclty.,San Francisco,CA
04009	Arrow Hart,Hartford,CT 06106	19396	Paktron,Vienna,VA 22180	71666	Continental Carbon,New York,NY	83587	Solar Elctc.,Warren,PA 16365
04643	Digitronics,Albertson,NY 11507	19617	Labtron,Chicago,IL 60622	71707	Coto Coil,Providence,RI 02905	83594	Burroughs,Plainfield,IL 07061
04713	Motorola,Phoenix,AZ 85008	19644	LCR Elctns.,Horseheads,NY 14845	71729	Crescent Box,Philadelphia,PA 19134	83740	Union Carbide,New York,NY 10017
04919	Component Mfg.,W.Bridgewater,MA 02379	19701	Electa,Independence,KS 67301	71744	Chicago Min Lamp,Chicago,IL 60640	83766	Mass Engrg.,Quincy,MA 02171
05079	Transistor Elctns.,Bennington,VT 05201	20093	Elctc Incls.,Murray Hill,NJ 07974	71785	Cinch,Chicago,IL 60624	83781	National Electronics,Genewa,IL 60134
05245	Corcom,Chicago,IL 60638	20754	KMC,Long Valley,NJ 07853	71823	Darnell,Downey,CA 90241	84411	TRW,Opalala,NB 69153
05276	ITT Elctc.,Pomona,CA 91766	21335	Fatirn Bearing,New Britain,CT 06050	72136	Continental Screw,New Bedford,MA 02742	84835	Lark Metals,Cambridge,MA 02140
05402	Controls Co. of Amer.,Melrose Pk,IL 60160	21688	Ruythoen,New York,NY 10022	72222	Continental Screw,New Bedford,MA 02742	84970	Sehjes Tarzian,Bloomington,IN 47401
05574	Viking Inds.,Chatsworth,CA 91311	21759	Lenox Fugle,Watchung,NJ 07060	72259	Nytronics,Berkeley,Hts,NJ 07922	84971	Ta Mfg.,Los Angeles,CA 90039
05624	Barber Colman,Rockford,IL 61101	22526	Berg Elctrs.,New Cumberland,PA 17070	72619	Dialight,Brooklyn,NY 11237	85604	Kepco,Flushing,NY 11352
05748	Barnes Mfg.,Mansfield,OH 44901	22589	Electro Space Fabrctrs.,Topton,PA 19562	72659	General Inst.,Newark,NJ 07104	85420	Payson Casters,Gurnee,IL 60031
05820	Wakefield Eng.,Wakefield,MA 01880	22753	UID Elctrcs.,Hollywood,FL 33022	72765	Drake,Chicago,IL 60631	86577	Pre Metal Prod.,Stoneham,MA 02180
06383	Panduit,Tinley Pk,IL 60477	23338	Wavetek,San Diego,CA 92112	72794	Dzus Fastener,W.Islip,NY 11795	86684	RCA,Harrison,NJ 07029
06406	Truelove & Maclean,Waterbury,CT 06708	23342	Avnet Elctcs.,Franklin Park,IL 60131	72825	Eby,Philadelphia,PA 19144	86687	REC,New Rochelle,NY 10801
06665	Precision Monolith,Santa Clara,CA 95050	23936	Pamator,Bulingham,CA 94010	72962	Elastic Stop Nut,Union,NJ 07083	86800	Cont Elctcs.,Brooklyn,NY 11222
06743	Clevite,Cleveland,OH 44110	24351	Indiana Gnr Elctc.,Keasby,NJ 08832	72992	Elrie,Erie,PA 16512	88140	Cutter Hammer,Lincoln,IL 62856
06795	WLS Stamp,Cleveland,OH 44104	24355	Analog Devices,Cambridge,MA 02142	73445	Amperite,Union City,NJ 07087	88204	GTE Sylvania,Isipwisch,MA 01938
06915	Richco Plstc.,Chicago,IL 60646	24444	General Semcond.,Trenton,NJ 08621	73559	Sarling Elctc.,Hartford,CT 06110	88219	Gould Nat Battery,Trenton,NJ 08607
06928	Telchco Kncts.,Soland Bch,CA 92075	24446	GE,Schenectady,NY 12305	73690	Elco Resistor,New York,NY	88419	Corneil Dubilier,Fuquay Varina,NC 27526
06978	Aladdin Elctns.,Nashville,TN 37210	24454	GE,Syracuse,NY 13201	73803	TI,Attleboro,MA 02703	88627	K&G Mfr.,New York,NY
07047	Ros Milton,Southington,PA 18966	24565	EMC Technlgy,Cherry Hill,NJ 08034	73899	JFD Elctcs.,Brooklyn,NY 11219	89265	Potter & Brumfield,Princeton,IN 47671
07126	Digitran,Pasadena,CA 91105	24602	Gen Rad.,Concord,MA 01742	73957	Groov-Pin,Ridgefield,NJ 07657	89482	Holtzer Cabot,Boston,MA 02119
07127	Eagle Signal,Baraboo,WI 53913	24655	Lenox Fugle,S.Plainfield,NJ 07080	74193	Heinemann,Trenton,NJ 08602	89665	United Transformer,Chicago,IL
07233	Cinch Graphik,City of Industry,CA 91744	24759	Vacite,Berkeley,CA 94710	74199	Quam Nichols,Chicago,IL 60637	89870	Berkshire Transformer,Kent,CT 06757
07261	Avnet,Culver City,CA 90230	25008	EG&G,Bedford,MA 01730	74445	Holo-Krome,Hartford,CT 06110	90201	Mallory Cap.,Indianapolis,IN 46206
07263	Fairchild,Mountain View,CA 94040	25289	Tri-County Tube,Nunda,NY 14517	74545	Hubbell,Stratford,CT 06497	90303	Mallory Bat.,Tarrytown,NY 10591
07387	Birtcher,N.Los Angeles,CA 90032	26801	Omni Spectra,Waltham,MA 02154	74861	Industrial Cndrs.,Chicago,IL 60618	90334	Gulton Inds.,Metuchen,NJ 08840
07595	Amer.Semicond.,Arlington Hts,IL 60004	26805	American Zettler,Costa Mesa,CA 92626	74868	Amphenol,Danbury,CT 06810	90750	Westinghouse,Boston,MA 02118
07699	Magnetic Core,Newburgh,NY 12550	27014	National,Santa Clara,CA 95051	74970	Johnson,Waseca,MN 56093	90952	Hardware Prod.,Reading,PA 19602
07707	USM Fastener,Shelton,CT 06484	27545	Hartford Universal Ball,Rocky Hill,CT 06067	75042	IRCTR(W),Burlington,IA 52601	91032	Continental Wire,York,PA 17405
07828	Bodine,Bridgeport,CT 06605	28480	HP,Palo Alto,CA 94304	75376	Kurz-Kasch,Dayton,OH 45401	91146	Canon,Salem,MA 01970
07829	Bodine Elctc.,Chicago,IL 60618	28520	Heyman Mfg.,Kenilworth,NJ 07033	75382	Kuka,Mt Vernon,NY 10551	91210	Gerber,Mishawaka,IN 46544
07910	Cont Devis.,Hawthorne,CA 90250	28875	IMC Magnetics,Rochester,NJ 03867	75491	Lafayette,Syosset,NY 11791	91293	Johnson,Boonton,NJ 07005
07983	State Labs.,New York,NY 10003	28959	Hoffman Elctcs.,El Monte,CA 91734	75608	Linden,Providence,RI 02905	91417	Harris,Melbourne,FL 32901
07999	Borg Inst.,Delavan,WI 53115	30043	Solid State Devices,LaMirada,CA 90638	75915	Littelfuse,Des Plaines,IL 60016	91506	Dual Bros.,Attleboro,MA 02703
08524	Deutsch Fastener,Los Angeles,CA 90045	30646	Beckman Inst.,Cedar Grove,NJ 07009	76005	Lord Mfg.,Erie,PA 16512	91598	Amperite,Westfield,CT 06109
08556	Bell Elctc.,Chicago,IL 60632	30874	GM,Ammon,NY 10604	76241	Mallory Elctc.,New York,PA 48204	91637	Alle Electronics,Columbus,NE 68601
09213	GE,Buffalo,NY 14220	30985	Permag Magnetics,Toledo,OH 43609	76281	3 M Co.,St.Paul,MN 55116	91662	Elco,Willow Grove,PA 19090
09353	C&K Components,Watertown,MA 02172	31019	Solid State Scntfc.,Montgomeryville,PA 18936	76385	Minor Rubber,Bloomfield,NJ 07003	91769	General Inst.,Dallas,TX 75220
09408	Star-Tronics,Georgetown,MA 01830	31514	Standford Appld Engs.,Costa Mesa,CA 92626	76387	Millen,Malden,MA 02148	91836	Kings Elctcs.,Tuckaohoe,NY 12233
09623	Burgess Battery,Freeport,IL 61032	31814	Analogic,Wakefield,MA 01880	76487	Mueller Elctc.,Cleveland,OH 44114	91916	Mephisto Tool,Hudson,NY 11524
09856	Fenwal Elctcs.,Framingham,MA 01701	31951	Triridge,Pittsburgh,PA 15231	76545	National Tube,Pittsburgh,PA 15219	91929	Innoswell,Freeport,IL 61032
09922	Burndy,Norwalk,CT 06852	32001	Jensen,Chicago,IL 60638	76684	Oak Inds.,Crystal Lake,IL 60014	92519	Electra Inyl.,Woodside,NY 11377
10025	Glasseal Prod.,Linden,NJ 07036	33095	Spectrum Control,Fairview,PA 16415	76854	Tod Fastener,Waterbury,CT 06720	92678	Edgerton Gernshausen,Boston,MA 02115
10389	Chicago Switch,Chicago,IL 60647	33173	GE,Owensboro,KY 42301	77132	Patton MacGuer,Providence,RI 02905	92702	IMC Magnetics,Westbury,NY 11591
11236	CTS of Berne,Berne,IN 46711	34141	Koehler,Marlboro,MA 01752	77147	Patterson,Providence,RI 02905	92739	Amperite,Westfield,CT 06109
11599	Chandler,Evans,W.Hartford,CT 06101	34156	Semicon,Costa Mesa,CA 92626	77263	Pierce Roberts Rubber,Trenton,NJ 08638	92966	Hudson Lamp,Kearny,NJ 07032
11983	Nortronics,Mineapolis,MN 55427	34333	Advanced Micro Devices,Sunnyvale,CA 94086	77315	Platt Bros.,Waterbury,CT 06720	93332	Sylvania,Woburn,MA 01801
12040	National,Santa Clara,CA 95051	34649	Intel,Santa Clara,CA 95051	77339	Positive Lockwasher,Newark,NJ	93346	Amer Elctcs,Lansdale,PA 19446
12045	Elctrc Transistors,Flushing,NY 11354	34677	Soliton Devices,Jupiter,FL 33458	77342	RAF,Princeton,IN 47570	93618	R&C Mfg.,Ramsey,PA 16671
12498	Telcayne,Mountain View,CA 94043	35629	Constanta,Montreal,QUE,CAN	77542	Ray-o-Vac,Madison,WI 53703	93916	Cramer,New York,NY 10013
12617	Hamlin,Lake Mills,WI 53551	35929	National Ltd.,Montreal,QUE,CAN	77630	TRW,Camden,NJ 08103	94144	Wagner,Quincy,MA 02169
12672	RCA,Woodbridge,NJ 07095	37942	Mallory,Indianapolis,IN 46206	77638	General Inst.,Brooklyn,NY 11211	94154	Weston,Livingston,NJ 07039
12697	Clarostrat,Dover,NH 03820	38443	Marlin Rockwell,Jamestown,NY 14701	78189	Shakeproof,Elgin,IL 60120	94271	Wagner,Archbold,PA 18403
12856	Micrometals,City of Industry,CA 91744	39317	McGill Mfg.,Valparaiso,IN 46383	78277	Sigma Inst.,Baintree,MA 02184	94322	Tel Labs,Manchester,NH 03102
12954	Dickson Elctns.,Scottsdale,AZ 85252	40391	Howenell,Mineapolis,MN 55408	78429	Airco Super,St Marys,PA 15867	94589	Chickson,Chicago,IL 60619
12969	Unirode,Watertown,MA 02172	42190	Muter,Chicago,IL 60638	78488	Stackpole,St Marys,PA 15867	94696	Magnecraft,Chicago,IL 60630
13094	Electrocraft,Hopkins,MN 55343	42498	National,Melrose,MA 02176	78553	Tinnerman,Cleveland,OH	94800	Atlas Ind.,Brookline,NH 03033
13103	Thermalloy,Dallas,TX 75234	43334	New Departure-Hyatt,Sandusky,OH 44870	78711	Telephonics,Huntington,NY 11743	95076	Garde,Cumberland,RI 02864
13148	Vogue Inst.,Richmond Hill,NY 11418	43991	Norma Hoffman,Stanford,CT 06904	79089	RCA,Harrison,NJ 07029	95121	Quality Comp.,St Marys,PA 15857
13150	Vernitron,Laconia,NH 03246	49671	RCA,New York,NY 10020	79136	Walde Kohinoor,New York,NY 11101	95146	Alco Elctcs.,Lawrence,MA 01843
13327	Soliton Devices,Tappan,NY 10983	49956	Raytheon,Waltham,MA 02154	79497	Western Rubber,Goshen,IN 46526	95238	Continental Con.,Woodside,NY 11377
13715	Fairchild,San Rafael,CA 94903	50088	Mostek,Carrollton,TX 75060	79725	Wiremold,Hartford,CT 06110	95275	Vitramon,Bridgeport,CT 0

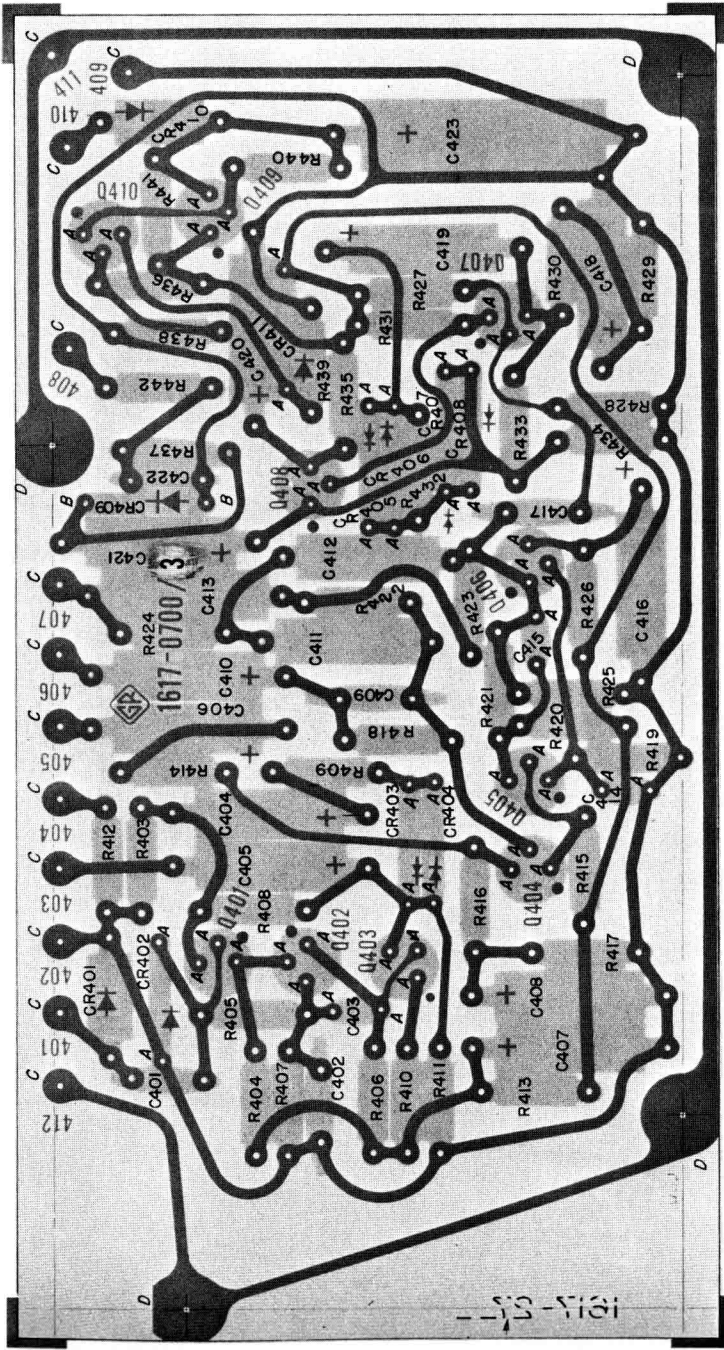
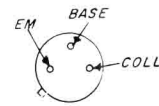
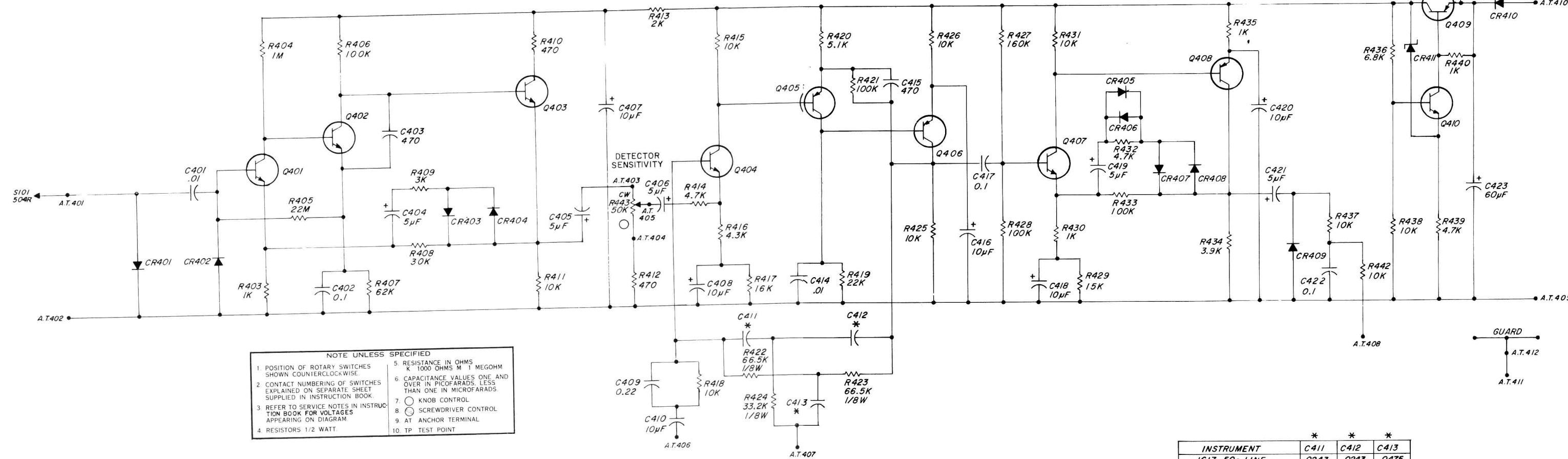

Figure 6-10. The detector etched board, (P/N 1617-2770) for 50-Hz units or P/N 1617-2700 (for 60 Hz units).

NOTE: The number on the foil side is not the part number for the complete assembly. The dot on the foil at the transistor socket indicates the collector lead.



TRANSISTOR OUTLINE
BOTTOM VIEW
Q401, Q403 THRU Q410



- NOTE UNLESS SPECIFIED
1. POSITION OF ROTARY SWITCHES SHOWN COUNTERCLOCKWISE.
 2. CONTACT NUMBERING OF SWITCHES EXPLAINED ON SEPARATE SHEET SUPPLIED IN INSTRUCTION BOOK.
 3. REFER TO SERVICE NOTES IN INSTRUCTION BOOK FOR VOLTAGES APPEARING ON DIAGRAM.
 4. RESISTORS 1/2 WATT.
 5. RESISTANCE IN OHMS K 1000 OHMS M 1 MEGOHM
 6. CAPACITANCE VALUES ONE AND OVER IN PICOFARADS, LESS THAN ONE IN MICROFARADS
 7. ○ KNOB CONTROL
 8. ⊙ SCREWDRIVER CONTROL
 9. AT ANCHOR TERMINAL
 10. TP TEST POINT

	* C411	* C412	* C413
INSTRUMENT	C411	C412	C413
1617 50c LINE	.0243	.0243	.0475
1617 60c LINE	.02	.02	.04

Figure 6-11. Schematic diagram for the detector circuit.



MECHANICAL PARTS LIST

FIG	QNT	DESCRIPTION	GR PART NO	FMC	MFGR PART NO
1	1	HANDLE AND BRACKET ASM	1617-2010	24655	1617-2010
2	1	KNOB ASM D DIAL	5520-5520	24655	5520-5520
		INCLUDES			
2	1	RETAINER	5220-5401	24655	5220-5401
3	1	DIAL ASM D DIAL (115V 60HZ)	1617-1250	24655	1617-1250
3	1	DIAL ASM D DIAL (230V 50HZ)	1617-1260	24655	1617-1260
4	1	KNOB ASM GEN LEVEL MAX VOLTS	5500-5321	24655	5500-5321
		INCLUDES			
4	1	RETAINER	5220-5402	24655	5220-5402
5	1	INDICATOR D DIAL	5460-1303	24655	5460-1303
6	1	CABINET ASM (115V 60HZ)	1617-2001	24655	1617-2001
6	1	CABINET ASM (230V 50HZ)	1617-2002	24655	1617-2002
7	1	GASKET	5168-1470	24655	5168-1470
8	1	DIAL ASM METER (115V-60HZ)	1617-2170	24655	1617-2170
8	1	DIAL ASM METER (230V-50HZ)	1617-2190	24655	1617-2190
9	1	KNOB ASM METER	5500-5420	24655	5500-5420
		INCLUDES			
9	1	RETAINER	5220-5401	24655	5220-5401
10	1	DIAL ASM BIAS VOLTAGE RANGE	1617-2130	24655	1617-2130
11	1	KNOB ASM BIAS VOLTAGE RANGE	5520-5320	24655	5520-5320
		INCLUDES			
11	1	RETAINER	5220-5402	24655	5220-5402
12	1	DIAL ASM LEAK CURRENT RANGE	1617-2140	24655	1617-2140
13	1	KNOB ASM LEAK CURRENT RANGE	5520-5320	24655	5520-5320
		INCLUDES			
13	1	RETAINER	5220-5402	24655	5220-5402
14	1	KNOB ASM EXTERNAL BIAS	5520-5321	24655	5520-5321
		INCLUDES			
14	1	RETAINER	5220-5402	24655	5220-5402
15	1	KNOB ASM MULTIPLIER	5500-5420	24655	5500-5420
		INCLUDES			
15	1	RETAINER	5220-5401	24655	5220-5401
16	1	DIAL ASM MULTIPLIER	1617-2150	24655	1617-2150
17	1	KNOB ASM DETECTOR SENSITIVITY	5520-5321	24655	5520-5321
		INCLUDES			
17	1	RETAINER	5220-5402	24655	5220-5402
18	1	INDICATOR C DIAL	5460-1303	24655	5460-1303
19	1	DIAL ASM C DIAL	1617-1270	24655	1617-1270
20	1	KNOB ASM C DIAL	5520-5520	24655	5520-5520
		INCLUDES			
20	1	RETAINER	5220-5401	24655	5220-5401
21	1	GASKET	5168-0796	24655	5168-0796
22	4	FEEET	5260-0900	24655	5260-0900
23	2	PILOT LIGHT CAP	5620-0500	72765	25P UNFLUTED
24	1	COVER	4170-2086	24655	4170-2086
25	1	HOLDER, LAMP MARKED	5600-1023	24655	5600-1023



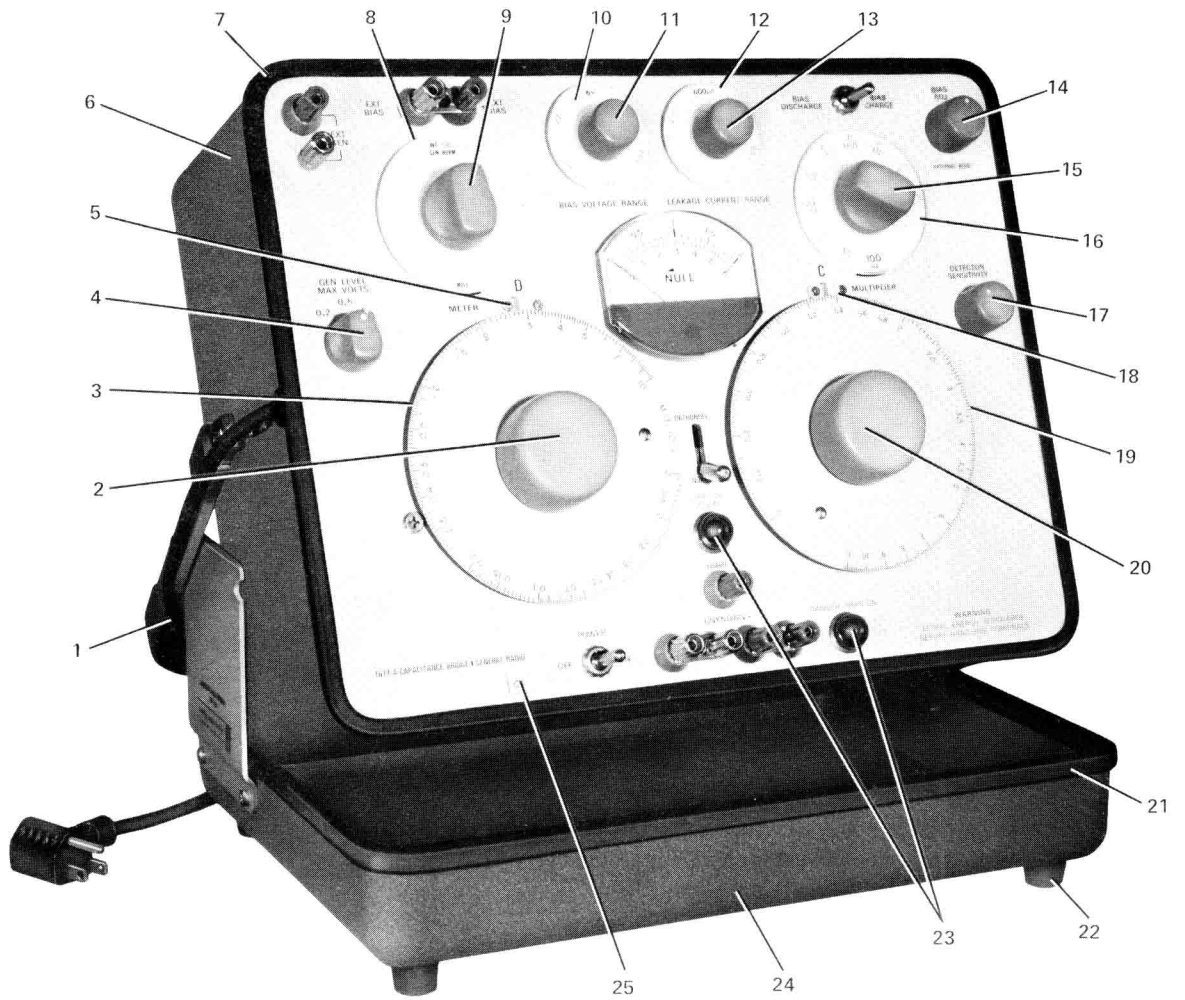

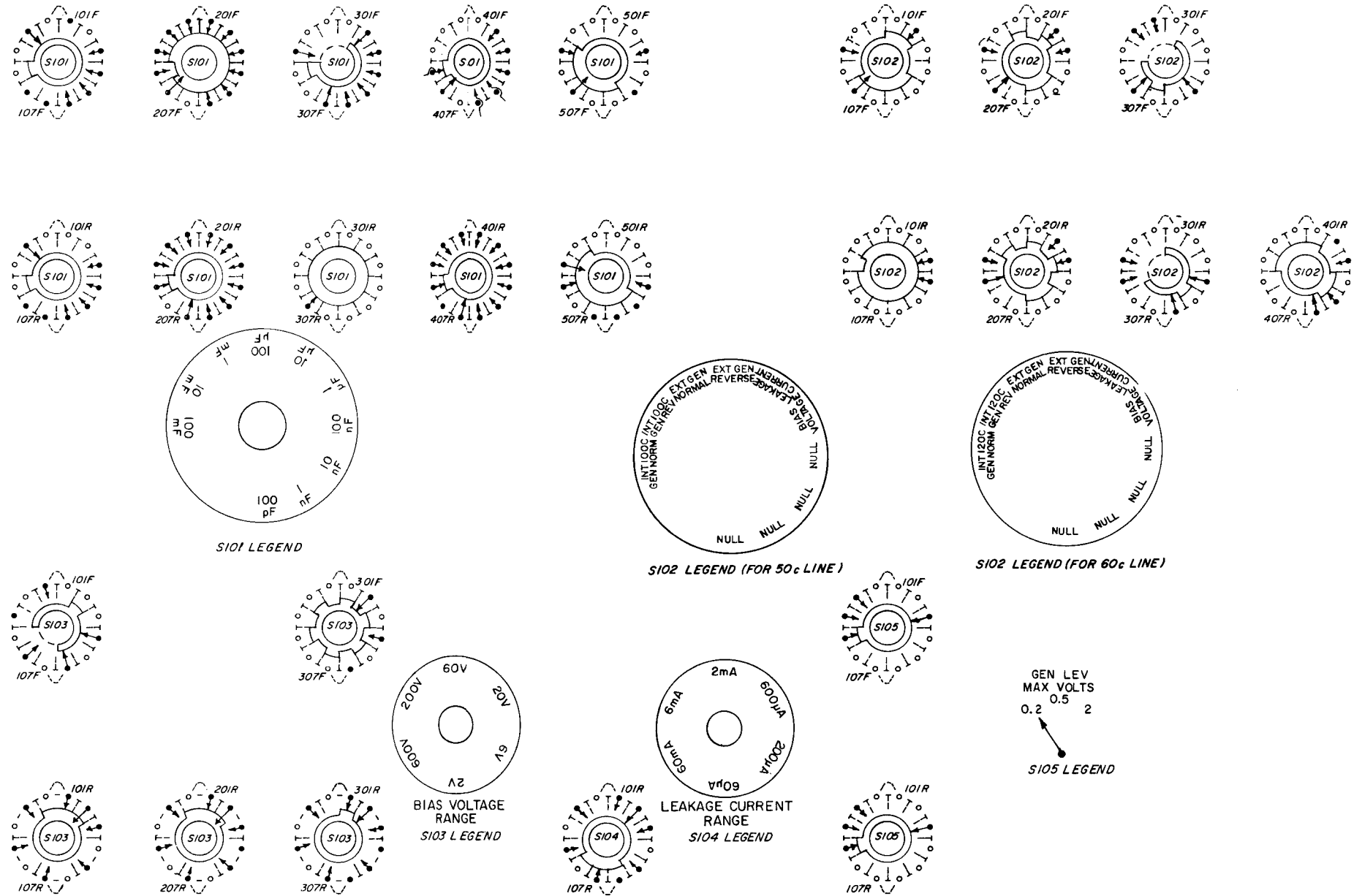

Rotary switch sections are shown as viewed from the panel end of the shaft. The first digit of the contact number refers to the section. The section nearest the panel is 1, the next section back is 2, etc. The next two digits refer to the contact. Contact 01 is the first position clockwise from a strut screw (usually the screw above the locating key), and the other contacts are numbered sequentially (02, 03, 04, etc), proceeding clockwise around the section. A suffix F or R indicates that the contact is on the front or rear of the section, respectively.

Figure 6-12. Switch diagram for Type 1617 front panel controls.



ELECTRICAL PARTS LIST

MAIN FRAME & SWITCH ASSEMBLIES

REFDES	DESCRIPTION	PART NO.	FMC	MFGR	PART NUMBER
R 113	RES FLM 20K 1 PCT 1/2W	6450-2200	81349		RN65D2002F
R 114	RES FLM 1.1K 1 PCT 1/2W	6450-1110	81349		RN65D1101F
R 115	RES COMP 160 OHM 5PCT 1/2W	6100-1165	81349		RCR20G161J
R 151	RES FLM 4.02K 1 PCT 1/8W	6250-1402	81349		RN55D4021F
R 152	RES FLM 14K 1 PCT 1/8W	6250-2140	81349		RN55D1402F
R 153	RES FLM 40.2K 1 PCT 1/8W	6250-2402	81349		RN55D4022F
R 154	RES FLM 140K 1 PCT 1/4W	6350-3140	81349		RN60D1403F
R 155	RES FLM 402K 1 PCT 1W	6550-3402	81349		RN75D4023F
R 156	RES WW AX LEAD 100 OHM 5 PCT 5W	6660-1105	75042		AS-5 100 OHM 5PCT
R 158	RES FLM 66.5K 1 PCT 1/2W	6450-2665	81349		RN65D6652F
R 159	RES FLM 232K 1 PCT 1/2W	6450-3232	81349		RN65D2323F
R 160	RES FLM 665K 1 PCT 1/2W	6450-3665	81349		RN65D6653F
R 161	RES FLM 2.32M 1 PCT 1/2W	6450-4232	81349		RN65D2324F
R 162	RES FLM 6.65M 1 PCT 1W	6550-4665	81349		RN75D6654F
R 163	RES FLM 30.1K 1 PCT 1/2W	6450-2301	81349		RN65D3012F
R 164	RES FLM 18.7K 1 PCT 1/2W	6450-2187	81349		RN65D1872F
R 165	RES FLM 976 OHM 1 PCT 1/2W	6450-0976	81349		RN65D9760F
R 166	RES FLM 261 OHM 1 PCT 1/2W	6450-0261	81349		RN65D2610F
R 167	RES FLM 68.1 OHM 1 PCT 1/2W	6450-9681	81349		RN65D68R1F
R 168	RES FLM 23.7 OHM 1 PCT 1/2W	6450-9237	81349		RN65D23R7F
R 169	RES FLM 10 OHM 1 PCT 1/8W	6250-9100	81349		RN55D10R0F
R 171	RES COMP 3.0 K OHM 5PCT 1/2W	6100-2305	81349		RCR20G302J
R 172	RES COMP 10 K 5PCT 1/2W	6100-3105	81349		RCR20G103J
R 173	RES COMP 30 K OHM 5PCT 1/2W	6100-3305	81349		RCR20G303J
R 174	RES COMP 100 K 5PCT 1/2W	6100-4105	81349		RCR20G104J
R 175	RES COMP 300 K OHM 5PCT 1/2W	6100-4305	81349		RCR20G304J
R 176	RES COMP 470 K 5PCT 1/2W	6100-4475	81349		RCR20G474J
R 177	RES COMP 470 K 5PCT 1/2W	6100-4475	81349		RCR20G474J
R 178	RES WW AX LEAD .47 OHM 10PCT 5W	6660-9047	75042		AS-5 0.47 OHM 5PCT
R 179	RES WW AX LEAD 1.8 OHM 5 PCT 5W	6660-9185	75042		AS-5 1.8 OHM 5PCT
R 180	RES WW AX LEAD 22 OHM 5 PCT 5W	6660-0225	75042		AS-5 22 OHM 5PCT
R 181	RES WW AX LEAD 200 OHM 5 PCT 5W	6660-1205	75042		AS-5 200 OHM 5PCT
R 183	POT WW TRM 1K OHM 10 PCT 1T	6050-1300	24655		6050-1300
R 184	THERMISTOR 50 OHM 10PCT	6740-1900	15801		CB15L1
R 187	RES WW MOLDED 4.7 OHM 10 PCT 2W	6760-9479	75042		BWH 4.7 OHM 10PCT
R 188	RES WW MOLDED 220 OHM 10 PCT 2W	6760-1229	75042		BWH 220 OHM 10PCT
S 101	SWITCH ROTARY ASM	7890-3790	24655		7890-3790
S 102	SWITCH ROTARY ASM	7890-3800	24655		7890-3800
S 103	SWITCH ROTARY ASM	7890-3810	24655		7890-3810
S 104	SWITCH ROTARY ASM	7890-3820	24655		7890-3820
S 105	SWITCH ROTARY ASM	7890-3830	24655		7890-3830
S 106	SWITCH TOGGLE 2POS DPDT STEADY	7910-1500	04009		83054
S 107	POT COMP KNOB 5K OHM 10PCT SW	6045-2510	24655		6045-2510
S 501	SWITCH TOGGLE 2POS DPST STEADY	7910-1300	04009		83053
T 101	TRANSFORMER BRIDGE	0746-4440	24655		0746-4440
T 102	TRANSFORMER INDUCTOR	0745-4130	24655		0745-4130
T 501	TRANSFORMER POWER	0345-4012	24655		0345-4012



ELECTRICAL PARTS LIST

MAIN FRAME & SWITCH ASSEMBLIES
 F501 & F502 (5330-0600) FOR 115V OPERATION
 F501 & F502 (5330-0400) FOR 230V OPERATION

REFDES	DESCRIPTION	PART NO.	FMC	MFR	PART NUMBER
C 101	CAPACITOR ASM 0.5 UF 1/4PCT 800V	0236-4050	24655		0236-4050
C 102	CAP ALUM 5000-2500-2500 UF 6V	4450-5608	56289		60D 6V
C 103	CAP ALUM 1500-750-750 UF 25V	4450-0700	56289		60D 25V
C 104	CAP ALUM 600-300-300 UF 75V	4450-5606	56289		60D 75V
C 105	CAP ALUM 300-150-150 UF 150V	4450-5602	56289		60D 150V
C 106	CAP ALUM 50-25-25 UF 450V	4450-0800	56289		60D 450V
C 107	CAP ALUM 50-25-25 UF 450V	4450-0800	56289		60D 450V
C 108	CAP ALUM 50-25-25 UF 450V	4450-0800	56289		60D 450V
C 109	CAP MYLAR .1UF 10 PCT 100V	4860-8250	56289		410P 0.1 UF 10PCT
C 110	CAP CER DISC 1000PF 10PCT 500V	4405-2108	72982		080108225F00102K
CR 101	RECT 1N4140 100PIV 3A SI 41XM	6081-1014	14433		1N4140
CR 102	RECT 1N4140 100PIV 3A SI 41XM	6081-1014	14433		1N4140
CR 103	DIODE RECTIFIER 1N4003	6081-1001	14433		1N4003
CR 104	DIODE RECTIFIER 1N4003	6081-1001	14433		1N4003
CR 105	DIODE RECTIFIER 1N4003	6081-1001	14433		1N4003
F 501	FUSE SLO-BLOW 2/10A 250V	5330-0600	75915	313	.200
F 501	FUSE SLO-BLOW 1/10A 250V	5330-0400	75915	313	.100
F 502	FUSE SLO-BLOW 2/10A 250V	5330-0600	75915	313	.200
F 502	FUSE SLO-BLOW 1/10A 250V	5330-0400	75915	313	.100
J 101	BINDING POST ASM	0938-4252	24655		0938-4252
J 102	BINDING POST ASM	0938-4252	24655		0938-4252
J 103	BINDING POST ASM	0938-3000	24655		0938-3000
J 104	BINDING POST ASM	0938-3000	24655		0938-3000
J 105	BINDING POST ASM	0938-3002	24655		0938-3002
J 106	BINDING POST ASM	0938-3003	24655		0938-3003
J 107	BINDING POST ASM	0938-3000	24655		0938-3000
J 108	BINDING POST ASM	0938-3002	24655		0938-3002
J 109	BINDING POST ASM	0938-3000	24655		0938-3000
M 101	METER	5730-1333	24655		5730-1333
P 101	LAMP FLANGE BASE 6V 0.2A 1000H	5600-0300	71744		CM-328
P 102	LAMP BAYONET BASE 2V .06A	5600-0800	24455		49
P 103	LAMP BAYONET BASE 6.3V	5600-0700	71744		44
PL 501	COPD 3WR 10A 120V US 5.5FTHAMMER	4200-1903	24655		4200-1903
P 101	POTENTIOMETER 22.6-23.4 K	0433-4130	24655		0433-4130
P 102	POTENTIOMETER 27 K 2PCT	0977-4100	24655		0977-4100
R 103	RESISTOR ASM .01 OHM 0.25PCT	1617-1190	24655		1617-1190
R 104	RESISTOR ASM 0.1 OHM 0.25PCT	1617-1180	24655		1617-1180
R 105	RESISTANCE UNIT 1 OHM	0500-0300	24655		0500-0300
R 106	RES FLM 10 OHM 1/4 PCT 1/2W	6452-9100	81349		RN65D10R0C
R 107	RES FLM 1000HM 1/10PCT 50PPM1/2W	6188-0100	81349		RN70C1000B
R 108	RES FLM 1 K 1/10PCT 50PPM1/2W	6188-1100	81349		RN70C1001B
R 109	RES FLM 10 K 1/10PCT 50PPM1/2W	6188-2100	81349		RN70C1002B
R 110	RES FLM 100 K 1/10PCT 50PPM1/2W	6188-3100	81349		RN70C1003B
P 111	RES FLM 1 M 1/10PCT 50PPM1/2W	6188-4100	81349		RN70C1004B
R 112	RES FLM 10M 1/4PCT 50PPM 2W	6195-5100	81349		RN80C1005C



SIG1 SECTION 2F CONNECTS ALL UNUSED .1710-ARMS RESISTORS TO GUARD(208F)

Figure 6-13. Over-all schematic diagram for the Type 1617 Capacitance Bridge.



NOTE: T501 FOR 115V CONNECT 1 TO 3 & 2 TO 4
 F501=0.2 AMP
 F502=0.2 AMP
 FOR 230V CONNECT 2 TO 3
 F501=0.1 AMP
 F502=0.1 AMP
 INPUT 115-230V 50C OR 60C

- NOTE UNLESS SPECIFIED
1. POSITION OF ROTARY SWITCHES SHOWN COUNTERCLOCKWISE.
 2. CONTACT NUMBERING OF SWITCHES EXPLAINED ON SEPARATE SHEET SUPPLIED IN INSTRUCTION BOOK.
 3. REFER TO SERVICE NOTES IN INSTRUCTION BOOK FOR VOLTAGES APPEARING ON DIAGRAM.
 4. RESISTORS 1/2 WATT.
 5. RESISTANCE IN OHMS K - 1000 OHMS M - 1 MEGOHM
 6. CAPACITANCE VALUES ONE AND OVER IN PICOFARADS, LESS THAN ONE IN MICROFARADS.
 7. KNOB CONTROL
 8. SCREWDRIVER CONTROL
 9. AT - ANCHOR TERMINAL
 10. TP - TEST POINT

ANCHOR TERMINALS USED: A.T.101-105

- | | | | | | |
|---------|----------------------|----------------------|--------|---------|-------|
| ● 100pF | ● EXT GEN REVERSE | ● EXT GEN REVERSE | ● 2V | ● 60µA | ● 0.2 |
| ● 1nF | ● EXT GEN NORMAL | ● EXT GEN NORMAL | ● 6V | ● 200µA | ● 0.5 |
| ● 10nF | ● INT. 100C GEN REV | ● INT. 120C GEN REV | ● 20V | ● 600µA | ● 2 |
| ● 100nF | ● INT. 100C GEN NORM | ● INT. 120C GEN NORM | ● 60V | ● 2mA | |
| ● 1µF | ● BIAS VOLTAGE | ● BIAS VOLTAGE | ● 200V | ● 6mA | |
| ● 10µF | ● LEAKAGE CURRENT | ● LEAKAGE CURRENT | ● 600V | ● 60mA | |
- S102 LEGEND (50C LINE) S102 LEGEND (60C LINE) S103 LEGEND S104 LEGEND S105 LEGEND

APPENDIX



PRECISION DECADE CAPACITOR

Type 1423-A

This capacitor is a versatile tool for calibration laboratories and production-line testing. With it a bridge can be standardized to an accuracy exceeded only by that of the highest quality, individually certified laboratory standards.

Any value of capacitance from 100 pF to 1.111 μ F, in steps of 100 pF, can be set on the four decades and will be known to an accuracy of 0.05%.

Catalog Number	Description
1423-9801	Precision Decade Capacitor 1423-A, Bench Model
1423-9811	1423-A, Rack Model

STANDARD CAPACITOR

Type 1409



Catalog Number	Type	Nominal Capacitance μ F	Frequency Limit for Max Volts
1409-9706	1409-F	0.001	4.7 MHz
1409-9707	1409-G	0.002	2.7 MHz
1409-9711	1409-K	0.005	1.3 MHz
1409-9712	1409-L	0.01	750 kHz
1409-9713	1409-M	0.02	430 kHz
1409-9718	1409-R	0.05	210 kHz
1409-9720	1409-T	0.1	120 kHz
1409-9721	1409-U	0.2	70 kHz
1409-9724	1409-X	0.5	35 kHz
1409-9725	1409-Y	-1.0	17 kHz

The 1409 Standard Capacitors are fixed mica capacitors of very high stability for use as two- or three-terminal reference or working standards in the laboratory.

DECADE RESISTOR

Type 1433

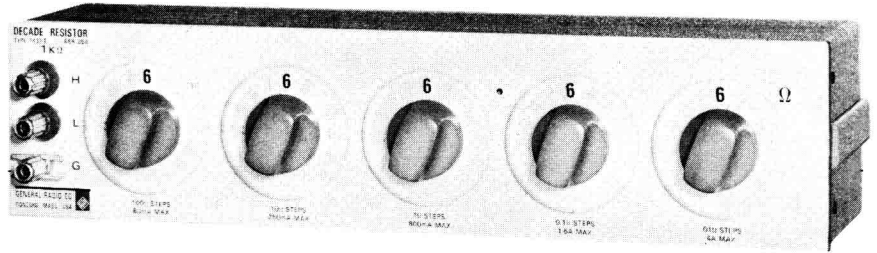

- $\pm 0.02\%$ accuracy
- good frequency characteristics
- low temperature coefficient
- excellent stability
- low zero resistance

The 1433 Decade Resistors are primarily intended for precision measurement applications where their excellent accuracy, stability, and low zero resistance are important. They are convenient resistance standards for checking the accuracy of resistance-measuring devices and are used as components in dc and audio-frequency impedance bridges.

Catalog Number		Type	Total Ohms	Ohms per Step	No. of Dials
Bench	Rack				
1433-9700	1433-9701	1433-U	111.1	0.01	4
1433-9702	1433-9703	1433-K	1111	0.1	4
1433-9704	1433-9705	1433-J	11,110	1	4
1433-9706	1433-9707	1433-L	111,100	10	4
1433-9708	1433-9709	1433-Q	1,111,000	100	4
1433-9710	1433-9711	1433-T	1111.1	0.01	5
1433-9712	1433-9713	1433-N	11,111	0.1	5
1433-9714	1433-9715	1433-M	111,110	1	5
1433-9716	1433-9717	1433-P	1,111,100	10	5
1433-9718	1433-9719	1433-Y	11,111,000	100	5
1433-9720	1433-9721	1433-W	11,111.1	0.01	6
1433-9722	1433-9723	1433-X	111,111	0.1	6
1433-9724	1433-9725	1433-B	1,111,110	1	6
1433-9726	1433-9728	1433-Z	11,111,100	10	6
1433-9729	1433-9730	1433-F	111,111.1	0.01	7
1433-9731	1433-9732	1433-G	1,111,111	0.1	7
1433-9733	1433-9734	1433-H	11,111,110	1	7

TEST JIG

Type 1650-P1

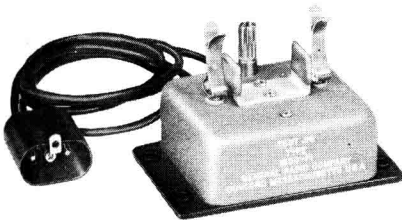

This test-jig adaptor is used to connect components quickly to a pair of terminals and can be placed on the bench directly in front of the operator.

The test jig makes a three-terminal connection to the bridge, so that the residual zero capacitance is negligible.

The lead resistance (0.08 ohm total) has effect only when very low impedances are measured, and the lead capacitance affects only the measurement of the Q of inductors, introducing a small error in D (or $\frac{1}{Q}$) of less than 0.007.

Catalog Number	Description
1650-9601	1650-P1 Test Jig

GENERAL RADIO COMPANY

WEST CONCORD, MASSACHUSETTS,* 01781

617 369-4400

617 646-7400

SALES ENGINEERING OFFICES

METROPOLITAN NEW YORK*

*Broad Avenue at Linden
Ridgefield, New Jersey, 07657
Telephone N.Y. 212 964-2722
N.J. 201 943-3140*

SYRACUSE

*Pickard Building
East Molloy Road
Syracuse, New York, 13211
Telephone 315 454-9323*

PHILADELPHIA

*1150 York Road
Abington, Pennsylvania, 19001
Telephone 215 887-8486
Phila., 215 424-7419*

WASHINGTON* and BALTIMORE

*Rockville Pike at Wall Lane
Rockville, Maryland 20852
Telephone 301 946-1600*

ORLANDO

*113 East Colonial Drive
Orlando, Florida, 32801
Telephone 305 425-4671*

CHICAGO*

*6605 West North Avenue
Oak Park, Illinois, 60302
Telephone 312 848-9400*

CLEVELAND

*5579 Pearl Road
Cleveland, Ohio, 44129
Telephone 216 886-0150*

LOS ANGELES*

*1000 North Seward Street
Los Angeles, California, 90038
Telephone 213 469-6201*

SAN FRANCISCO

*1186 Los Altos Avenue
Los Altos, California, 94022
Telephone 415 948-8233*

DALLAS

*2501 -A West Mockingbird Lane
Dallas, Texas, 75235
Telephone 214 Fleetwood 7-4031*

TORONTO*

*99 Floral Parkway
Toronto 15, Ontario, Canada
Telephone 416 247-2171*

MONTREAL BRANCH

*Office 395, 1255 Laird Boulevard
Town of Mount Royal, Quebec, Canada
Telephone 514 737-3673, -3674*

* Repair services are available at these offices.

*General Radio Company (Overseas), Zurich, Switzerland
General Radio Company (U.K.) Limited, Bourne End, Buckinghamshire, England
Representatives in Principal Overseas Countries*

