

OPERATING INSTRUCTIONS
FOR
TYPE 726-A VACUUM-TUBE VOLTMETER

GENERAL RADIO COMPANY
CAMBRIDGE 39, MASSACHUSETTS





OPERATING INSTRUCTIONS

FOR

TYPE 726-A

VACUUM-TUBE VOLTMETER

Form 626-A

GENERAL RADIO COMPANY
CAMBRIDGE 39, MASSACHUSETTS



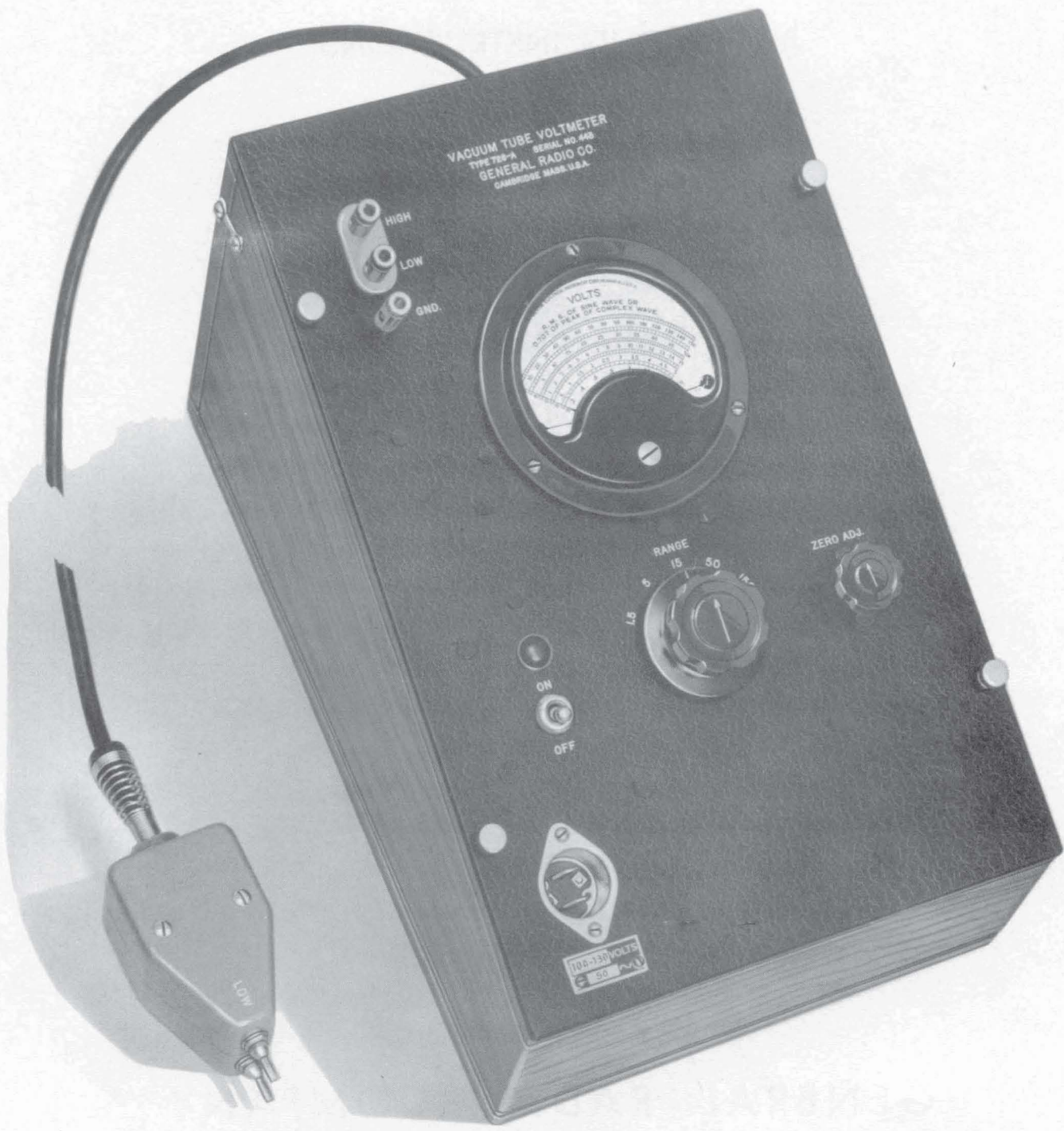

OPERATING INSTRUCTIONS
FOR
TYPE 726-A VACUUM-TUBE VOLTMETER

PART 1
DESCRIPTION

1.1 PURPOSE

The Type 726-A Vacuum-Tube Voltmeter is a high-impedance wide-range voltmeter for use at both audio and radio frequencies. Its upper frequency limit is in the vicinity of 100 megacycles.

It is essentially a peak reading instrument, except on the two lowest voltage ranges, but the scale is calibrated to give readings of the r-m-s values of sinusoidal applied voltages.

1.2 USE AS A RADIO-FREQUENCY AMMETER

In addition to its use as a voltmeter, it can be used to measure current at radio frequencies with a capacitive shunt. Used in this way, it provides a convenient method of measuring antenna current.

1.3 CIRCUIT

A diode-condenser rectifier circuit, using an acorn tube, is built into a small probe which is made of low-loss bakelite. A cable, which also supplies heater voltage to the tube in the probe, carries the rectified voltage to a d-c amplifier and indicating meter in the cabinet of the instrument.

The d-c amplifier is of the degenerative type using but one tube. The rectified voltage is applied directly to the amplifier control grid, rather than through a voltage-dividing network, and the change from one voltage range to another is accomplished by varying the degeneration factor.

The schematic circuit diagram shows this circuit in elementary form. A complete wiring diagram, with parts list, is given in Part 4.

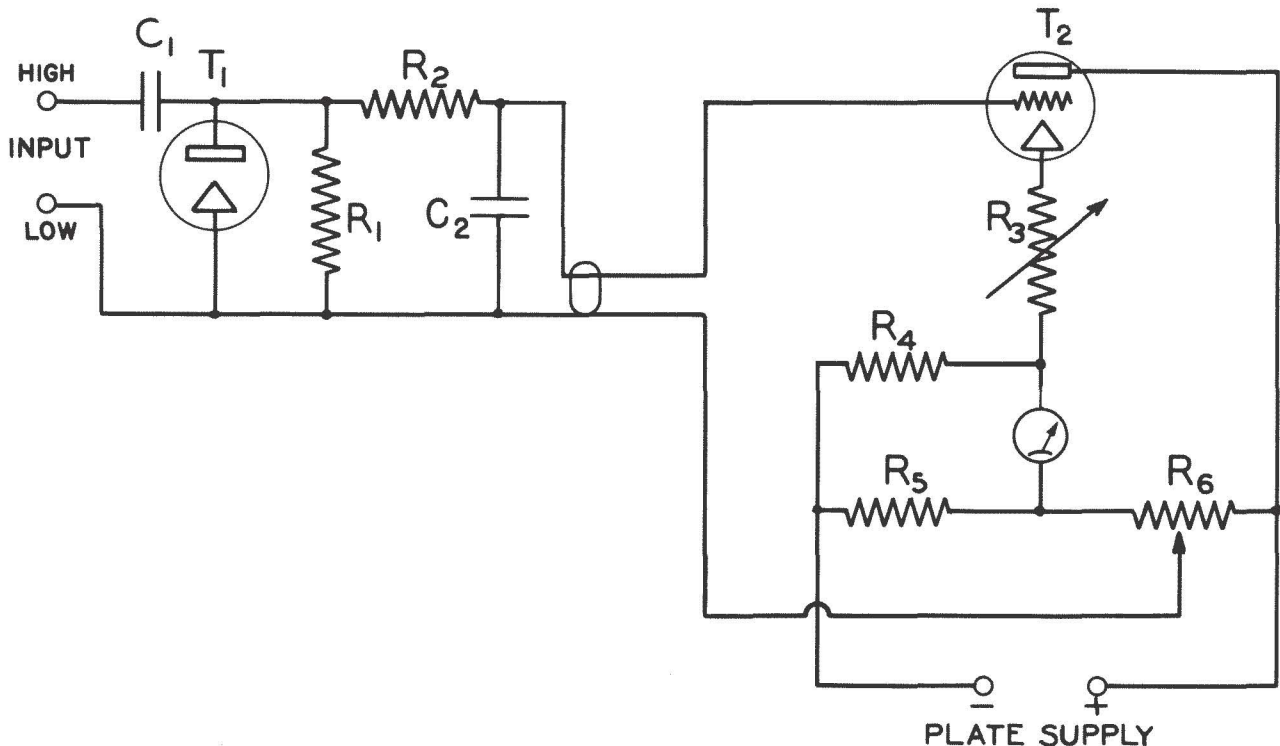

GENERAL RADIO COMPANY

PART 2 OPERATING CHARACTERISTICS

2.1 RANGE

0.1 to 150 volts ac, in five ranges (1.5, 5, 15, 50, 150 volts, full scale). The range can be extended to 1500 volts by means of the Type 726-P1 Multiplier.

2.2 ACCURACY

$\pm 2\%$ of full scale on all five ranges, on sinusoidal voltages.

2.3 WAVEFORM ERROR

The instrument is essentially a peak voltmeter calibrated to read r-m-s values of a sine wave, or 0.707 of the peak value of a complex wave. On distorted waveforms the percentage deviation of the reading from the r-m-s value may be as large as the percentage of harmonics present.

2.4 FREQUENCY ERROR

At high frequencies resonance in the input circuit and transit-time effects in the diode rectifier introduce errors in the meter reading. The resonance effect causes the meter to read high and is independent of the applied voltage. The transit-time error, on the other hand, is a function of the applied voltage and tends to cause the meter to read low. The accompanying curve gives the frequency correction for several differ-

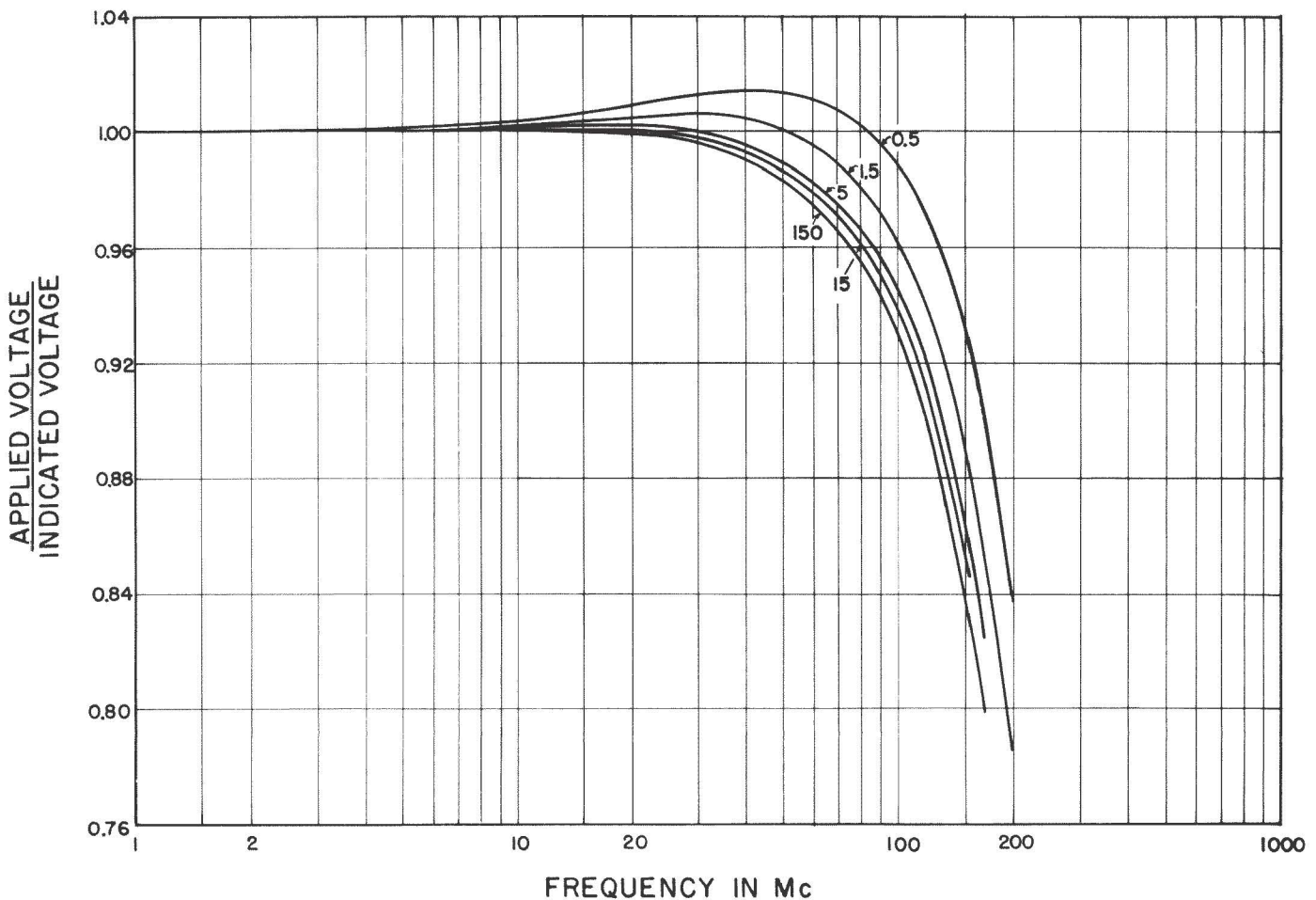

GENERAL RADIO COMPANY

ent voltage levels. It will be noted that at low voltages the transit-time and resonance effects tend to cancel, while at the higher voltages the error is almost entirely due to resonance.

At the low audio-frequency end, this voltmeter may be used at frequencies as low as 20 cycles with an error of less than 1%. Typical measured errors are as follows:

<u>Frequency</u>	<u>Error</u>
20 cycles	-0.5%
14 cycles	-2%
10 cycles	-4%

2.5 INPUT IMPEDANCE

The input circuit is equivalent to a resistance of 6 megohms in parallel with 6.6 μf . At the higher frequencies the effective parallel resistance is reduced by losses in the shunt capacitance. The accompanying plot gives the variation of R_p and X_p with frequency.

2.6 TEMPERATURE AND HUMIDITY EFFECTS

Over the normal range of room conditions (65° Fahrenheit to 95° Fahrenheit; 0 to 95% relative humidity) the accuracy is substantially unaffected by temperature and humidity conditions.

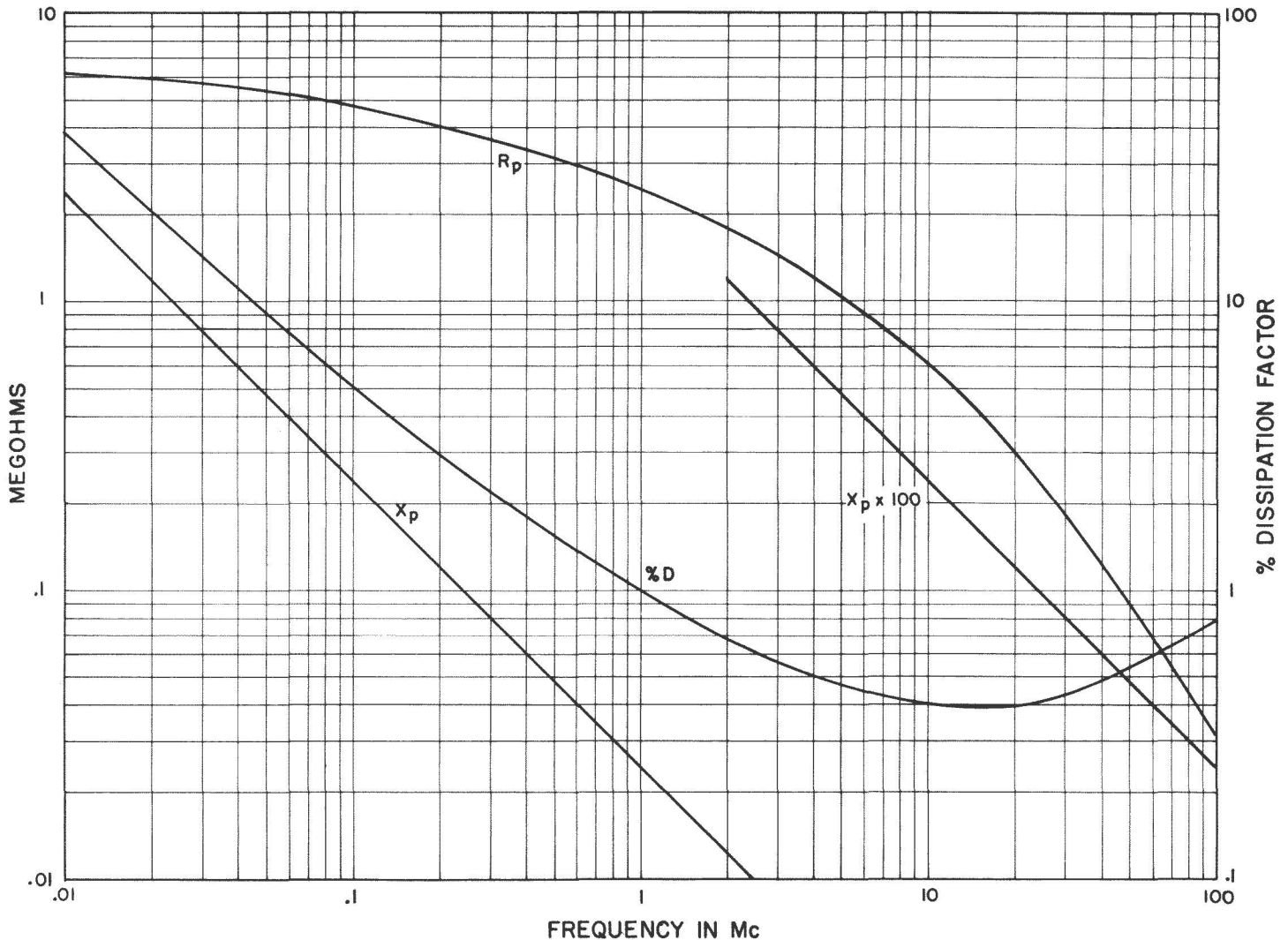

GENERAL RADIO COMPANY

2.7 POWER SUPPLY

100 to 130 volts ac, 60, 50, or 42 cycles and 200 to 260 volts, 50 cycles. The instrument incorporates a voltage regulator to compensate for supply variations over this voltage range. The power input is less than 30 watts. Line voltage and frequency are engraved on a plate under the POWER INPUT socket.

2.8 TUBES

One Type 955, one Type 6Q7-G, and one Type 1-V are used; all are supplied.

2.9 ACCESSORIES SUPPLIED

A seven-foot line connector cord, spare pilot lamps and fuses.

2.10 MOUNTING

Black crackle-finish aluminum panel mounted in a shielded walnut cabinet.

2.11 DIMENSIONS

(Width) 9-1/2 x (depth) 14 x (height) 8-1/2 inches, overall.

2.12 NET WEIGHT

17-1/2 pounds.

PART 3 OPERATING INSTRUCTIONS

3.1 POWER SUPPLY

Connect the voltmeter to the a-c line by means of cord and plug provided. Be sure that the voltage and frequency of the power line correspond to those engraved on the plate under the POWER INPUT socket.

3.2 ZERO SETTING

Short circuit the HIGH and LOW terminals, and vary the ZERO ADJUST knob until the meter reads zero.

3.3 MEASUREMENTS

Voltages may be measured at the panel terminals with the probe in place at the rear of the cabinet or at the probe terminals with the probe removed from the cabinet. The LOW terminal is grounded to the panel through a 0.02 μ f condenser and may be directly grounded at the panel terminal "G" if so desired.

The instrument indicates the voltage actually appearing at the cathode and plate of the 955-type rectifier tube in the probe. At high radio frequencies, therefore, care should be taken not to place the cable too close to the voltage source, as standing waves may be set up in the shield, resulting in voltage being transferred backward to the input terminals.

The d-c voltage between the LOW input and GND should not exceed 400 volts.

PART 4 MAINTENANCE

4.1 VACUUM-TUBE REPLACEMENTS

Replacement of either the Type 955 or Type 6Q7-G Tube will, in general, require re-adjustment of the movable contacts A₁, A₂, A₃, A₄ and A₅ on resistors R₁₂, R₁₄, and R₂₄ to make the zero settings coincide on the different ranges. To make this adjustment the instrument must be removed from the cabinet and the respective contacts adjusted until the zero reading is the same for all 5 ranges. Then after the instrument is replaced in the cabinet, the external zero adjustment will bring all ranges to zero at the same point.



GENERAL RADIO COMPANY

Replacement of the Type 955 or Type 6Q7-G Tube will cause no substantial change in the calibration except possibly for the 1.5-volt range where a readjustment of resistor R₁₈ will correct any error. This is a screw-driver adjustment on the card mounted on the meter. If either tube is abnormally gassy, however, the calibration may be affected appreciably.

To open the probe for replacing the 955-type tube, remove the two flat-head screws and the plug terminal with its hexagonal insert on the LOW side of the probe. Do not attempt to remove the insert on the HIGH side.

4.2 METER

4.21 Sticky Meter: Extremes of temperature and humidity may cause the pivots to stick in the meter bearings. A person skilled in meter work may open the case and loosen either bearing. Otherwise, the meter should be returned to the Service Department for repair or replacement.

4.22 Changes in Meter Sensitivity: Although this trouble is rare, ageing might cause changes in sensitivity. The meter should be returned to the Service Department.

4.23 The voltmeter tube will occasionally affect the meter linearity.

4.24 When the shield of the shielded cable that connects the probe to the instrument becomes broken (this might happen where it is soldered to probe), the meter will read full scale with the probe removed and the zero will not remain set with the probe in place.

4.25 When the cathode circuit of the voltmeter tube is open, the meter will stay at extreme full scale, and the source of the open circuit can easily be located by observing which scale is affected. (Resistors R-1 to R-6 and R-8 to R-22 most usually open circuit).

4.26 Inability to Set Zero on 1.5-Volt Scale, or Wandering of Meter Needle:

4.261 After trying a new voltmeter tube, try changing the 955 acorn tube in the probe.

4.27 Meter Backing Off Scale

4.271 An open in the plate circuit of the voltmeter tube.

4.272 Burned-out 955 tube in probe.

4.273 No filament on 955 tube, or

4.274 Open 10-megohm resistor, R-16, in probe.

4.28 Needle Vibrates on the 1.5-Volt Scale, as if A-C Were Getting Into Meter

4.281 Panel light or filament of 1-V (rectifier) tube grounded to panel.

4.282 Filter condenser, C-1 (1 μ f) leaking between terminals or to ground.

4.29 Meter Reading Up Scale or Appearing Erratic on the 1.5-Volt Scale

4.291 This is due to the 50-megohm resistor, R-17, open circuiting. This is located inside the probe.

4.3 ERRORS BECAUSE OF D-C IN VOLTAGE BEING MEASURED

4.31 Condensers C₄ and C₅ located in the PROBE might possibly develop leakage resulting in changes in reading because of direct current in the input voltage.

4.32 These condensers should be replaced if their leakage resistance is less than 20,000 megohms. Instruments tested in our laboratory give less than 0.3-volt deflection when 45 volts d-c are applied across the HIGH and LOW terminals (+ to LOW) for a period of about one minute.



GENERAL RADIO COMPANY

4.4 VOLTAGE ACROSS CONDENSER C-1

4.41 This should be between 325 and 375 volts d-c.

4.5 WIRING AND CONNECTIONS

4.51 The wiring may become displaced and should be checked if any difficulty with the instrument develops.

4.52 Connections should be inspected and, if necessary, resoldered.

4.6 VOLTAGE BETWEEN LOW AND GND.

If one side of condenser C₁ short circuits to the case, a voltage will be present between the LOW terminal and GND. The condenser should be replaced.

4.7 TUBE DATA

4.71 Foreword: These data were measured in the Calibrating Laboratory of the General Radio Company using a Model 772 Weston Analyzer for the a-c and d-c measurements of all tube voltages and currents. Similar instruments may be used for checking in the field, but care should be taken to see that voltmeters used have a relatively high impedance, say 1000 ohms per volt or better.

Values as tabulated were obtained from standard instruments that were being calibrated for stock. Variations between instruments as great as 10% or 15% are normal.

4.72 Operating Conditions: Line voltage, 115 volts (230 for 50-cycle model); frequency either 42, 50 or 60 cycles, depending on the model; RANGE switch set to 150; no input signal.

	Type of Tube	Heater	Plate to Cathode	*Grid to Cathode	Plate Current
T1	RCA 75 or RCA 6Q7-G	5.0 v rms	100 v d-c	-.5 v d-c	.25 ma
T2	RCA 1-V	6.4 v a-c	370 v d-c	---	5.8 ma
T3	RCA 955	5.5 v rms	---	---	---

*Measured with 200,000-ohm voltmeter.

For the different positions of the RANGE switch, the voltage and current conditions for the Type 75 or 6Q7-G Tube change as follows. Other operating conditions are as above.

Range	Plate to Cathode	*Grid to Cathode	Plate Current
1.5	330 v d-c	-.5 v d-c	.42 ma
5.	320 v d-c	-.8 v d-c	.42 ma
15.	290 v d-c	-1.1 v d-c	.42 ma
50.	255 v d-c	-1.3 v d-c	.25 ma
150.	100 v d-c	-.5 v d-c	.25 ma

*Measured with 200,000-ohm voltmeter.



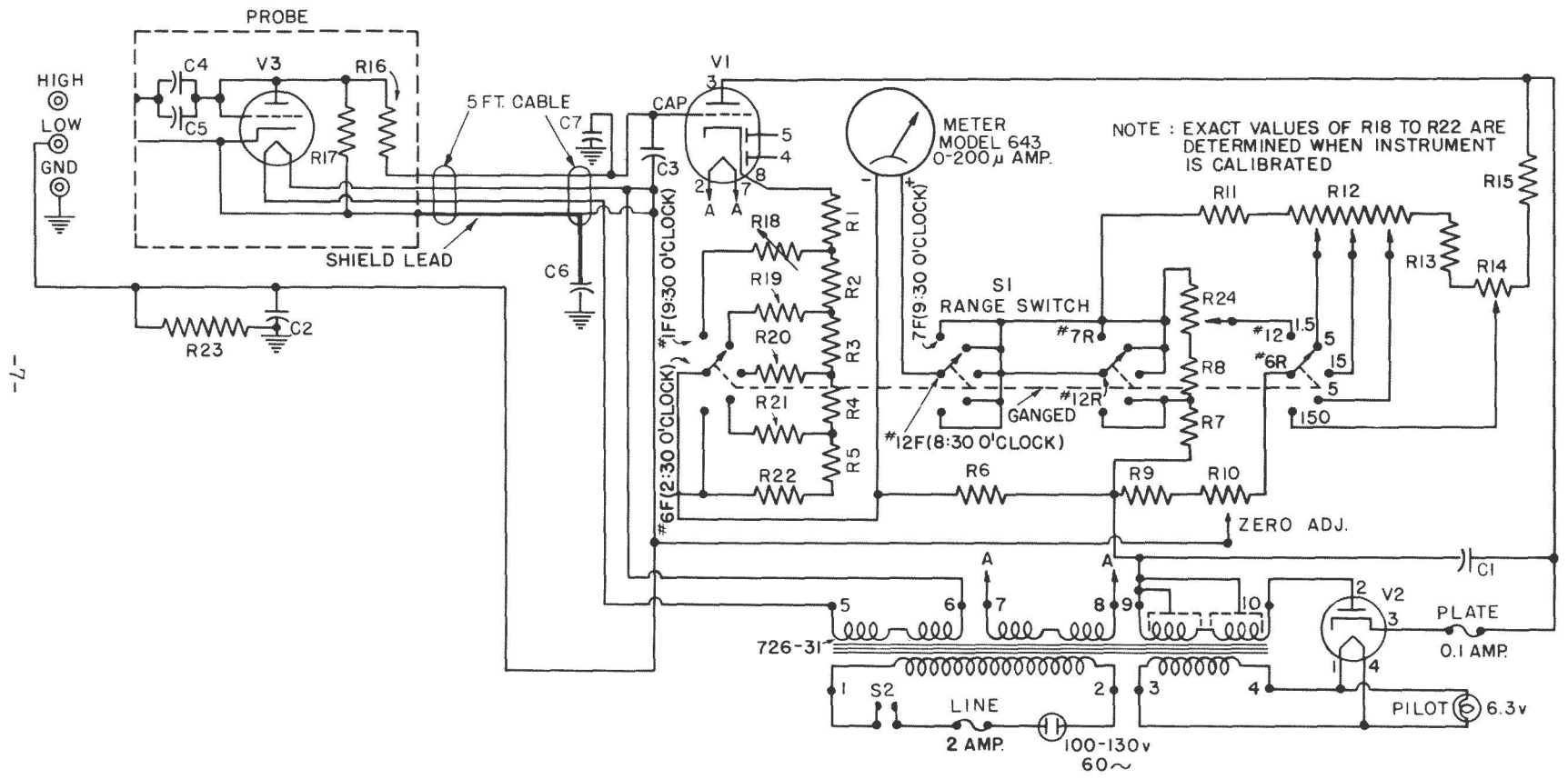

Wiring Diagram for Type 726-A Vacuum-Tube Voltmeter



GENERAL RADIO COMPANY

PARTS LIST FOR TYPE 726-A VACUUM-TUBE VOLTMETER

Symbol	Rating and Tolerance	Manufacturer	Mfr's. Type No.	General Radio Type or Dwg. No.
<u>Resistors</u>				
R-1	4000 $\Omega \pm 0.2\%$	IRC	WW-3	
R-2	20,150 $\Omega \pm 0.2\%$	IRC	WW-3	
R-3	59,000 $\Omega \pm 0.2\%$	IRC	WW-3	
R-4	220,000 $\Omega \pm 0.2\%$	IRC	WW-4	
R-5	630,000 $\Omega \pm 0.2\%$	IRC	WW-5	
R-6	50,000 $\Omega \pm 1\%$	IRC	WW-3	
R-7	2245 $\Omega \pm 1\%$	IRC	WW-3	
R-8	990 $\Omega \pm 1\%$	IRC	WW-3	
R-9	0.5 M $\Omega \pm 5\%$	IRC	BT-1	
R-10	20,000 $\Omega \pm 10\%$, variable	GR	301-A	
R-11	1100 $\Omega \pm 1\%$	IRC	WW-3	
R-12	14,900 $\Omega \pm 2\%$	GR	154-401	
R-13	15,000 $\Omega \pm 1\%$	IRC	WW-3	
R-14	20,000 $\Omega \pm 2\%$	GR	301-411	
R-15	9000 $\Omega \pm 1\%$	IRC	WW-3	
R-16	12 M $\Omega \pm 20\%$	IRC	FX-1/2	
R-17	60 M $\Omega \pm 20\%$	IRC	FX-1/2	
R-18 } to } R-22 }	Values determined at time of calibration.	GR	726-370	726-4
R-23		10 M Ω	IRC	BT-1
R-24		500 $\Omega \pm 2\%$	GR	301-427-2
<u>Capacitors</u>				
C-1	1.0 microfarad	Dubilier		139-1111
C-2	0.02 microfarad	Dubilier	Type 4	
C-3	Same as C-2			
C-4	0.01 microfarad (leakage resistance must measure 20,000 M Ω or greater on G-R Type 544-B Megohm Bridge)	Dubilier	Type 3L-5S1	
C-5	Same as C-4			
C-6	100 micromicrofarads	Micamold	Type S	
C-7	Same as C-6			
<u>Tubes</u>				
V-1	Amplifier	RCA	6Q7G	
V-2	Rectifier	RCA	1-V	
V-3	Diode	RCA	955	
<u>Switches</u>				
S-1	Range Switch	Oak	3955-E2	
S-2	Power Switch			SWT-323
<u>Meter</u>				
	0-200 microamperes, special scale	Weston	643	
<u>Fuses</u>				
	Line Fuse - 2 amp. Plate Fuse - 0.1 amp.	Bussmann Bussmann	7AG 7AG	
<u>Pilot Lamp</u>				
	Pilot Lamp - 6.3 volt			2LAP-330





