

in the field at the end of a power line. The secret of its superior performance is the sensing and control system — a servomechanism, rather than the relays that most other types use.

**Variac® Autotransformers** occupy our next panel — you can buy variable autotransformers from several manufacturers, but only Variac® has *Duratrak*, the stabilized brush-track surface. *Duratrak* is the most significant advance since the original variable autotransformer was invented by General Radio in 1933. It truly makes the variable autotransformer as durable as a fixed-ratio transformer.

We have operated *Duratrak*-treated models side by side with untreated brush-track types (our own as well as other makes) on severe short-period overload tests, with output currents many times their normal ratings. *In every case*, *Duratrak* models are unharmed when untreated types burn out.

Next, **parts** — General Radio quality parts are justly famous — knobs, dials, potentiometers, air capacitors, transformers, connectors, binding posts, and chokes — all are designed for instrument use; all are used in our own instruments.

And, speaking of dials, don't miss the motor drive for precision dials shown on the new TYPE 1304-B **Beat-Frequency Oscillator** on the table at the front of our booth. The TYPE 1304-B is the latest model of the popular General Radio beat-frequency oscillator. New features: an output voltmeter; additional 20 kc to 40 kc range; new output amplifier using the single-ended, push-pull circuit.

Many General Radio instruments not actually displayed are illustrated in our exhibit by color transparencies. Ask our engineers about them. Bring us your measurement problems; we shall do our best to help you solve them.

## THE COMPARISON BRIDGE

### A VERSATILE PRODUCTION-TEST INSTRUMENT



The inclusion of a 400-cycle test frequency makes the new TYPE 1604-B Comparison Bridge even more useful than its predecessor.<sup>1</sup> This versatile instrument, which combines the accuracy of a laboratory bridge with the speed required for production testing, has met with ready acceptance in the electrical and electronics industries, as well as in a number of other fields where its immediate application is not so evident.

<sup>1</sup>M. C. Holtje, "A New Comparison Bridge for the Rapid Testing of Components," *General Radio Experimenter*, Vol. XXVII, p. 7, December, 1952.

Figure 1. Panel view of the Type 1604-B Comparison Bridge.



The TYPE 1604-B Comparison Bridge uses a precision potentiometer in the ratio arms for changing the bridge ratio by  $\pm 20$  per cent from unity, and a differential capacitor for balancing the dissipation factor difference. A range switch shunts the precision potentiometer to provide a  $\pm 5$  per cent range for the most precise comparisons. Figure 2 is an elementary schematic diagram of the circuit.

Careful design and manufacture have made possible a superior degree of performance, in accuracy, sensitivity, stability, and range. The basic accuracy of 0.1 per cent is maintained over an impedance range of 2 ohms to 20 megohms.

The design and manufacturing features that contribute to this performance have been discussed in a previous article.<sup>1</sup>

### THREE TEST FREQUENCIES

The two test frequencies, 1 kc and 5 kc, on the original bridge, made possible somewhat greater ranges of measurement than would be possible with a single frequency, and, in addition, the 5 kc frequency is useful in showing up the effect of differences in distributed capacitance of coils. The 400-cycle test frequency now available in the new model is useful in measuring high-inductance coils whose apparent inductance, even at 1000 cycles, might be affected by the distributed capacitance. It is also useful for those measurements which must be made in accordance with test codes that specify 400 cycles.

Measurement at these frequencies avoids the possibility of errors resulting from 60-cycle hum pickup, which can be serious when the measurement frequency is 60 cycles, particularly in the measurement of coils and small capacitors.

<sup>1</sup>Loc. cit.

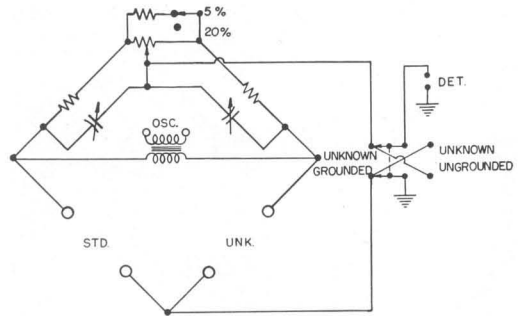

Figure 2. Elementary schematic circuit diagram of the bridge.

### TWO METHODS OF USE

An outstanding feature of the Comparison Bridge is its adaptability to either direct measurement or high-speed sorting. In direct measurement, the unknown is compared against a suitable standard, the bridge dials being rotated until the cathode-ray tube indicates a null. The difference between standard and unknown is then indicated by the dial settings. For high-speed sorting, the cathode-ray tube can be calibrated at the desired sorting tolerance and used to give a continuous "go, no-go" indication.

The rapid, no-overshoot response of the cathode-ray null indicator is particularly valuable in this kind of testing.

### AUTOMATIC SORTING

An interesting application of automatic-sorting technique is shown in Figure 3 where the Comparison Bridge is used for automatic sorting of capacitors in project "Tinkertoy." Capacitors from a hopper are fed past the unknown terminals of the bridge. They are measured and sorted automatically into one of three bins according to their value, at a rate of two per second.

The large error signal available at the plates of the cathode-ray indicator can be used in many ways to operate auto-





Figure 3. PROJECT TINKERTOY is the code name assigned to a program conceived and developed by the National Bureau of Standards for the Navy Bureau of Aeronautics, which involved the Modular Design of Electronics (MDE) and the Mechanized Production of Electronics (MPE).

More than 20 machines are utilized to produce electronic subassemblies automatically. Uniformity and reliability of product is achieved by employing automatic 100 percent inspection at nearly every station in the production process. This photograph shows equipment used in automatic inspection of titanate capacitors for specific capacity value. Type 722 Precision Capacitors with a range of from 110 to 1100 micromicrofarads and a Type 1604 Comparison Bridge are incorporated in the inspector. One of the precision capacitors is set at the upper tolerance limit of the required capacity, and the other is set at the lower tolerance. As the titanate bodies exit from the vibrator feeder, all silvered surfaces are checked for continuity. The capacitor is then automatically released and falls into the inspection circuit containing the precision capacitors and comparison bridge. The output of the bridge controls three inspection circuits: one to reject those capacitors that are above the upper tolerance, another to reject those bodies below the lower tolerance, and the final circuit to accept the capacitors that fall within the required tolerances. The automatic inspection of a single capacitor can be accomplished in less than half a second.

matic equipment limited only by the ingenuity of the designer.

One of the simplest methods to operate automatic equipment is shown in Figure 4. In this circuit, the error voltage is rectified and used to bias a thyatron to cut-off. If the unknown component is within tolerance, the bias will be reduced to the point where the thyatron will operate the relay. Sufficient sensitivity is available to select components within 0.02 per cent of the desired value. The gain control on the bridge can be used

to decrease this sensitivity to sort to any tolerance. A simple circuit like this operates on the magnitude of the error signal and will reject components if either the impedance or dissipation factor is outside the limit set.

### STANDARD

For production testing, the standard need not be a precision laboratory standard, but can be a component, similar to those being checked, which has been measured independently. A standard

Figure 4. Simple circuit for operating automatic sorting equipment.

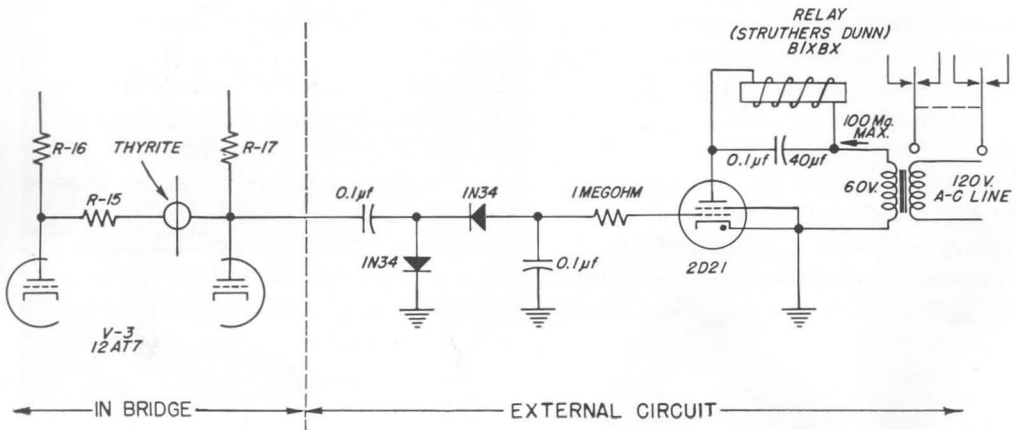



precisely at the desired value is not necessary, since an offset zero is provided within the bridge. Thus, if  $\pm 2$  per cent resistors are being sorted and the available standard is off 1.3 per cent, the bridge zero can be offset exactly 1.3 per cent and the resistors checked as if a perfect standard were available.

To select or to check matched pairs of components, no standard is necessary. The pairs are simply connected to the standard and unknown terminals, the difference between the components being indicated directly by the bridge.

### OTHER TYPICAL USES

Figure 5 shows the bridge being used to adjust an air core inductor used in the TYPE 1181-A Frequency Deviation Monitor to within 0.1 per cent of the standard coil. The start of the inductor winding is connected through a slip ring on the turntable to the bridge. The other end of the inductor winding is connected directly to the bridge. After the bridge is set to the desired value, turns are re-

moved from the coil until the cathode-ray indicator shows an exact balance.

One of the most time-saving applications of this bridge at General Radio Company is the testing for tracking of ganged potentiometers and capacitors. Figure 6 shows the four-gang condensers used in the TYPE 1302-A R-C Oscillator being checked before assembly. In a few seconds the condensers can either be adjusted to track correctly or rejected.

Other uses include checking transformer turns ratio or balance in center-tapped windings, and the measurement of capacitors as small as fractional micromicrofarads. Measurement of the changes in impedance of chemical solutions is also possible, permitting precise control of some chemical processes. The high accuracy and versatility of the TYPE 1604-B Comparison Bridge make it extremely useful for nearly all production and engineering jobs where the quantity to be measured can be reduced to a change in impedance.

— M. C. HOLTJE

### SPECIFICATIONS

**Deviation Range:** For impedance difference,  $\pm 5\%$  and  $\pm 20\%$ , selected by a panel switch. For dissipation factor difference,  $\pm .006$  at 400 c,  $\pm .015$  at 1 kc,  $\pm .075$  at 5 kc.

**Impedance Range and Accuracy:** Impedances between  $2\Omega$  and  $20\text{ M}\Omega$  can be compared. For the  $5\%$  deviation range, the basic accuracy is  $\pm 0.1\%$ , but at extreme values of impedance the error is somewhat greater. The range for resistors, capacitors, and inductors for which the  $\pm 0.1\%$  accuracy applies is given in the table:

Frequency	R	L	C
400 c	$2\Omega$ to $20\text{ M}\Omega$	2 mh to 1500 h	100 $\mu\text{f}$ to 50 $\mu\mu\text{f}$
1 kc	$2\Omega$ to $20\text{ M}\Omega$	1 mh to 250 h	30 $\mu\text{f}$ to 50 $\mu\mu\text{f}$
5 kc	$4\Omega$ to $2\text{ M}\Omega$	200 $\mu\text{h}$ to 10 h	2 $\mu\text{f}$ to 50 $\mu\mu\text{f}$

These ranges apply for comparison of components whose dissipation factor differences do not exceed .02. On the 20% deviation range, the accuracy is  $\pm 0.5\%$  over the same impedance ranges.

**Dissipation Factor Accuracy:** The accuracy of measurement of differences of dissipation factor is:

Frequency	Accuracy
400 c	$\pm(0.0002 + 2\%$ of the impedance difference)
1 kc	$\pm(0.0005 + 2\%$ of the impedance difference)
5 kc	$\pm(0.0025 + 2\%$ of the impedance difference)

**Frequency:** Frequencies of 400 c, 1 kc, and 5 kc are provided, selected by panel switch. The frequency is within  $\pm 3\%$  of the nominal value.

**Grounding:** Two ground positions are provided, one of which grounds the junction of the standard and unknown impedances. With this connection, the total impedances between the high terminals and ground are compared. In the other connection, the junction of the ratio arms

Figure 5. The Comparison Bridge used in adjusting an air-core inductor to 0.1% tolerance at General Radio's West Concord (Mass.) plant.







Figure 6. Another application in our own plant: testing and adjusting four-gang capacitors for proper tracking. The bridge is also used in the adjustment of ganged potentiometers.

values of impedance the voltage is decreased, corresponding to a source impedance of the order of 100 Ω.

**Zero Adjustment:** An adjustable index mark is provided with locking means so that the zero can be offset to correspond to the deviation of the standard component from the desired nominal value.

**Power Supply:** 105-125 (or 210-250) volts, 50 to 60 cycles.

**Accessories Supplied:** Line-Connector cord.

**Accessories Required:** Adjustable calibrated standards such as the TYPE 1432 Decade Resistors, TYPE 219 Decade Capacitors, and TYPE 1490 Decade Inductors may be used. Fixed standards such as the TYPE 509 Standard Capacitors, TYPE 1481 and TYPE 1482 Inductors, and TYPE 500 Resistors may also be used whenever appropriate values are available.

For production tests, the standard is often a component of the type to be tested, that has been measured independently or otherwise selected.

**Accessories Available:** TYPES 1231-P2 and 1231-P5 Filters for providing frequency discrimination.

**Mounting:** Welded aluminum cabinet.

**Dimensions:** (Width) 12 inches, (height) 14 1/4 inches, (depth) 10 inches, over-all.

**Net Weight:** 22 1/2 pounds.

of the bridge is grounded, leaving both terminals of the standard and unknown ungrounded. With this connection, the direct impedance between terminals of a component is measured, and terminal impedances to ground, within certain limits, will not affect the bridge balance.

**Voltage Applied to Unknown:** Approximately one volt, for impedances above 500 Ω. For lower

Type		Code Word	Price
1604-B	Comparison Bridge .....	FATTY	\$390.00

Licensed under patents of the Radio Corporation of America.

Delivery from stock, as with 9 out of 10 General Radio products

# GENERAL RADIO COMPANY

SINCE 1915—MANUFACTURERS OF ELECTRONIC APPARATUS FOR SCIENCE AND INDUSTRY

275 MASSACHUSETTS AVENUE  
CAMBRIDGE 39 MASSACHUSETTS  
TELEPHONE: TRowbridge 6-4400

## BRANCH ENGINEERING OFFICES

NEW YORK 6, NEW YORK  
90 WEST STREET  
TEL.—WOrth 2-5837

LOS ANGELES 38, CALIFORNIA  
1000 NORTH SEWARD STREET  
TEL.—HOLlywood 9-6201

CHICAGO 5, ILLINOIS  
920 SOUTH MICHIGAN AVENUE  
TEL.—WAbash 2-3820

## REPAIR SERVICES

WEST COAST  
WESTERN INSTRUMENT CO.  
826 NORTH VICTORY BOULEVARD  
BURBANK, CALIFORNIA  
TEL.—ROckwell 9-3013

CANADA  
BAYLINE ENGINEERING, LTD.  
FIRST STREET  
AJAX, ONTARIO  
TEL.—Toronto EMpire 8-6886