

OPERATING INSTRUCTIONS
FOR
TYPE 636-A
WAVE ANALYZER
FORM 351-D



GENERAL RADIO COMPANY
CAMBRIDGE A, MASSACHUSETTS





FIGURE 1. Type 636-A Wave Analyzer

BEFORE ATTEMPTING TO OPERATE THE
TYPE 636-A WAVE ANALYZER
READ THIS INSTRUCTION BOOK CARE-
FULLY; PART II AND PART III IN
PARTICULAR

CAUTION

DO NOT DISTURB ANY OF THE
CONTROLS INSIDE THE CABINET.
SEE PARAGRAPHS 3.12, 3.14,
3.21

SERVICE DEPARTMENT
GENERAL RADIO COMPANY
CAMBRIDGE MASSACHUSETTS



GENERAL RADIO COMPANY

OPERATING INSTRUCTIONS FOR TYPE 636-A WAVE ANALYZER

PART I PURPOSE

This wave analyzer is intended for the measurement of individual periodic components of a complex voltage wave, such components having amplitudes between 200 microvolts and 200 volts and having fre-

quencies between 20 cycles and 15,000 cycles. It is, essentially, a sensitive vacuum-tube voltmeter with an extremely sharp frequency characteristic.

PART II PRINCIPLE

2.1 The Type 636-A Wave Analyzer is of the heterodyne type. The incoming signal is mixed in a push-pull detector with a carrier signal whose frequency is controlled by the large dial on the front panel. When the carrier is so adjusted that the sum of its frequency and that of one of the components of the signal equals 50,000 cycles the resultant signal is passed through a highly selective two-section quartz-crystal filter and its amplitude measured on a meter.

2.2 The detector is so designed that the effective mutual conductance of the tube varies linearly with the grid voltage. It will be noticed from Figure 2 that the carrier signal is applied simultaneously to the two grids in the same phase. This means that (except for lack of balance between the tubes and between wiring capacities, both of which may be corrected for by the C and R balance adjustments) the carrier signal is completely balanced out of the amplifier. If a fixed d-c voltage is applied between the

two grids this balance is destroyed and the carrier reappears.

2.3 If a sinusoidal signal is applied from grid to grid, a half sinusoidal pulse of high frequency appears, from plate to plate of the detector, for every half cycle of the signal, resulting in a modulated wave having a scallop-shaped envelope. Quite clearly the amplitude of this envelope is proportional to the peak amplitude of the sinusoidal signal in just the same ratio as the unbalanced carrier output was proportional to the unbalancing d-c bias in the preceding example. It is easy to show that the detector output described above is built up of two side-bands differing from the carrier frequency by the frequency of the modulating signal, the carrier itself being suppressed. These two side-bands have peak intensities equal to one-half the peak envelope amplitude.

2.4 This may sound a little complicated, but the result is simple: the

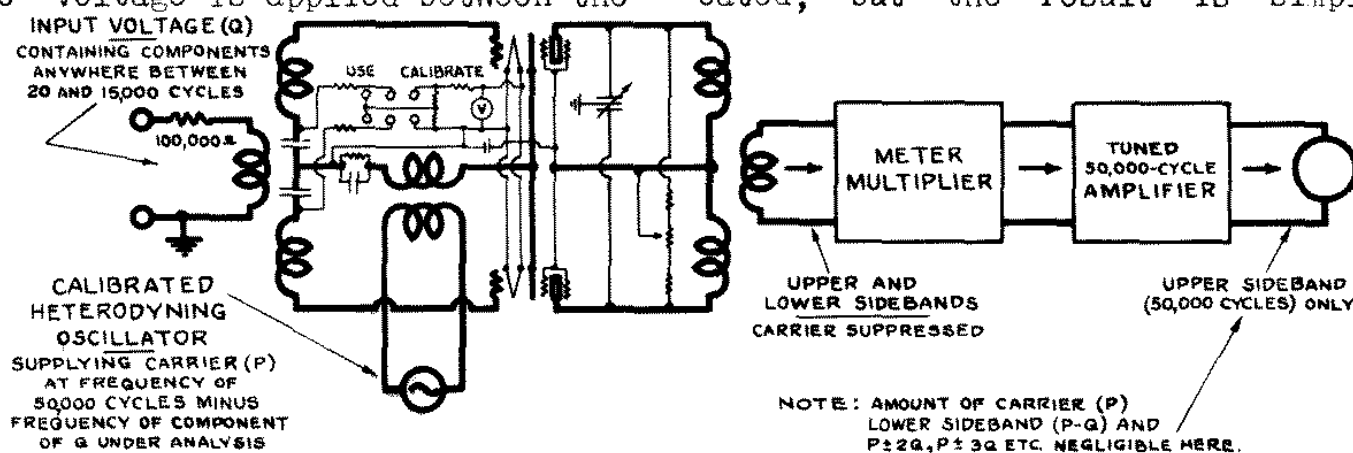

FIGURE 2. Functional diagram showing the operating principle of the wave analyzer

GENERAL RADIO COMPANY

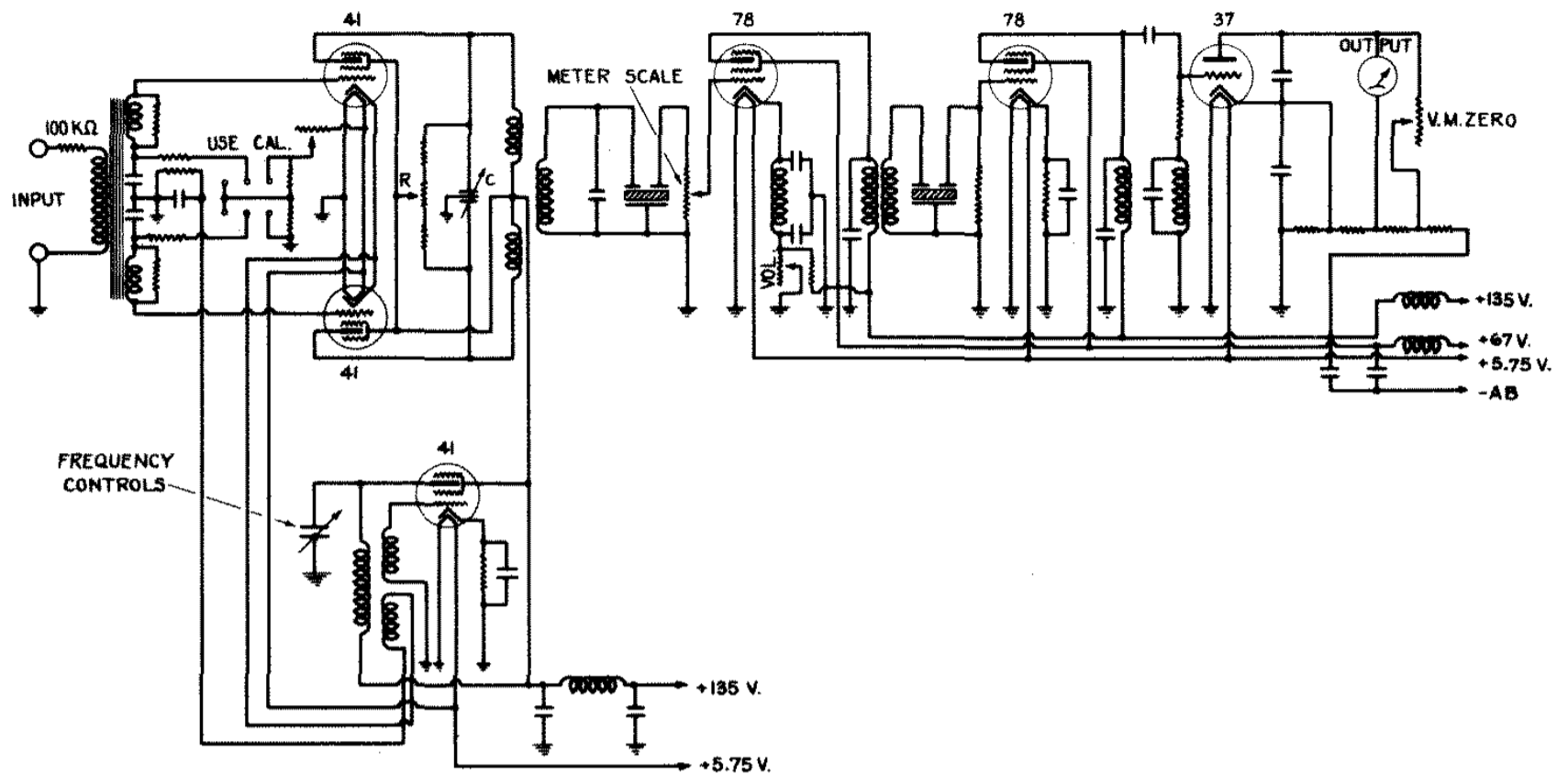

FIGURE 3. Schematic wiring diagram for Type 636-A Wave Analyzer

ratio of single side-band amplitude to signal amplitude is numerically one-half of the ratio of unbalanced carrier to unbalancing bias (for simplicity all voltages considered are peak rather than r-m-s). This suggests an obvious method of calibration. Let one volt (d-c) be applied from grid to grid. Let the amplifier gain be adjusted to give a unit deflection when tuned to the unbalanced carrier. It follows that a unit deflection when obtained from a sinusoidal input signal by tuning to the upper side-band, will signify a peak signal amplitude of 2 volts. It also follows that the calibration is entirely independent of detector tube characteristics.

2.5 In practice, this principle has been used with slight modification. At the factory a low-frequency signal of 2 volts

root-mean-square is applied and the amplifier gain is adjusted to give a full deflection on the meter when set on the 2-volt scale. A calibrating bias is then provided which will give the same reading due to the related carrier unbalance. This bias is obtained by a voltage divider placed across the filament voltmeter as indicated on the schematic, Figure 2.

2.6 The amplifier has been provided with a calibrated attenuator (labeled METER SCALE) which merely changes the gain by known amounts.

2.7 It will be noticed that the argument given above makes no mention of the values of detection coefficients or of amplifier gain. Both are taken into account automatically by the calibration.

GENERAL RADIO COMPANY

PART III DESCRIPTION OF PARTS

AMPLIFIER, ATTENUATOR,
AND CRYSTAL FILTERS

3.11 The amplifier assembly contains a 100,000-ohm attenuator marked METER SCALE MULTIVOLTS, two 50-kc crystals, two stages of amplification, and a tube voltmeter. It will be noticed from Figure 3 that the first of the two crystals is terminated by the attenuator which serves to damp it electrically. This is done primarily for the purpose of making the alignment between the two crystals less critical.

CAUTION

3.12 The crystals are mounted in the two sealed boxes, one of which is shown in Figure 4. Baffles are provided to minimize radiational damping. These have been carefully adjusted to give half-wavelength gaps and should not be moved. Each crystal is supported on the base by a narrow strip of felt and at the top by a small square of felt held in place by a set-screw. It is not anticipated that the crystals will ever get out of adjustment and neither the seals nor these setscrews should be touched unless the user has positive evidence that the crystals have fallen out of alignment and then only after communicating with the Service Department of the General Radio Company.

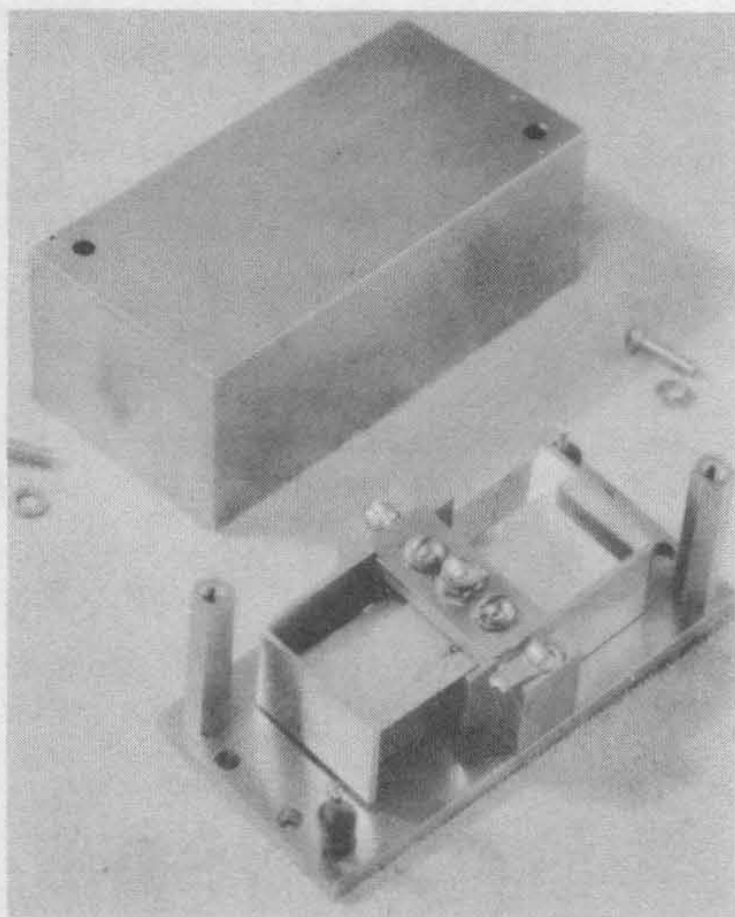

FIGURE 4. One of the 50-kc quartz bars

3.13 The volume control (VOL) of the amplifier consists of a 20,000-ohm rheostat which governs the grid bias of the first amplifier tube.

3.14 The amplifier itself is very carefully shielded to avoid regeneration in the high-impedance carrier-frequency circuits. This is particularly necessary around the grid circuit of the second tube since the resonant crystal impedance is of the order of 1/2 megohm. The tuned impedance coupling units are contained in the square aluminum cans.

CAUTION

The trimmer condensers have been carefully adjusted at the factory and should not be disturbed.

DETECTOR AND AUDIO-INPUT
CIRCUIT - EXTERNAL MULTIPLIER

3.21 The detector assembly contains the detector circuit itself and the audio-input transformer. On the lower half of this shelf there is a 200-ohm rheostat which has been provided for calibration purposes at the factory. It controls the unbalancing bias mentioned in 2.4 and 2.5.

CAUTION

Under no circumstances must the adjustment of this rheostat be changed. To do so will upset the entire calibration of the instrument. To reset it requires that the entire instrument be returned to the General Radio Company for recalibration.

3.22 The audio-input circuit includes a 100,000-ohm plug-type resistor mounted on clips near the input terminals.

3.23 The external multiplier is a 10-megohm metallized resistor shielded in such a manner as to minimize direct capacitance. Measurements at 50,000 cycles indicate that this direct capacitance is smaller than 0.1 μf which is entirely negligible at the 15,000-cycle upper limit of the instrument. This resistor has been checked at the factory within 5%, but it may age and for precision work should only be relied upon for comparative values unless it is recalibrated. Its multiplying factor is x100.

3.30 The oscillator has been arranged to give a constant amplitude over

GENERAL RADIO COMPANY

its frequency range. The tuning condenser is made up of five condensers in parallel, a Type 505 mica unit, a small trimmer condenser which is adjusted at the factory, the main tuning condenser which has 270° rotor plates cut to give a well distributed scale, a zero-adjustment condenser (FREQ) mounted under the calibration door, and a small single-plate condenser (FINE TUNING) for very fine adjustments. Adjustment of this condenser can shift the frequency by approximately ± 15 cycles. From this the importance of a frequency change caused by moving this knob away from the mark can be estimated.

3.40 The panel controls consist of the two condensers mentioned under 3.30 and the following:

DET ADJUSTMENT: R is a 20,000-ohm plate-to-plate potentiometer diluted

by 75,000-ohm series resistors. See 2.2 and 4.24 to 4.27.

DET ADJUSTMENT: C is a three-plate split condenser for balancing distributed wiring capacities. See 2.2 and 4.24 to 4.27.

FIL is a 0.5-ohm filament rheostat for adjusting the filament voltage to 5.75 volts.

CALIBRATION: USE-CAL is the switch for controlling the grid-to-grid unbalancing voltage. It should be left in USE position except during the operation of checking the calibration. See 2.5 and 4.23 to 4.29.

CALIBRATION: VOL see 3.13 and 4.23 to 4.28.

VM ZERO is a 20,000-ohm rheostat used for balancing out the voltmeter-plate current. See 4.22 and 4.32

METER SCALE MILLIVOLTS see 3.11 and also Figure 3.

PART IV OPERATION

TO PLACE IN OPERATION 4.1 Place instrument on back and remove front panel from cabinet. Place tubes in proper sockets as follows: the oscillator and detector brackets should have 41-type tubes, the large amplifier assembly should have two 78's, and a 37 should be placed in the left-hand socket, looking from the rear. Replace the unit in the cabinet, pulling the battery cable through the hole in the shelf. Connect the yellow lead to B-, the blue lead to 67.5 volts and the slate lead to +135 volts. Provision has been made for clamping three Eveready #872 batteries in the lower compartment. To clamp these in place, first remove the two side blocks, put the batteries in place, and replace the blocks. Connect to a 6-volt storage battery and adjust the rheostat to give 5.75 volts on the filament. This adjustment is important since the entire calibration depends linearly upon it.

SELF-CONTAINED CALIBRATION METHOD 4.21 This method of securing the voltage calibration is the one discussed in 2.2 to 2.5 and requires no external voltage standard. The description of this method is purposely given in great detail, and the first time the instrument is used particular pains should be taken to follow every direction carefully. Later on, after one is familiar with the procedure and understands the operating principle of the instrument, short cuts can be considered. See also 4.31 for an optional method.

4.22 First, the plate current of the vacuum-tube voltmeter should be balanced out by adjusting the VM ZERO knob, after the main tuning control has been set to some point well removed from zero.

4.23 Next, check the zero-frequency-calibration adjustment by turning METER SCALE to the 2000 millivolt position, the main dial to zero, FINE TUNING to the mark, VOL as far counterclockwise as it will go, and USE-CAL at USE. Adjust the FREQ knob for an approximately maximum deflection. This should be done slowly so as not to miss the very sharp response point, but no great effort need be made to secure the exact maximum. If the meter reads off scale, an adjustment of C and R will bring it back. If no response point is found, increase the gain by turning the VOL knob or METER SCALE or both.

4.24 The detector must now be balanced to eliminate carrier, see 2.2. With METER SCALE set at 2000 millivolts adjust the C and R knobs for an approximate balance as indicated by a minimum reading (less than 1/4 scale) on the voltmeter.

4.25 Shift the USE-CAL knob to CAL and adjust VOL for full-scale deflection of the meter. This step can be omitted, if desired, after experience has shown when it is helpful.

4.26 Shift USE-CAL back to USE and very carefully adjust the C and R knobs for a minimum deflection, turning back the

GENERAL RADIO COMPANY

METER SCALE knob as increased sensitivity is required. If this adjustment be made with sufficient care, a meter reading of less than 20 millivolts can be obtained and the maximum error due to residual unbalance will be less than 1%. If less care be taken, the error can become correspondingly larger though not necessarily so because, the balance being vectorial, questions of phase enter in. An attempt to reduce this error to below 1% is seldom justifiable, and in making extremely precise measurements by the substitution method (5.2) the balance is not required.

4.27 The C and R adjustments are inherently critical, but it is necessary to have them adjusted closely during calibration only. Should they become disturbed slightly after calibration, no harm will be done (except when very low frequency signals - 20 cycles or less - of small amplitude are being measured. In this case any residual unbalance tends to appear as an interfering signal, and the balance should be made as perfect as possible. See 5.52 for additional comment on interfering signals).

4.28 Set the METER SCALE in the 2000-millivolt or CAL position and the USE-CAL knob at CAL. Adjust VOL for an exactly full-scale deflection after rechecking the tuning by turning the FINE TUNING control for maximum deflection. See 3.30 for the effect of the latter on the frequency calibration.

4.29 Return the USE-CAL switch to USE, carefully close the door, and the wave analyzer is ready to operate.

OPTIONAL METHOD OF CALIBRATION 4.31 In place of this method, which is entirely self-contained in the instrument, it is obviously possible to calibrate by applying a signal of known amplitude and any convenient frequency and then adjusting the VOL control until the instrument reads correctly. Due to the smallness of the frequency error, this one check will hold over the range of the instrument.

4.32 Before calibrating by this method, the vacuum-tube-voltmeter plate current must be balanced out as described in 4.22. It is also a good idea to balance out the carrier as described in 4.26, although the precise adjustment for balance is not required unless signals of low amplitude and low frequency (less than 20 cycles) are under measurement (see 4.27).

PRECAUTION AGAINST DETECTOR OVERLOADING 4.41 In order to avoid overloading the detector, no signal having an amplitude of more than 2 volts (200 v when using the external multiplier) should be applied. In particular, measurements on the harmonics of a signal should not be attempted until the fundamental has been reduced to 2 volts by external means. If this is not done, spurious frequencies may be introduced by the detector; frequencies corresponding to third, fourth, and higher order products.

4.42 The detector has been arranged to give essentially pure second order modulation, i.e. the output contains the terms $P+Q$ and not the terms $P+2Q$ and $P+3Q$; P being the carrier frequency and Q the signal frequency. The term $P+2Q$ (which gives rise to a reading with the tuning dial set at $2Q$ even though no $2Q$ is present) is to some extent balanced out by the push-pull detector arrangement; if the detector were perfectly symmetrical, none would be present. The term $P+3Q$ is smaller in amplitude but is not balanced out.

4.43 These products ($P+2Q$ and $P+3Q$) are less than 1/30 of 1%, a suppression of 70 db with not more than a 2-volt signal applied to the INPUT terminals.

4.44 As noted in Section 6.24 the detector tubes are matched at the factory to prevent an excessively high unbalanced condition to $P+2Q$.

FREQUENCY CHARACTERISTIC 4.5 Figure 5 shows the frequency characteristic of the analyzer. The errors are nearly entirely due to the input transformer. When it is thought necessary, corrections may be made on the data by applying the factor indicated on the curve for the frequency considered.

MULTIPLIER 4.61 In case it is desired to measure a voltage between 2 and 200 volts, the 10-megohm multiplier provided with the instrument should be used. This multiplier, as shipped, is accurate to $\pm 5\%$ but due to the aging inherent in such high resistance resistors, the unit should not be used for absolute but only for relative voltage measurements unless its valve is checked frequently. See 3.23 for effectiveness of shielding.

4.62 Care should be taken to keep correspondence between the ground terminals of the analyzer, multiplier, and circuit under test.

GENERAL RADIO COMPANY

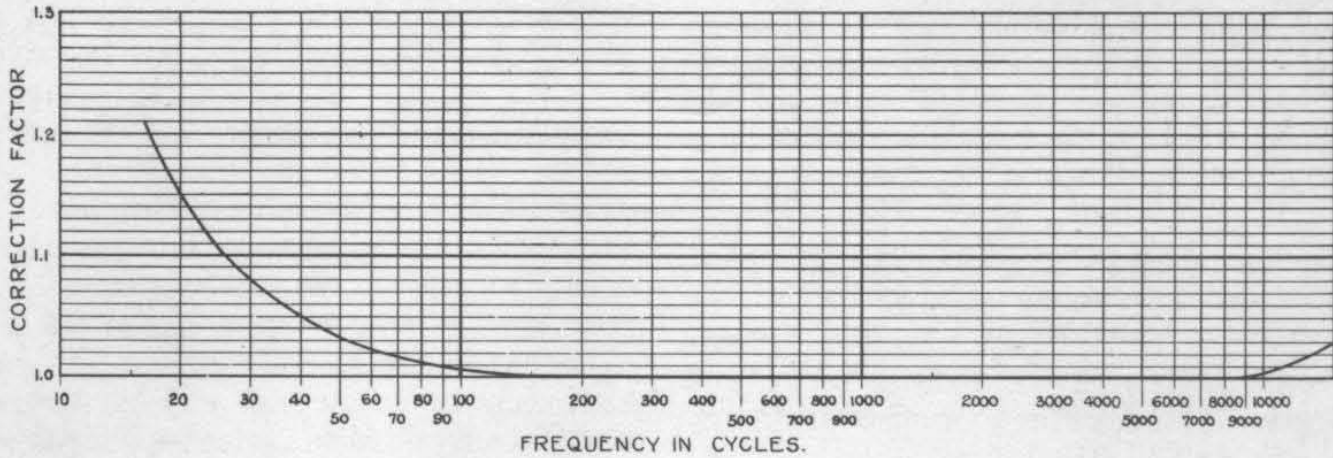

FIGURE 5. Frequency characteristic. See 4.5

PART V SUGGESTIONS AS TO USE

MEASUREMENT OF DISTORTION 5.1 In measuring harmonics, it is often desired to express these as percentages of the fundamental. One convenient way of doing this consists in adjusting the fundamental by external means to a deflection of 1000 millivolts (1 volt) after which the harmonic percentages are determined directly by taking one-tenth of the meter readings.

5.2 The accuracy of the instrument has been placed at 5% when used as a direct-reading voltmeter. In case much greater accuracy is needed for some particular case, external calibrating voltages may be applied in the same way that this is done with analyzers using the substitution method. This process is unwieldy, but in one case out of a hundred may be desirable.

USE AS VOLTMETER 5.3 Perhaps it is desirable to call attention to the fact that the analyzer can be used to measure the magnitude of voltages as well as their relative values. This may prove convenient in some cases.

5.4 The 10-megohm external multiplier should be an exceedingly useful tool in practical cases since it permits the analyzer to be connected to a circuit with little regard for that circuit's impedance and without bothering about d-c. For example, one might go down the stages of an amplifier grounding the low potential or

ground terminal to the negative plate-supply terminal of the amplifier and connecting the multiplier to successive grids and plates merely taking precautions to use as short a lead as necessary but disregarding the effect of grid biases and plate-supply voltages. This process permits a stage-by-stage study of gain, distortion, and power-supply noise.

SELECTIVITY 5.51 The selectivity curve is given in Figure 6. (This particular curve was computed from Q measurements on the two crystals as used in the experimental model. The curve has

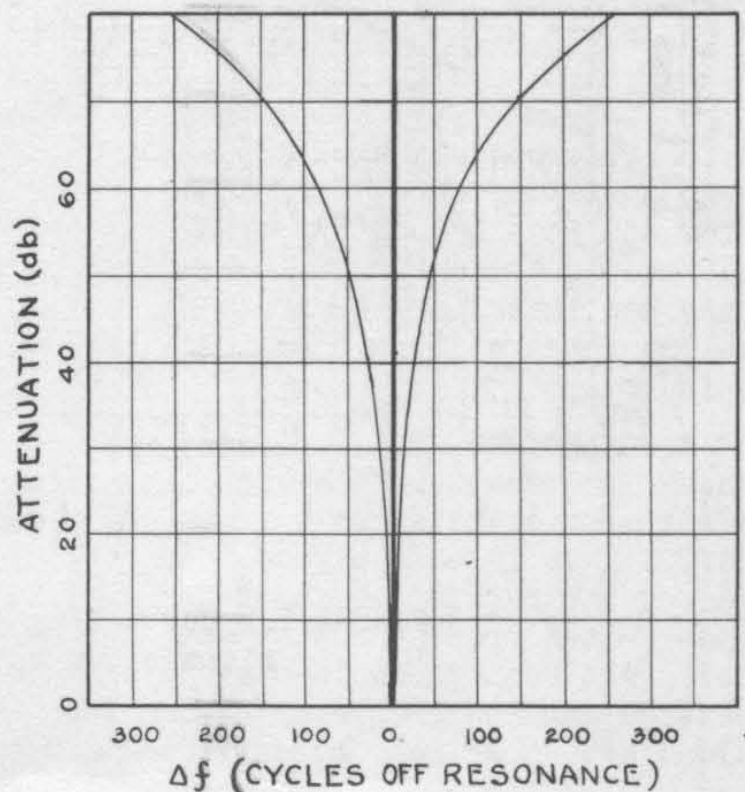

FIGURE 6. Over-all response characteristic of the quartz-crystal filter.

GENERAL RADIO COMPANY

been checked experimentally at a number of points on this first model and on several subsequent ones and found to be remarkably uniform. It will be noticed that a separation of 60 cycles corresponds to a discrimination of about 54 db or about 500 to 1. In some cases, this selectivity is not sufficient to permit the interfering frequency to be entirely neglected. In others, the deflection due to the interfering frequency may look unduly large and yet may have little effect on the accuracy.

5.52 Figure 7 has been included to show the magnitude of these errors and also to facilitate corrections if one desires to make them. Such corrections may be necessary in measuring very small power-frequency modulation and in similar extreme cases.

5.53 Assuming that the voltmeter reads r-m-s voltage, we can allow for the error due to interfering signals through the curve.

s = signal amplitude in volts.

b = voltage reading when tuned to signal.

a = voltage reading due to interfering signal when slightly detuned.

c = difference between these two readings. It is the voltage increment when the signal is tuned in.

To find signal amplitude, s ,

1. Measure $\frac{c}{b}$
2. Determine $\frac{s}{b}$ from Figure 7 and multiply by b .

CARRIER ENVELOPE ANALYSIS 5.6 The wave analyzer, in conjunction with a linear rectifier, can be used to measure the distortion in the envelope of a modulated radio-frequency wave. Those interested are referred to the General Radio Experimenter for February, 1936: Vol. X, No. 9.

FILTER MEASUREMENTS 5.7 On many types of electric-wave filters, accurate measurements are impossible unless a sharply-tuned voltmeter is used. This subject is discussed in the General Radio Experimenter for March, 1935: Vol. IX, No. 10.

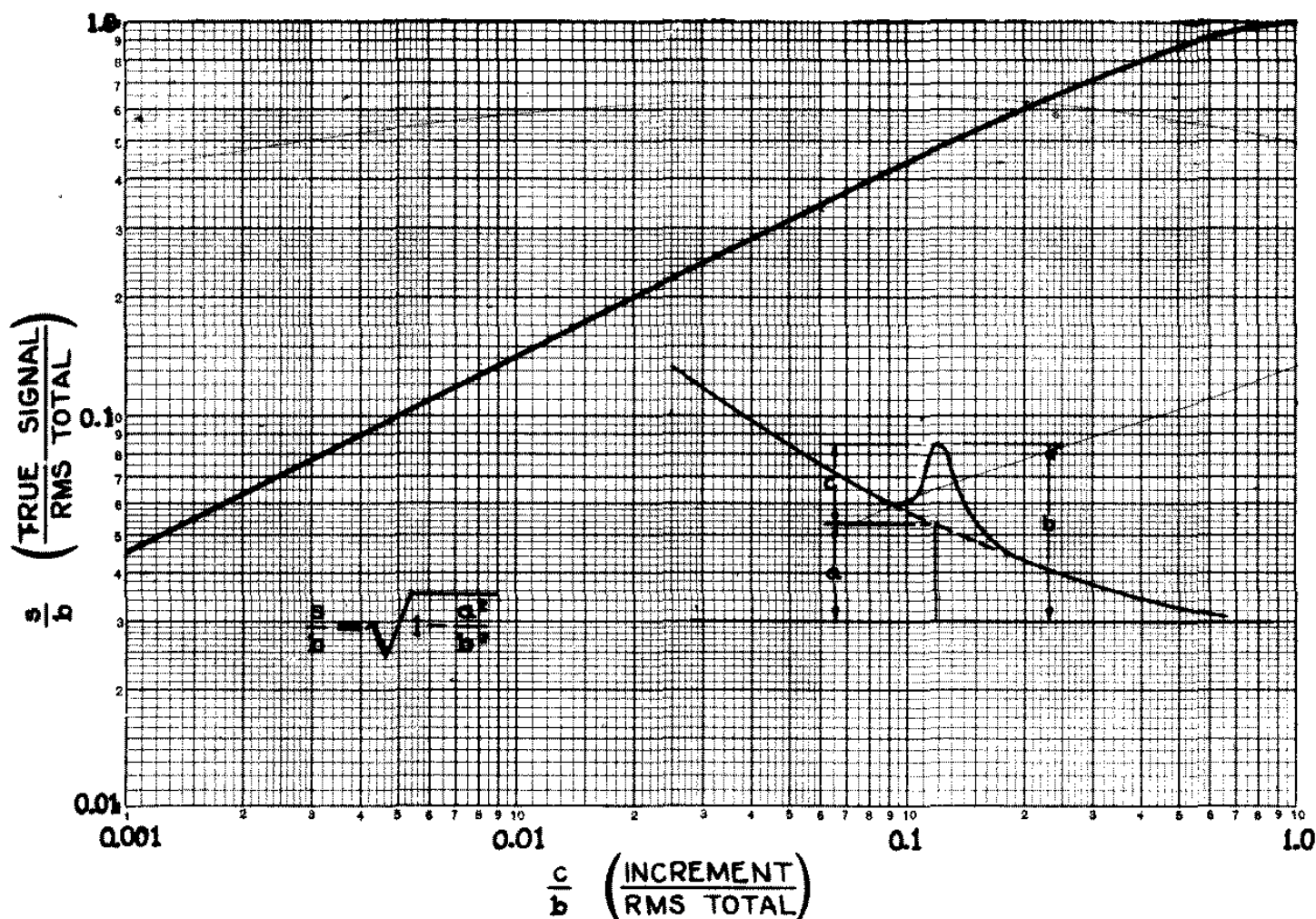

FIGURE 7. Curve from which effects of interfering signals can be computed. See 5.53

GENERAL RADIO COMPANY

PART VI SERVICING

BATTERIES 6.1 Plate batteries should be replaced when they drop below 110 volts. The filament battery meter is a dual-range instrument, pushing the button gives a measurement of plate-battery voltage.

TUBES 6.21 Tubes have been sent with the instrument for several reasons as noted below.

6.22 We do not anticipate any need of frequent replacement but are attaching these notes in case it ever becomes necessary. If the delay incurred by returning the instrument to the factory is not too serious, we can, of course, provide matched sets of tubes at a nominal service charge.

6.23 The Type 41 Oscillator Tube is not critical and has a negligible effect on the frequency calibration. A defective tube may be replaced at will.

6.24 The Type 41 Tube used as detectors have to be matched for two reasons; to suppress spurious third-order modulation as discussed in 4.42 and to make possible the complete suppression of the carrier frequency with the fairly small adjustment provided, i.e. C and R. Usually two tubes out of three will be found to match in this respect. Shifting from one socket to the other at times helps due to slight lack of symmetry in the detector output transformer. The balance as far as P-2Q is concerned can be determined by

impressing a carefully filtered sinusoidal input signal of 2 volts on the input and tuning to the second harmonic produced in the detector. It has been found that some 41-type tubes are markedly microphonic. Tapping a tube and listening to its mechanical tone is usually sufficient to test for this. A satisfactory tube will give a definite metallic ring; a poor tube will give evidence of loose elements.

6.25 The type 37 tube used as a voltmeter is not at all critical. As yet we have not found two tubes differing by more than 3% and usually the variation is much less than this.

6.26 The type 78 tubes are not critical and any two giving the proper gain can be substituted for those in the instrument.

LACK OF SENSITIVITY 6.3 Under abnormally humid conditions there may be a condensation of moisture on some of the parts, causing a lack of sensitivity which will make itself evident by failure to obtain full calibration scale reading by use of the volume control. In such a case the instrument will be satisfactory for relative measurements which are sufficient for most purposes. The defect will correct itself a few days after the return of normal weather or can be corrected artificially by drying the instrument by means of an incandescent lamp of about 25 watts placed within the cabinet.

PARTS LIST

RESISTORS

R-1 = 1 M Ω	R-11 = 5000 Ω
R-2 = 10 M Ω	R-12 = 5000 Ω
R-3 = 500 Ω	R-13 = 0.5 M Ω
R-4 = 0.1 M Ω	R-14 = 0.5 M Ω
R-5 = 20,000 Ω	R-15 = 75,000 Ω
R-6 = 3000 Ω	R-16 = 75,000 Ω
R-7 = 30,000 Ω	R-17 = 500 Ω
R-8 = 1000 Ω	R-18 = Type 301-404
R-9 = 10,000 Ω	A = 0.1 M Ω
R-10 = 20,000 Ω	

CONDENSERS

C-1 = 1.0 μ f	C-10 = 10-70 μ mf
C-2 = 1.0 μ f	C-11 = 0.1-0.1 μ f
C-3 = 0.0002 μ f	C-12 = 0.02 μ f
C-4 = 0.5 μ f	C-13 = 0.04 μ f
C-5 = 0.5 μ f	C-14 = 1.0 μ f
C-6 = 1.0 μ f	C-15 = 0.5 μ f
C-7 = 0.5 μ f	C-16 = 0.5 μ f
C-8 = 70-140 μ mf	C-17 = 300-650 μ mf
C-9 = 10-70 μ mf	

TUBES

T1 = Radiotron 41
T2 = Radiotron 41

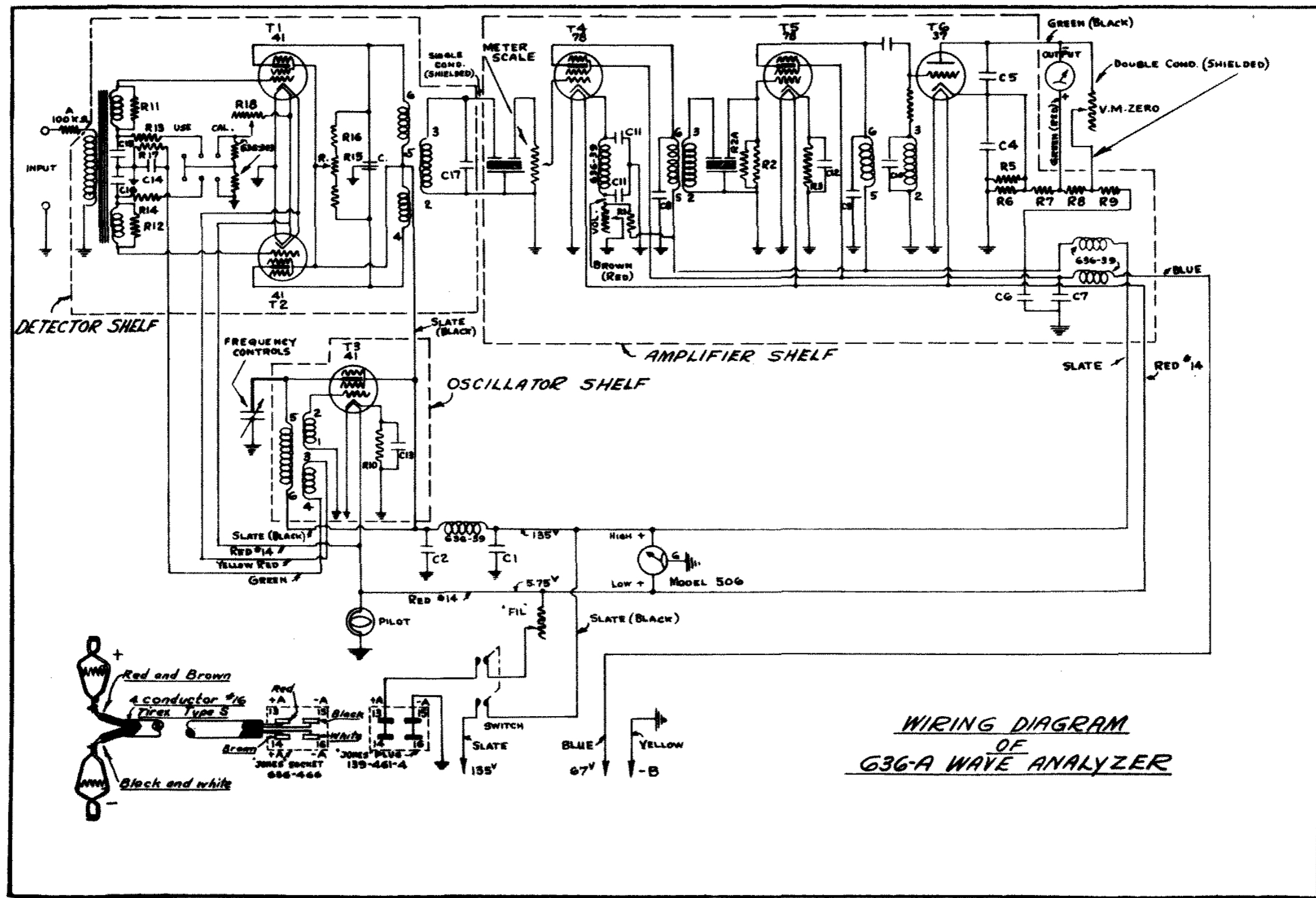

WIRING DIAGRAM
OF
636-A WAVE ANALYZER



PLANOGRAPH PRINTED BY SPAULDING-MOSS COMPANY
BOSTON, MASSACHUSETTS, U. S. A.



File Courtesy of GRWiki.org