

OPERATING INSTRUCTIONS

for

TYPE 1862-B MEGOHMMETER



G E N E R A L R A D I O C O M P A N Y

CAMBRIDGE 39, MASSACHUSETTS, USA



OPERATING INSTRUCTIONS

for

TYPE 1862-B MEGOHMMETER

Form 755-G
September, 1958

GENERAL RADIO COMPANY

275 MASSACHUSETTS AVENUE
CAMBRIDGE 39 MASSACHUSETTS

DISTRICT OFFICES

NEW YORK: Broad Avenue at Linden
Ridgefield, New Jersey

CHICAGO: 6605 West North Avenue
Oak Park, Illinois

PHILADELPHIA: 1150 York Road
Abington, Pennsylvania

WASHINGTON: 8055 13th Street
Silver Spring, Maryland

LOS ANGELES: 1000 North Seward Street
Los Angeles 38, California

SAN FRANCISCO: 1182 Los Altos Avenue
Los Altos, California

CANADA: 99 Floral Parkway
Toronto 15, Ontario

REPAIR SERVICES

WEST COAST
Western Instrument Company
826 North Victory Boulevard
Burbank, California

EAST COAST
General Radio Company
Service Department
22 Baker Avenue
West Concord, Massachusetts

MIDWEST
General Radio Company
Service Department
6605 West North Avenue
Oak Park, Illinois

CANADA
Bayly Engineering, Ltd.
First Street
Ajax, Ontario

Printed in U.S.A.



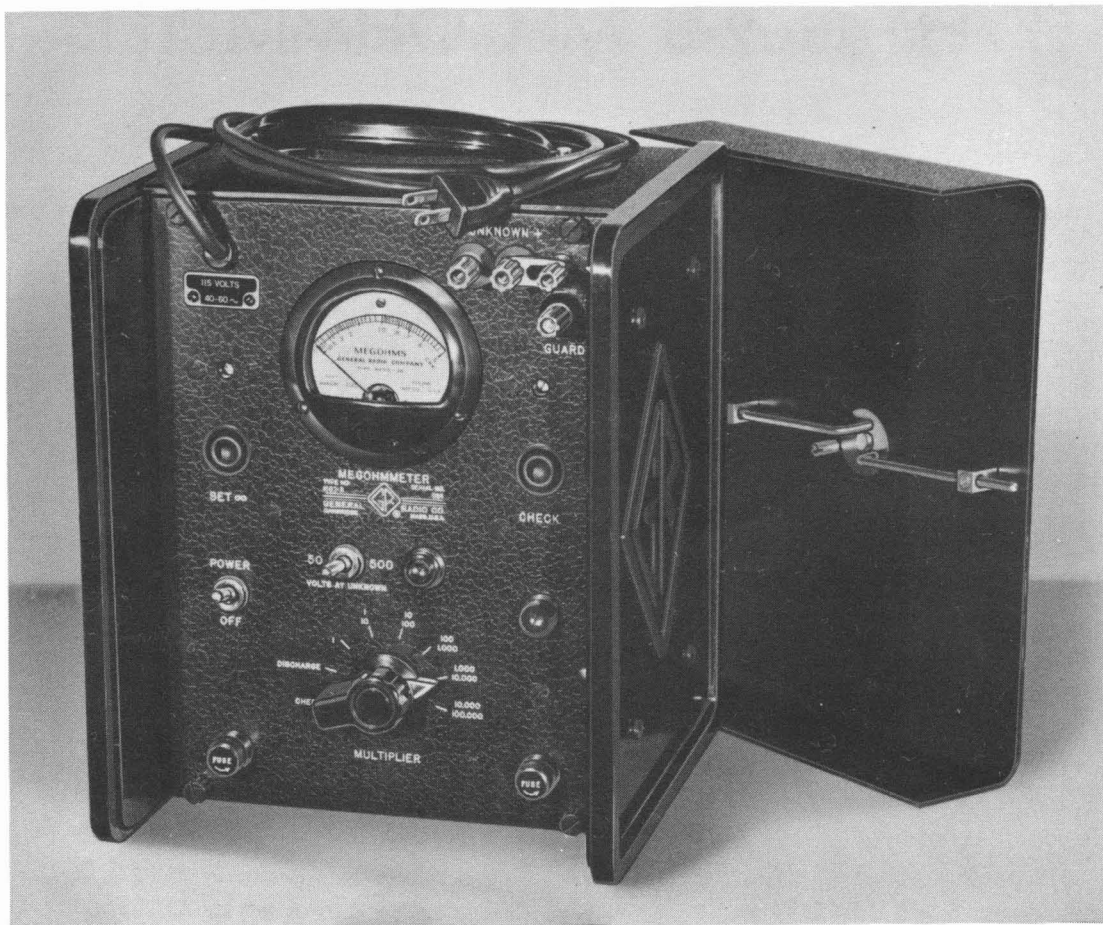

**Panel View of the Type 1862-B Megohmmeter
(For Specifications, see back of foldout.)**

OPERATING INSTRUCTIONS

for

TYPE 1862-B MEGOHMMETER

The Type 1862-B Megohmmeter is designed to indicate directly on the panel meter the resistance value of any resistor within the range of 0.5 to 2,000,000 megohms. The voltage applied to the unknown resistance is 500 volts within 10 volts, or 50 volts within 4 volts.

SECTION 1.0 OPERATING CONTROLS AND PROCEDURE

1.1 CAUTION - DANGER

When the instrument is on, there is a potential of 500 volts at the terminals except when the **MULTIPLIER** switch is set to **CHECK** or **DISCHARGE** or when the panel switch is at 50 volts.

1.2 POWER SUPPLY

The instrument is supplied complete, with tubes installed, and is ready for operation.

The power-line voltage and frequency are indicated on the panel label near the power input cable. The voltage is either 115 volts or 230 volts. To change from one input voltage to the other, see Paragraph 2.1 below.

1.3 VOLTAGE AT UNKNOWN

The voltage applied to the unknown is either 50 volts or 500 volts as selected by means of a panel switch. A neon lamp warns when 500-volt operation has been selected.

1.4 CONNECTIONS OF UNKNOWN

Strap the ground terminal to the **GUARD** terminal or to the adjacent **UNKNOWN** terminal.

With the **MULTIPLIER** switch at **DISCHARGE**, the meter should read ∞ (full counter-clockwise position of the meter pointer). If it does not, adjust the

GENERAL RADIO COMPANY

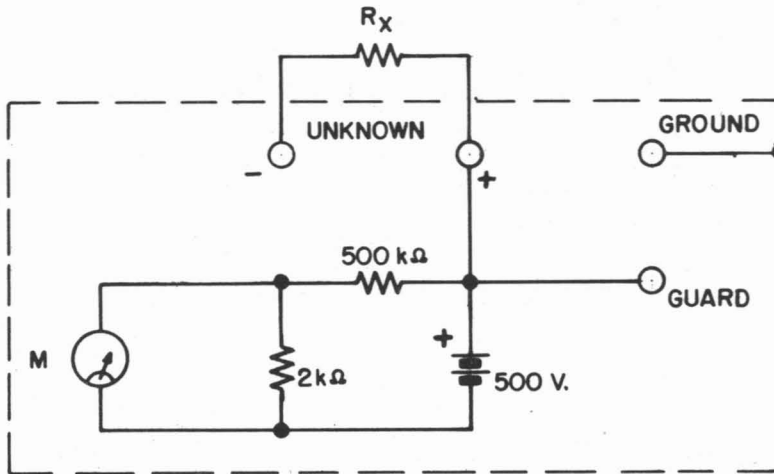

Figure 1. "Check" position of multiplier, with voltage switch at 500 volts.

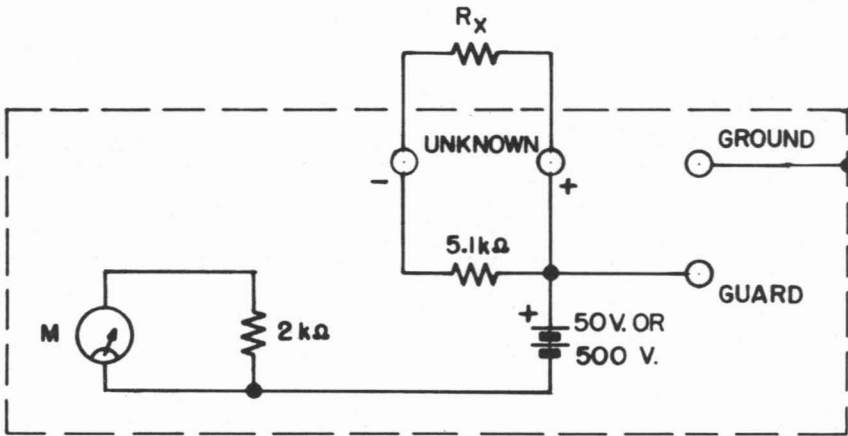

Figure 2. "Discharge" position of multiplier.

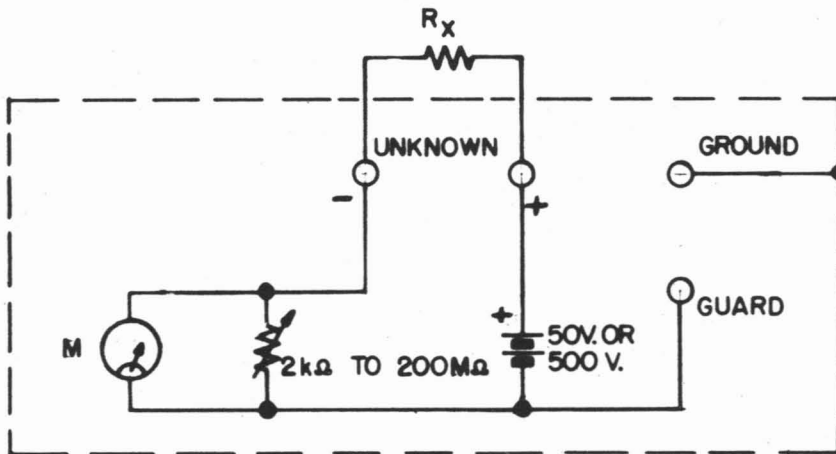

Figure 3. Operating position of multiplier.

TYPE 1862-B MEGOHMMETER

SET ∞ control to obtain an ∞ reading of the meter. As the MULTIPLIER switch is turned to the operating positions, the meter should continue to read ∞ . If it does not, see paragraph 2.3 below.

For a discussion of the CHECK position and of the GUARD and ground terminals, see Section 2.0 below.

The instrument is designed for operation with the panel in a horizontal position.

1.5 RESISTANCE INDICATION

With the MULTIPLIER switch at DISCHARGE, connect the unknown resistance to the UNKNOWN terminals. Move the MULTIPLIER switch to the "1" position. If the meter indicates beyond full scale (0.5), the resistance is less than 0.5 megohm and cannot be measured with this instrument. Return the MULTIPLIER switch to the DISCHARGE position immediately. If the meter indicates on scale, select the MULTIPLIER position that yields a meter reading between 0.5 and 5.

The resistance value is the product of the meter reading and of the MULTIPLIER setting. Read the MULTIPLIER positions indicated in white numerals when the operating voltage selected is 50 volts; read the positions indicated in red numerals when 500 volts has been selected.

CAUTION: Return the MULTIPLIER to the DISCHARGE position before attempting to disconnect the resistor from the UNKNOWN terminals.

SECTION 2.0 SECONDARY CONTROLS AND PROCEDURE

2.1 POWER SUPPLY

The power-line frequency range is 40 to 60 cycles. The voltage is either 115 volts or 230 volts. If it is desired to change from one input voltage to another, change the power transformer connections as shown on the wiring diagram, reverse the power-line label (near the power input cable) to indicate the proper line voltage and change the fuses (on the panel) to the proper rating (0.4 ampere Slo-Blo 3AG fuses for 115-volt operation and 0.2 ampere Slo-Blo 3AG fuses for 230-volt operation). For access to the power transformer connections, remove the instrument from its cabinet.

2.2 TERMINALS

In addition to the insulated terminals to which the UNKNOWN resistance is connected, there is an insulated terminal labeled GUARD and an uninsulated ground terminal which is connected to the panel and which includes a strap for grounding either the GUARD terminal or the adjacent (positive) UNKNOWN terminal. In the operating positions of the MULTIPLIER switch, there is a poten-

GENERAL RADIO COMPANY

tial of 500 volts (or 50 volts) between the GUARD terminal and the positive UNKNOWN terminal. Therefore, do not ever connect these two terminals together.

For most applications, strap the ground terminal to the adjacent UNKNOWN terminal. The polarity at this terminal is positive and is so indicated.

If the unknown resistor is a three-terminal type, it can be measured by connecting the third terminal to GUARD and by grounding the GUARD terminal or the positive UNKNOWN terminal, as shown in Figure 4 and Figure 5, provided that the resistances of the second and third resistors in the network are sufficiently large. R_B is connected directly across the internal standard, R_S , and must be at least one hundred times as large as R_S . At 500-volt operation, R_S is 2 k Ω times the MULTIPLIER setting (red numerals). At 50-volt operation, it is 20 k Ω times the MULTIPLIER setting (white numerals). R_C is connected directly across the internal power supply and must be at least one megohm for 500-volt operation and at least ten megohms for 50-volt operation.

CAUTION: Do not maintain a short-circuit at the UNKNOWN terminals. While a momentary short-circuit will do no damage, a prolonged short-circuit at the two lower ranges can draw excessive current from the high-voltage power supply and will shorten the life of the rectifier and regulator tubes (V-4 and V-5). At the higher multiplier ranges (100, 1000, 10,000 and 100,000), for 500-volt operation, the short-circuit current is 2500, 250, 25, and 2.5 μ a, respectively, and will do no harm. At all ranges, the panel meter current at short-circuit condition is about 500 μ a. The normal full-scale rating is 200 μ a.

2.3 CHECK AND DISCHARGE POSITIONS

With the MULTIPLIER switch in either of these positions, there is no voltage at any of the terminals; in the DISCHARGE position, the UNKNOWN terminals are shunted with a 2-watt, 5.1 k Ω resistor (R-2).

With the switch at DISCHARGE, the meter should indicate ∞ . If it does not, adjust the SET ∞ control.

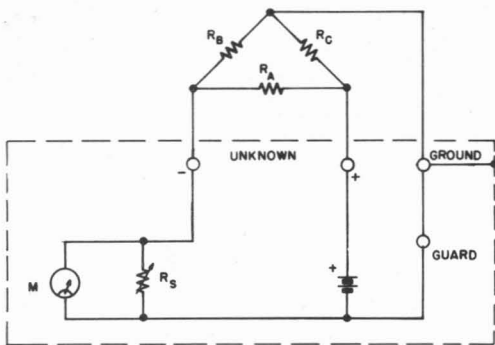

Figure 4. Connections for measuring ungrounded three-terminal resistor.

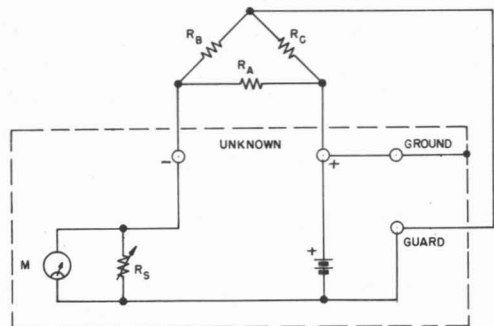

Figure 5. Connections for measuring grounded three-terminal resistor.

TYPE 1862-B MEGOHMMETER

As the MULTIPLIER switch is rotated through the operating positions, the meter will continue to indicate ∞ if nothing is connected to the UNKNOWN terminals. If there is a meter indication at the next-highest setting, this can be caused by leakage or by grid current in the voltmeter tube (V-1). Leakage due to moisture or dirt can be eliminated by wiping the UNKNOWN terminals with a clean dry cloth. Grid-current effects can occur when V-1 has been replaced with a new tube or when the instrument has not been used for some time. The grid-current effect will be eliminated or reduced to a negligible value (a meter reading that is less than halfway between ∞ and 20 is considered negligible) by leaving the instrument on for a short while. (See 3.0 under Service and Maintenance Notes.) If there is no meter indication at the lower multiplier settings, but an indication appears at the highest setting, reset to ∞ by adjusting the screw-driver control accessible through a small panel hole just above the SET ∞ knob.

When the MULTIPLIER is set to the CHECK position and the voltage switch is at 500 volts, an internal resistance standard is connected in circuit. The meter should read 0.5. If it does not, readjust the CHECK control knob.

2.4 FIVE-HUNDRED-VOLT SUPPLY

In the 500-volt operating position, there is a potential of 500 volts between the positive UNKNOWN terminal and the GUARD terminal. If, because of tube changes or any other reason, this voltage, as measured by a voltmeter of at least 1 M Ω resistance, is found to be incorrect, it can be adjusted by setting the screw-driver control accessible through a small panel hole just above the CHECK control knob. If this screw-driver control is reset, the megohmmeter calibration must be standardized by again setting the MULTIPLIER to CHECK and obtaining a 0.5 (or CHK) reading on the meter, readjusting the CHECK control knob if need be.

2.5 FIFTY-VOLT SUPPLY

After the 500-volt supply has been standardized as described above, the 50-volt supply can be checked and adjusted if necessary. For the 50-volt operating position, there must be a potential of 51 volts between the positive UNKNOWN terminal and the GUARD terminal when measured with a meter of 10 megohms or more resistance (49.7 volts with a one-megohm meter). If the voltage is not correct, it can be adjusted by resetting, with a screw-driver, the voltage divider mounted inside the instrument on the left-hand side of the shelf (R-35).

2.6 RESISTANCE OF CAPACITORS

The leakage resistance of capacitors is measured in exactly the same manner as the resistance of resistors except that the charge- and discharge-currents involved require some precaution.

2.61 Always short-circuit the capacitor for several seconds before connecting to the megohmmeter, to assure that it has no dangerous residual charge.

GENERAL RADIO COMPANY

2.62 Always start the **MULTIPLIER** at the **DISCHARGE** position.

2.63 Always set the **MULTIPLIER** at the "1" position for a few seconds to assure rapid charge of the capacitor. To prevent damage to the meter, do not set the **MULTIPLIER** to higher values until the capacitor is well charged.

2.64 When the measurement has been completed, discharge the capacitor by setting the **MULTIPLIER** to **DISCHARGE** for several seconds before disconnecting the capacitor. In the **DISCHARGE** position, the capacitor is discharged by the 5.1-k Ω , 2-watt resistor (R-2) which appears in shunt at the **UNKNOWN** terminals.

2.7 CHARGING TIME

Since the panel meter reading of the megohmmeter depends on the current through the unknown resistor, the leakage resistance of a capacitor or of an insulator cannot be correctly indicated until the charging current due to the capacitive component is negligible.

When the capacitor has very little dielectric absorption, the charging current is limited mainly by the resistance standard in the megohmmeter. In the lowest multiplier position, this resistance is 2000 ohms and for even large capacitance values the charging time is relatively small, being of the order of one second per hundred microfarads.

Many capacitors and most insulators (especially those of laminated structure) exhibit appreciable dielectric absorption (dipole and interfacial polarization). When a voltage is applied, the charge slowly diffuses throughout the volume and it may require minutes or hours (even days in some special cases) before equilibrium is established and the charging current is small compared to the true leakage current.

2.8 INSULATION TESTING

In testing the insulation of electrical machinery, transformers, etc., while the leakage resistance is important, it is only one of several parameters that have a bearing on the condition of the insulation. Routine measurements of capacitance and dissipation factor as well as leakage resistance provide useful data in monitoring the condition of the insulator and in guarding against incipient breakdown.

A routine test that has been fairly widely adopted in the insulation-testing field consists of measuring the apparent leakage resistance after a testing voltage of 500 volts has been applied for one minute and again for ten minutes. The ratio of the indicated resistances, sometimes referred to as the polarization index, can have some relation to the condition of the insulator. The results of course are really a measure of the charging current at the two time intervals and can be much more dependent on the dielectric absorption of the insulator

TYPE 1862-B MEGOHMMETER

than on its true leakage resistance. To extend the usefulness of such information, complete charge-current vs. time data should be obtained.¹

The Type 1862-B Megohmmeter is useful in measuring the true leakage resistance by the method outlined in Paragraph 2.6 above and in measuring the apparent leakage at the end of one-minute and ten-minute intervals.

The resistance in series with the insulator during the charging period is determined by the setting of the MULTIPLIER control; it is the product of the red MULTIPLIER reading and 2000 ohms when the applied voltage is 500 volts.

The charge current is easily measured when the meter is on scale; the charge current is the applied voltage divided by the apparent resistance at any moment; the meter will be off scale at the start of the charge-current vs. time characteristic.

2.9 TEST LEADS AND ACCESSORIES

Two rubber-covered test leads, one red and one black, are supplied. Each is 36 inches long and has a banana plug at one end and an alligator clip at the other. Although these test leads are adequate over most of the resistance range, measurements of very high resistance may require shorter leads or even shielded leads, depending on the physical size of the component under test and on the ambient field conditions.

CAUTION

When using the test leads, remember that there can be 500 volts between them.

3.0 SHOCK HAZARD

Every precaution has been taken in the design of the Type 1862-B Megohmmeter to reduce the possibility of shock. However, the operator should be aware of the dangers involved because of the high voltages present. The resistance to current depends, of course, on humidity conditions. From arm to arm, leg to arm, leg to leg, it can be as low as 300 ohms but under some circumstances it can be as high as one megohm. At low voltages, the skin offers a fair protection but at higher voltages, the skin is burned, its resistance is lowered and the low internal body resistance is controlling.

¹ "The Basis for the Nondestructive Testing of Insulation," R.F. Field, AIEE Transactions, September, 1941. "Interpretation of Current-Time Curves as Applied to Insulation Testing," R.F. Field, Boston District Meeting AIEE, April 19-20, 1944.

GENERAL RADIO COMPANY

When the MULTIPLIER switch of the Type 1862-B Megohmmeter is in an operating position, touching the two UNKNOWN terminals with one finger is painful and can cause a slight burn. The amount of direct current that will flow, at 500-volt operation, for various values of "body" resistance connected from the GUARD terminal to the positive UNKNOWN terminal is shown plotted in Figure 6. Currents due to connection to the UNKNOWN terminals will always be less; the value depends on the setting of the MULTIPLIER switch. See CAUTION under Paragraph 2.2. Since the lethal value depends on the individual and on humidity conditions, extreme caution must be observed at all times.

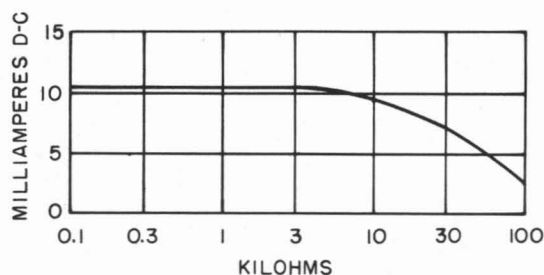

Figure 6. Current due to a load from GUARD to positive UNKNOWN terminals for 500-volt operation.

When a large capacitor is connected to the UNKNOWN terminals, it should be treated with great caution because there can be 500 volts at its terminals and it may have no appreciable inherent current-limiting series resistance. The current that will flow through the body upon connecting the "body resistance" to its terminals will at first be very great and the speed with which the current is damped depends on the capacitance as well as the resistance. A current-limiting resistor of one megohm should be connected as near to the capacitor as possible. Current decay curves for various values of capacitance and of "body resistance" are shown in Figure 7.

3.1 VOLTAGE COEFFICIENT OF RESISTORS

The resistance of some small resistors and of many insulators is affected by the voltage applied. A voltage coefficient of -0.05 percent per volt is not unusual. At 500 volts, if the coefficient is -0.05 percent, the resistance will be lower than its "zero volts" value by 25 percent. If the unknown is measured at 500 volts and then at 50 volts, the voltage coefficient of resistance can be calculated.

3.2 RESISTANCE AT OTHER VOLTAGES ACROSS UNKNOWN

If an adjustable power supply (such as the General Radio Type 1204-B Unit Variable Power Supply) and an accurate d-c voltmeter are available, they can be used with the Type 1862-B Megohmmeter to measure resistance with any value less than 500 volts applied to the unknown.

The procedure is as follows: Remove V-4 and V-5 (2X2-A and 6AB4) to disconnect the internal 500-volt supply. Set the voltage selector switch to 500

TYPE 1862-B MEGOHMMETER

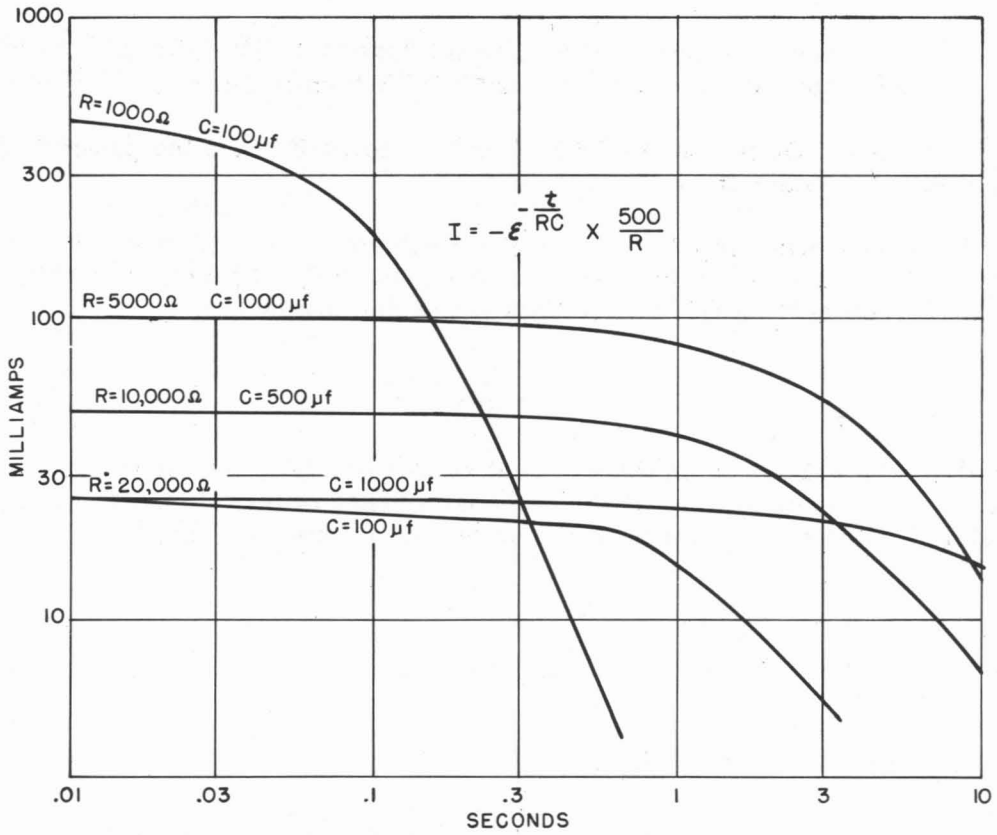

Figure 7. Discharge currents for 500 volts at charge.

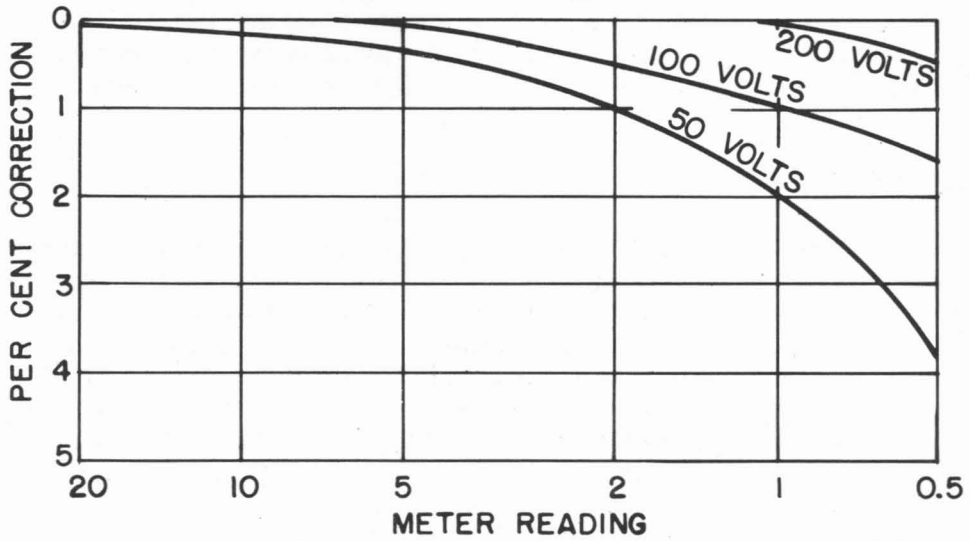

Figure 8. Correction when using external supply. See text.

GENERAL RADIO COMPANY

volts. Connect the external supply (with the external voltmeter across it) to the GUARD (minus) and the positive UNKNOWN terminals.

CAUTION: Do not set to CHECK or DISCHARGE since the power supply will be shorted under these conditions.

Set the external supply to the desired voltage. The resistance of the unknown is then measured in the normal manner using the 500-volt MULTIPLIER readings (red engraving). The resistance of the unknown is

$$R_x = \frac{E}{500} M$$

where E is the voltage from the external supply and M is the resistance indicated by the megohmmeter. If the external voltage is less than 100 volts, the calculated resistance must be reduced by the amount indicated in Figure 8.

SERVICE AND MAINTENANCE NOTES

1.0 INSTRUMENT IN CABINET

- 1.1 At 115-volt (or 230-volt) line, the power input is about 25 watts.
- 1.2 Fuses and pilot light are accessible from the panel.

2.0 INSTRUMENT OUT OF CABINET

- 2.1 All tubes and components are accessible.
- 2.2 Note that the shaft of the selector switch (S-1) and the switch-mounting screws can be 500 volts above ground. The switch is mounted on a black phenolic plate and the control-knob (MULTIPLIER) set-screw holes are plugged with wax.

3.0 GRID CURRENT

To test for grid current (see 2.3 of Operating Instructions) at 500-volt operation, set to the "1" multiplier and obtain an " ∞ " meter reading, then set to the "10,000" multiplier and obtain a meter reading that is less than halfway between ∞ and 20. A meter reading greater than this indicates excessive grid current or leakage. Leakage is eliminated by cleaning the terminals. Grid current may be excessive if the instrument has not been used for some time; normal operation for ten minutes will reduce the grid current satisfactorily. Grid current may also be excessive if the tube (V-1) has been replaced.

If the tube has been replaced and grid current is excessive even after several minutes of operation, age the tube by leaving the power on for several hours (at least eight). When the indicated grid current is satisfactorily low for the 10,000 multiplier, set to the 100,000 multiplier and obtain an ∞ meter

TYPE 1862-B MEGOHMMETER

reading by adjusting the screw-driver control accessible through a small panel hole just above the SET ∞ knob.

4.0 METER FLUCTUATIONS

If the line voltage is erratic or fluctuates seriously, the meter reading will also fluctuate when measuring the leakage of capacitors unless the 500-volt supply is very well stabilized. The potentiometer, R-33, has been set for almost perfect stabilization. If, however, V-6 or V-7 or particularly V-4 have been replaced, it may be necessary to readjust R-33. This is important only for capacitance leakage measurements. The procedure is simple. A Variac[®] or other means is used to vary the line voltage and R-33 (mounted on the shelf, under the meter) is adjusted for negligible meter variation when the UNKNOWN is a capacitor, (e.g., a mica 10,000 $\mu\mu\text{f}$ with resistance indication on the highest multiplier range).

5.0 VACUUM-TUBE DATA

The following table gives tube-socket voltages measured from socket pin to ground. The data were obtained with the instrument operating under the following conditions: 115-volts, 60-cycle line, ground terminal strapped to GUARD terminal, MULTIPLIER switch at "1", voltage switch at 500, CHECK control full counter-clockwise, SET ∞ control at about the middle of its range.

The d-c voltages were measured with a 20,000-ohm-per-volt instrument whose full-scale ranges were 10 volts, 50 volts, 250 volts, and 1000 volts. D-C voltages can be expected to vary $\pm 20\%$. Tabulated voltages are dc.

Symbol	Type	Socket Pin Number										Function
		1	2	3	4	5	6	7	8	9	Cap	
V-1	12AU7	+55	0	+3	---	---	+55	0	+3	---	---	V-T Voltmeter
V-2	0A2	+55	-90	---	-90	+55	---	-90	---	---	---	B Supply Regulator
V-3	6X4	-90	---	---	---	0	-90	+125	---	---	---	B Supply Rectifier
V-4	2X2-A	+900	+500	---	+900	---	---	---	---	---	+820	500-v Supply Rectifier
V-5	6AB4	+900	+75	---	---	+500	+490	+500	---	---	---	Series Regulator
V-6	6AU6	+85	+88	---	---	+470	+220	+88	---	---	---	Regulator Amplifier
V-7	5651	+88	0	---	0	+88	---	0	---			Reference Voltage

Parts List for Type 1862-B Megohmmeter

RESISTORS

R-1 =	10 Megohms	±10%
R-2 =	5.1 k Ohms	± 5%
R-3 =	4.3 k Ohms	± 5%
R-4 =	3.3 k Ohms	±10%
R-5 =	100 k Ohms	± 5%
R-6 =	100 k Ohms	± 5%
R-7 =	140 k Ohms	±10%
R-8 =	495 k Ohms	±1/2%
R-9 =	2 k Ohms	±1/2%
R-10 =	20 k Ohms	± 1%
R-11 =	200 k Ohms	± 1%
R-12 =	2 Megohms	± 1%
R-13 =	20 Megohms	± 1%
R-14 =	100 Megohms	± 1%
R-15 =	100 Megohms	± 1%
R-16 =	1 Megohm	±10%
R-17 =	15 k Ohms	± 5%
R-18 =	62 k Ohms	± 5%
R-19 =	22 k Ohms	±10%
R-20 =	22 k Ohms	±10%
R-21 =	500 Ohms	±10%
R-22 =	330 Ohms	±10%
R-23 =	5.1 k Ohms	± 5%
R-24 =	560 k Ohms	± 5%
R-25 =	20 k Ohms	±10%
R-26 =	24 k Ohms	± 5%
R-27 =	1 Megohm	±10%
R-28 =	270 k Ohms	± 5%
R-29 =	22 k Ohms	±10%
R-30 =	100 k Ohms	±10%
R-31 =	100 k Ohms	±10%
R-32 =	15 Ohms	±10%
R-33 =	100 k Ohms	±10%

*Part of P-1 Socket

TYPE

REC-30BF
 REW-6C
 REW-4C
 POSW-3
 REC-20BF
 REC-20BF
 POSC-11
 REPR-17
 REPR-17
 REF-1-2
 REF-1-2
 REF-1
 REF-80
 REF-80
 REF-80
 REC-20BF
 REC-20BF
 REC-20BF
 REC-20BF
 REC-20BF
 POSW-3
 REC-20BF
 REW-6C
 REC-30BF
 POSC-11
 REC-20BF
 REC-20BF
 REC-41BF
 REC-20BF
 REC-20BF
 REC-20BF
 REW-3C *
 POSC-11

R-34 =	20 k Ohms	±10%
R-35 =	25 k Ohms	±10%
R-36 =	47 k Ohms	± 5%
R-37 =	620 Ohms	± 5%
R-38 =	2.2 Megohms	±10%
R-39 =	820 Ohms	± 5%

CONDENSERS

C-1 =	.005 μf	±10%	COM-35B
C-2			
C-3			
C-4			
C-5 =	20 μf	450WV	} COEB-20
C-6 =	20 μf	450WV	
C-7			
C-8			
C-9 =	.15 μf	±10%	COL-57
C-10			
C-11 =	.25 μf	±10%	COL-26
C-12 =	16 μf	150 WV	COE-4

MISCELLANEOUS

S-1 =	Switch	4P8T	SWRW-63
S-2 =	Switch	DPST	SWT-333
S-3 =	Switch	DPDT	SWT-335
M-1 =	Meter	200 μa	MEDS-50
F-1, F-2 =	0.4 amp for 115V Slo-Blo 3AG	GR	FUF-1
F-1, F-2 =	0.2 amp for 230V Slo-Blo 3AG	GR	FUF-1
P-1 =	Pilot Light		2LAP-939
PL-1 =	Plug	Part of	CAP-1-2
T-1 =	Transformer		485-468-2



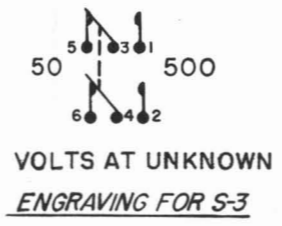
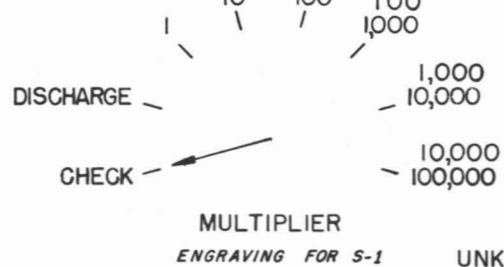
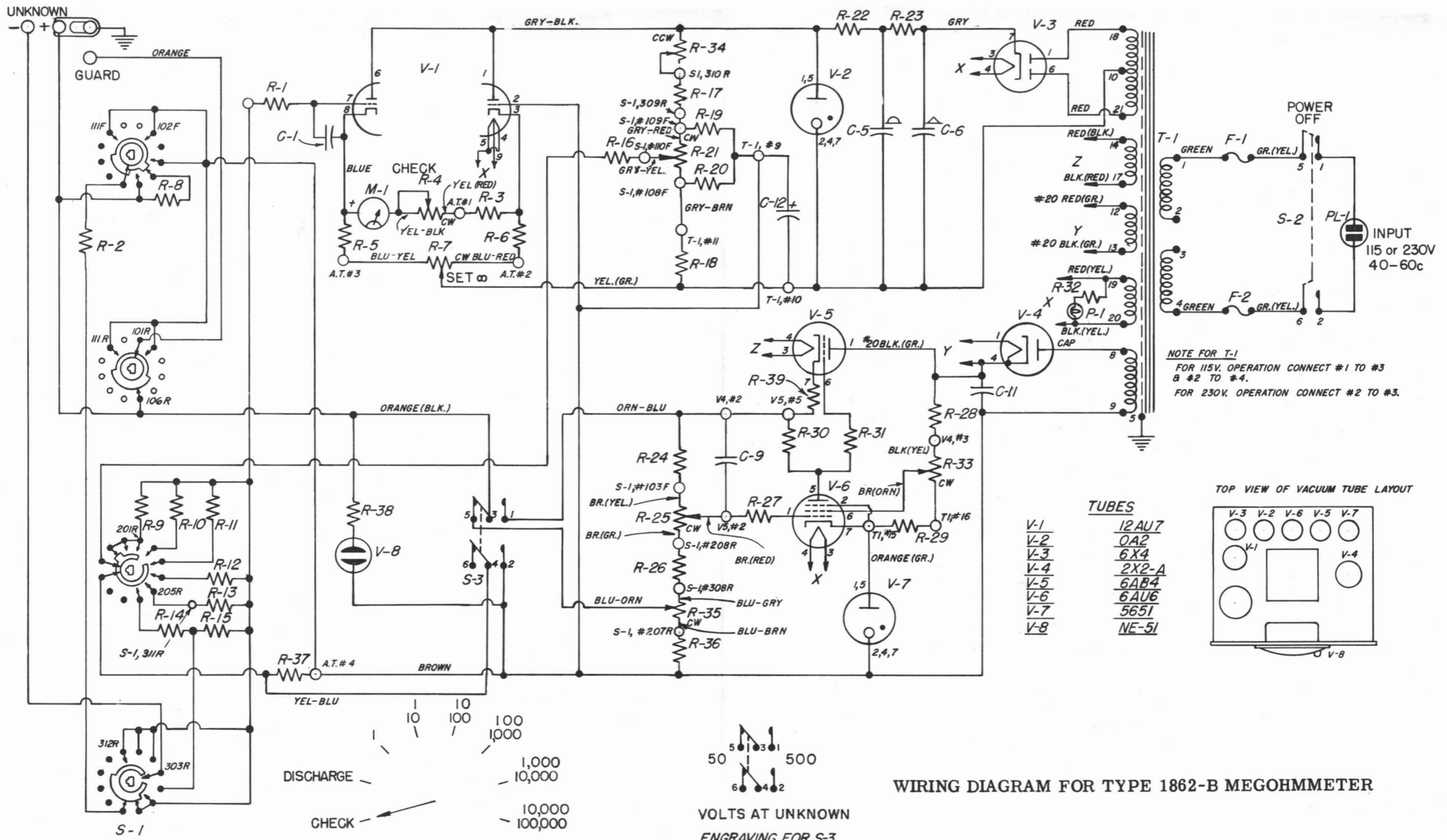

WIRING DIAGRAM FOR TYPE 1862-B MEGOHMMETER

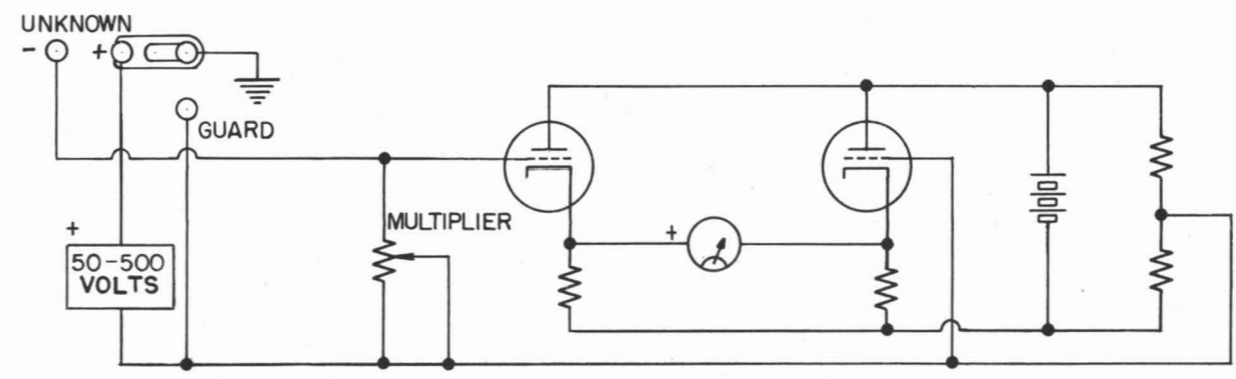

ELEMENTARY SCHEMATIC WIRING DIAGRAM

SPECIFICATIONS

Voltage at Unknown: The voltage applied to the unknown is 500 volts or 50 volts as selected by means of a panel switch. A neon lamp warns when the 500-volt supply has been selected. Over a 105-125-volt range in line voltage and over the resistance range of the instrument, the variation in voltage across the unknown resistor will be less than ± 10 volts at 500 volts and less than ± 4 volts at 50 volts.

Range: 0.5 megohm to 2,000,000 megohms at 500 volts and to 200,000 megohms at 50 volts. There are six decade steps as selected by a multiplier switch.

Scale: Each resistance decade up to 500,000 megohms (50,000 megohms for 50 volts) utilizes 90% of the meter scale. Center scale values are 1, 10, 100, 1000, and 10,000 megohms with, in addition, a center scale value of 100,000 megohms for 500-volt operation.

Accuracy: For 500-volt operation, the accuracy in percent of indicated value at all but the highest multiplier setting is $\pm 3\%$ at the low-resistance end of each decade, $\pm 8\%$ at mid-scale and $\pm 12\%$ at the high-resistance end. There can be an additional $\pm 2\%$ error at the highest multiplier setting. For 50-volt operation, there is an additional $\pm 2\%$ error on all but the 0.5-5 megohms decade where the additional error can be $\pm 5\%$.

Terminals: In addition to terminals for connecting the unknown, ground and guard terminals are provided. At two positions of the panel switch, all voltage is removed from all terminals to permit connection of the unknown in safety. In one of the positions, the UNKNOWN terminals are shunted to discharge the capacitive component of the unknown. All but the ground terminal are insulated.

Check: A switch position is provided for standardizing the calibration at 500 volts.

Design: Since field applications are more severe than laboratory use, the instrument was designed to be unusually rugged. The carrying case can be completely closed; accessory power cable and test leads are carried in the case. Controls are simplified for use by untrained personnel.

Tubes: Supplied with the instrument: one 12AU7, one OA2, one 6X4, one 2X2-A, one 6AB4, one 6AU6, one 5651 and one NE-51.

Controls: A switch for selecting the operating voltage, a switch for selecting the multiplying factor, a control for standardizing the calibration, a control for setting the meter to the infinity reading and a power switch.

Mounting: The instrument is assembled on an aluminum panel finished in black crackle lacquer and is mounted in an aluminum cabinet with black-wrinkle finish and with black-phenolic protective sides. The aluminum-cover finish is black wrinkle. The case is provided with a carrying handle.

Power Supply: 115 (or 230) volts at 40 to 60 cycles. The power input is about 25 watts.

Accessories Supplied: Two 3-foot color-coded test leads.

Dimensions: (Height) 10-1/8 inches x (width) 9-1/8 inches x (depth) 11-3/4 inches overall.

Weight: 15-1/4 pounds.



