

PULSES IN A SMALL PACKAGE— A PULSE GENERATOR FOR THE UNIT LINE

Also
IN THIS ISSUE

Page

THE VARIAC® AS AN ADJUSTABLE-RATIO CURRENT TRANSFORMER . 8

● THE TYPE 1217-A UNIT PULSER makes available for the first time a self-contained, universal pulse generator in a small, economical package. Previously available pulse generators have been limited in usefulness by restricted ranges of adjustment for both pulse duration and repetition rate. These limitations have

been overcome in the new Unit Pulser, which is a truly general-purpose instrument.

The Unit Pulser, designed as an addition to the versatile Unit-Instrument¹ line, provides, for the first time, continuously adjustable pulse durations from 0.2 μ sec to 60,000 μ sec, making possible generation of "flat tops" extending over a half cycle of frequencies as low as 10 cycles. A self-contained oscillator drives the output at pulse-repetition rates of 30 and 60 cycles for low-frequency tests and, in a 1-2-5 sequence, from 100 cycles to 100 kc for other tests.

¹"New Unit Instruments," *General Radio Experimenter*, Vol. XXVI, No. 2, July, 1951, p. 1.

Figure 1. Panel view of the Type 1217-A Unit Pulser with the Type 1203-A Unit Power Supply.

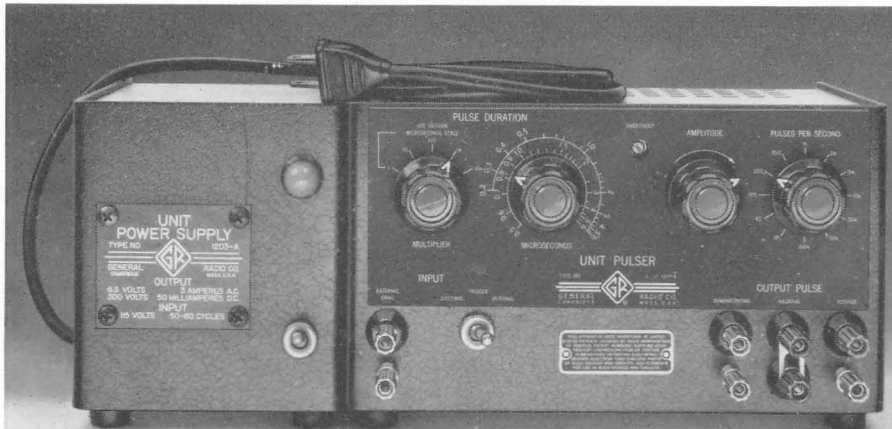

GENERAL DESIGN CONSIDERATIONS

The "pulser" or the "pulse generator" is the energy source for systems which operate in the time domain (or in which time-domain techniques are the analytical tools). As such a source, the pulser is a unique device, because, unlike d-c or sinusoidal-waveform-producing devices, the idealized pulse source gives rise to an infinite number of frequencies. Just how large a segment of the resulting infinite frequency band must be produced depends upon the particular application for which the pulser is intended.

An ideal pulse source would produce three distinct types of driving waveforms. These are: (1) The unit impulse, a pulse of infinite voltage amplitude and infinitesimal duration produced

once only. (2) The step function, a voltage transition of unit amplitude occurring once only. (3) Repetitive pulses of uniform amplitude, duration, and period of repetition, in which all three of these variables are arbitrarily adjustable.

In the Unit Pulser these three types of driving function are approximated as closely as the gain-bandwidth capabilities of currently available vacuum tubes will permit. The pulses of shortest duration (around 0.2 microsecond) at low repetition rates are an adequate approximation of the unit impulse for many applications. The 60,000-microsecond maximum value for pulse duration, when initiated by a single external trigger, makes a reasonable approximation of the step function. The pulse duration can be adjusted continuously between these two extremes over the entire range from 0.2 to 60,000 microseconds. The internal timing oscillator produces twelve basic repetition rates from 30 c to 100 kc, and a provision for external triggering permits continuous frequency variation from 100 kc to any arbitrarily low frequency.

The independently adjustable variables — repetition rate, pulse duration, and amplitude — make design compromises necessary in any pulse generator. For example, with the TYPE 1217-A Unit Pulser, one can always produce a pulse duration of a half-period or more at any frequency above 8 cycles. Although square waves are useful for testing amplifier systems, their generation places stringent demands on the output circuits if high-powered pulses (say, 1 amp. into 50 ohms) are desired. Since the choice of the ratio of pulse-time to period is unrestricted, the TYPE 1217-A

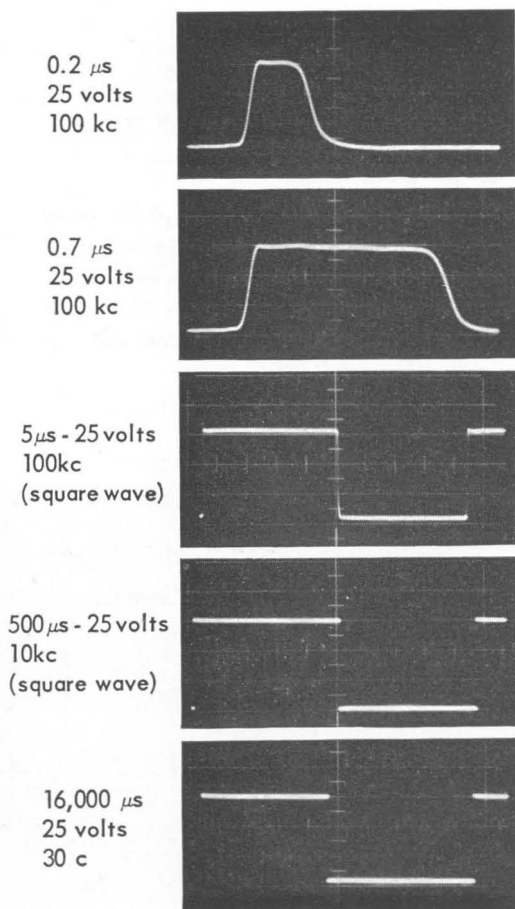

Figure 2. Oscillograms of typical pulse waveforms delivered by the Unit Pulser.



is designed to limit the output voltage without appreciable pulse-shape deterioration when the load demands too much power. The open-circuit output is about 25 volts behind 200 ohms. With a 50-ohm load, this output voltage drops to approximately two volts.

CIRCUITS

Figure 3 is a functional block diagram of the Unit Pulser. The circuits are: a blocking oscillator, which can also be driven as a trigger circuit; a monostable multivibrator, which controls the duration of the pulse; an amplitude control and limiter system; and a simple output stage capable of delivering either or both positive and negative pulses.

The oscillator that sets the repetition frequency (number of pulses per second) is an RC-timed blocking oscillator.² When the period for the pulses is to be determined by an externally generated signal (sine wave or pulse), the blocking oscillator tube is biased beyond cutoff. This form of oscillator is used, first, because it provides a lot of energy in a brief pulse, which increases the rate of rise of the leading edge of the pulse; and, second, because it is easily synchronized either at its fundamental period or at multiples and sub-multiples of this period. The oscillator frequency is

switched in twelve steps, in a 1-2-5 series, from 100 cps. to 100 kc. The two lowest frequencies are locked to the power line; they are 30 and 60 cps. for standard U. S. power systems. An adjustment is provided to permit the oscillator to be locked to 25 and 50 cps. for 50-cycle power systems.

When the repetition frequency is to be determined by an external source, the blocking oscillator is disabled by adding a fixed bias voltage and is used as a trigger circuit to feed the pulse-forming system. Since the oscillator is completely inoperative in the absence of an external trigger pulse, trigger pulses can be used to produce periods as long as the user desires. The upper frequency limit with external triggers depends upon the type of trigger waveform, its amplitude, and the repetition-rate switch setting. For frequencies lying below 10 kc, five-volt sine waves are adequate for continuous locking; as the upper limit of 100 kc is approached, the amplitude of the locking voltage must be increased to about 25 volts.

The monostable multivibrator is of the conventional grid-coupled type.³ A potentiometer adjusts a reference voltage for continuous control of pulse duration over a 12:1 range. An RC network is selected by the decade range

²Benjamin, R., "Blocking Oscillators," *Journal of the I. E. E.*, pt. III-A, 1947, p. 1170.

³Chance, B., et al., *Waveforms*, Radiation Laboratory Series, Vol. 19, p. 166.

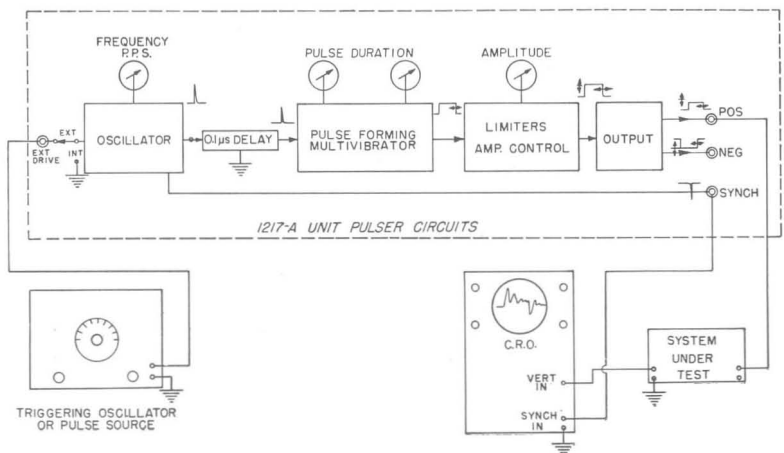

Figure 3. Block diagram of the Unit Pulser showing the functional arrangement of internal circuits and connections to external equipment.

switch to provide time-constant multipliers covering durations from 0.5 to 60,000 μ sec in five steps.

The analysis set forth on page 178 of reference (3) shows that the pulse duration is expressed by

$$T_{\text{pulse}} = RC \log_e \frac{E + e_{p_1}}{E + e_{c_1}} \quad (1)$$

Where E is the adjustable reference voltage controlled by the time duration knob, e_{p_1} is the plate swing of the second tube, and e_{c_1} the cutoff voltage of the first tube.

Thus the pulse duration varies logarithmically with the reference voltage. A "logarithmic" potentiometer is so connected that its variation of resistance with angle tends to compensate for the resulting non-linearity and yield a desirable scale distribution.

Some energy obtained directly from the blocking oscillator during the brief period of its conduction is added to that produced during transition of the monostable multivibrator to produce a steep wavefront. Even though the monostable stage is aided by the oscillator, it still must have all of the bandwidth possible to produce the steep wavefront desired, so two pentode tubes, a 6AK5 and 6AH6, are used.

The limiter and amplitude-control circuit consists of two germanium-diode limiters, which set the maximum and minimum voltage limits of the pulse and clip the extremes of voltage correspond-

ing to the "top" or "bottom" of the pulse. The lower diode voltage is fixed. The amplitude-control potentiometer provides d-c grid voltage for a cathode-follower circuit, which applies an adjustable voltage at a low impedance to the upper-limit diode. The pulse "top" is clipped by the conduction of the diode between 1 and 25 volts above the level set by the lower diode. The amplitude-control voltage, corresponding to the "top" of the pulse, is regulated with respect to ground to make the amplitude of the pulse essentially independent of pulse duration, repetition rate, and line voltage transients.

The output circuit comprises both sections of a 12AT7. This tube is connected in such a way that it can be used as (1) a cathode follower for the positive pulse, (2) as a phase splitter to produce equal-amplitude positive and negative pulses, or (3) as an amplifier to produce a negative pulse of about 60 volts amplitude at an impedance level of about 1200 ohms. The necessary wiring changes are made by moving a shorting bar at the output terminals.

At this point it should be noted that the connections from the monostable multivibrator through the limiter-amplitude control are all d-c coupled; so that, even with a 50-ohm load resistor on the positive-output terminals, pulses of the longest durations maintain the flat tops desirable in checking low-frequency response. Since the negative pulse is pro-

Figure 4. Elementary schematic circuit diagram of the Unit Pulser.

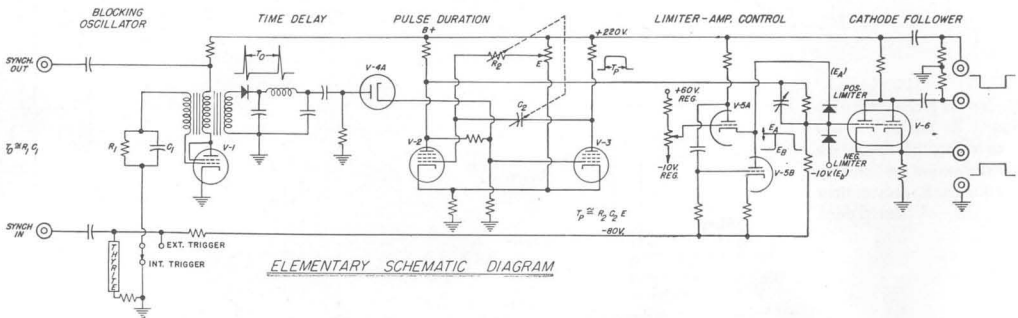



duced at the plate of the output stage, a blocking capacitor must be used, and load impedances of the order of 5 megohms are necessary to preserve pulse shape at the longest durations.

With the limiter form of amplitude-control circuit chosen for this design, there is some tendency for a small amount of high-frequency energy to be coupled around the limiter into the output circuit. These noise components only become noticeable when the amplitude control is set near its minimum value, so an accessory voltage divider is supplied with the instrument to reduce the maximum amplitude to 2.5 volts and to reduce the noise proportionately. The output impedance of this attenuator is approximately 200 ohms.

APPLICATIONS

Once the specifications for the Unit Pulser have been listed, it seems almost redundant to point out specific applications to the interested reader. It has been shown in the first portion of this article that the TYPE 1217-A Unit Pulser is capable of approximating all three basic pulse-source waveforms: impulse, step function, and periodically repeated pulse of adjustable duration. Whether or not the approximation these

waveforms provide is acceptable depends upon the particular application. Since the Unit Pulser produces pulses with rise and fall times requiring video bandwidths equivalent to those obtained in all but the most expensive oscilloscopes currently available, it is satisfactory for most applications requiring an oscilloscope as an indicator.

In applications in which the pulser is inserted in a system to produce a synchronizing or gating pulse, it is often necessary to move the time position of this pulse relative to the time reference set by a master trigger. This operation requires the insertion of a time delay between the master trigger and the initiation of the synchronizing or gating pulse. Figure 5 shows how a TYPE 1217-A Unit Pulser can be used, with a simply constructed differentiating circuit, to provide a delayed trigger pulse after a time interval equal to its arbitrarily set pulse duration. The external triggering circuit of a second Unit Pulser will accept this pulse to initiate a final output pulse, so the combination of two instruments will provide a very flexible "phasing" unit and source of delayed pulses. The time diagram accompanying Figure 5 shows the over-all time relationships between the master trig-

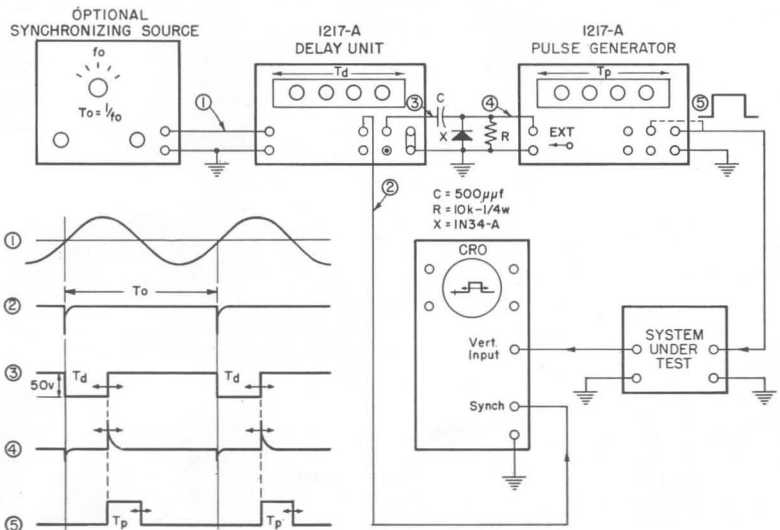

Figure 5. Block diagram of a system using two Unit Pulsers to provide pulses with adjustable time delay.

ger, delayed trigger, and final output pulses.

A Unit Pulser alone, or with another pulser as a delay generator, offers the engineer, scientist, and teacher a simple and inexpensive energy source for many pulse systems. A few of these uses follow:

1. Audio Systems: A single pulse generator can be used to generate a square wave from 10 c to 100 kc. The pulse can be used to operate an external gate to switch a sine wave to provide tone bursts. Square-wave outputs up to three watts can be obtained using a TYPE 1206-B Unit Amplifier following the Unit Pulser.

2. Computing Systems: As a substitution (block diagram) element to provide a gate over an adjustable period of time or a time-delay unit.

3. Nuclear Systems: The 1217-A can be used as a gate or time-delay generator. Two Unit Pulsers with an additional unit used as a delay stage can be used to check resolution times for low- or moderate-speed, coincidence systems.

4. Television Systems: A single Unit Pulser can be locked at the horizontal synchronizing frequency to check overall transient response of the video system, using the kinescope as an indicator. The 30- and 60-cycle internal lock, with the possibility of using a second unit for a delay circuit, makes possible the injection of a timed pulse anywhere during the period of a field or frame.

5. Pulse-Communication or Telemetering Systems: The Unit Pulser can be used as a "substitution block" in design, for producing a time-delay or monostable gate stage for example. With a stable source of synchronizing frequency, a clean and stable synchronizing pulse of adjustable phase can be formed.

6. Transient Analysis — Electro-Mechanical Analogues, etc.: The TYPE 1217-A Unit Pulser with an oscilloscope can be used for numerous experiments on linear, passive, networks. Since pulses are available over a wide frequency range, almost any sort of oscilloscope

Figure 6. The Unit Pulser used for production tests on amplifier assemblies.





can be used and, hence, economical laboratory experiments in transient effects can be designed for school laboratories.

7. Spectrum Generation: The Unit Pulser, either (1) alone, (2) with an r-f modulator, or (3) with a gated oscillator, will produce a pulse- or pulse-modulated-signal spectrum.

In the first case the spectrum for a train of pulses is produced.⁴ This spectrum has lines with frequency intervals determined by the repetition rate, and with maxima and minima of amplitude determined by the pulse duration. If the pulse is triggered by a TYPE 1213-A Unit Crystal Oscillator, accurate calibration frequencies at harmonics of 100 kc and 10 kc can be generated over a wider frequency range than can be generated by the Unit Crystal Oscillator alone,

⁴Reference Data for Radio Engineers, 3rd ed., Federal Telephone and Radio Corp., I. T. T., 1949, p. 298.

and accurate time markers at 10- and 100-microsecond intervals can also be obtained.

The spectrum of the pulse-modulated r-f carrier of the second case is similar in line structure to that of the pulse train, but is translated to lie centered at the r-f frequency as symmetrical side-band components.⁵

This modulation can be conveniently accomplished with the TYPE 1000-P7 Balanced Modulator.⁶

Finally, the pulser can be used to switch an r-f oscillator so that the oscillator's output voltage is coherent with the pulse and many interesting and useful spectra can be produced.⁷

— R. W. FRANK

⁵Cherry, Colin, *Pulses and Transients in Communication Circuits*, Chapman & Hall, 1949, p. 149.

⁶To be described in next month's issue of the *Experimenter*.

⁷Hanel, Alwin, "Multichannel Control of U-H-F Oscillators," *Proc. I. R. E.*, Vol. 41, No. 1, January, 1953, p. 79.

SPECIFICATIONS

Pulse Repetition Rates:

30 c, 60 c, both synchronized to power line.
100 c, 200 c, 500 c, 1000 c, 2000 c, 5000 c,
10 kc, 20 kc, 50 kc, 100 kc, all $\pm 15\%$ or 20 c,
whichever is greater.

Pulse Durations: Continuous coverage in four ranges 0.2 to 60,000 μsec . Accuracy $\pm 15\%$ or 0.2 μsec , whichever is greater.

Pulse Shape: Rise time 0.05 μsec .

Fall time 0.15 μsec . with output terminals shunted by 15 μf and 1 M Ω .

The overshoot may be set to be less than 5% of one-half maximum amplitude and the top of the pulse is flat to within 5% of maximum amplitude at all durations.

External Synchronization:

With sine waves, 5 volts, rms, is adequate for continuous locking at frequencies up to 1 kc. Increasing voltages to 25 volts, rms, are neces-

sary to lock continuously to 100 kc. A 10-volt pulse will lock continuously from 0 to 25 kc.

Output Impedance: Approximately 200 ohms for positive pulses and 1500 ohms for negative pulses.

Open Circuit Output Voltage: 20 volts for pulses of either polarity.

Stability: No time jitter is visible when a full period is displayed on an oscilloscope.

Tubes: 6AH6, 6AK5, 6AN5, 6AL5, and two 12AT7.

Accessories Supplied: One multipoint connector, 10 : 1 200 Ω attenuator.

Power Supply: 300 volts, 55 ma; 6.3 volts, 2 a. TYPE 1203-A Unit Power Supply is recommended.

Dimensions: (Width) $10\frac{5}{8}$ x (height) $5\frac{3}{4}$ x (depth) $6\frac{1}{4}$ inches, over-all, not including power-line connector cord.

Net Weight: $5\frac{1}{4}$ pounds.

Type		Code Word	Price
1217-A	Unit Pulser*	AMASS	\$195.00
1203-A	Unit Power Supply	ALIVE	40.00

*Licensed under patents of the Radio Corporation of America. Patent Applied For.

