

OPERATING INSTRUCTIONS



TYPE 1205-B

ADJUSTABLE REGULATED

POWER SUPPLY

G E N E R A L R A D I O C O M P A N Y



OPERATING INSTRUCTIONS

TYPE 1205-B

**ADJUSTABLE REGULATED
POWER SUPPLY**

Form 1205-0100-C

April, 1965

G E N E R A L R A D I O C O M P A N Y
WEST CONCORD, MASSACHUSETTS, USA





Figure 1. Type 1205-B Adjustable Regulated Power Supply.

SPECIFICATIONS

Dc Output

Voltage: 0 to 300 V continuously adjustable, at 200 mA max.

Regulation: No load to full load, 0.1 V; ± 0.75 -V change for $\pm 10\%$ change in line voltage.

Bias Output

Voltage: -150 V dc fixed, at 5 mA max.

Regulation: No load to full load, 0.5 V; 2-V max change for $\pm 10\%$ change in line voltage.

Unregulated Ac Voltage: 2 circuits, each 6.3 V nominal, at 5 A, can be connected in series or parallel.

Meter Accuracy: Voltage, 2%; current, 5%.

120-cycle Ripple: Less than 1 mV.

Internal Impedance: Approximately $0.3 \Omega + 2 \mu\text{H}$ shunted by $4 \mu\text{F}$.

Power Required: 105 to 125 V, 60 c/s; 250 W at full load.

Accessories Supplied: Adaptor plug, spare fuses.

Mechanical Data: Unit-Instrument Cabinet (see page 258)

Width		Height		Depth		Net Weight		Shipping Weight	
in	mm	in	mm	in	mm	lb	kg	lb	kg
9½	245	5¼	135	8¼	210	15	7	26	12

U.S. Patent Nos. D187,740 and 2,942,172.



TYPE 1205-B

ADJUSTABLE REGULATED

POWER SUPPLY

1 INTRODUCTION

1.1 PURPOSE. The Type 1205-B Adjustable Regulated Power Supply (Figure 1) is a compact, high-efficiency, fast-response source of regulated power from 0 to 300 volts, up to 200 ma. The Type 1205-B also includes two 5-amp 6.3-volt supplies and a regulated -150-volt 5-ma bias supply.

1.2 DESCRIPTION.

1.2.1 CONTROLS. Three controls are mounted on the front panel: A POWER toggle switch with a standby (B + OFF) position, a METER toggle switch to select either a voltage or a current meter indication, and an OUTPUT VOLTAGE control, by which the output voltage may be varied from 0 to full voltage.

1.2.2 CONNECTORS. The front-panel output connectors are all jack-top binding posts. The three on the right-hand end are, from top to bottom, the B+, B- (or bias +), and bias (-) connectors. A binding post adjacent to the B+ and B- posts permits grounding either B+ or B-. Two pairs of binding posts, labeled 6.3 v, are the terminals for the two ac heater supplies. These terminals may be connected for either series or parallel operation (refer to paragraph 3.2).

The line-voltage cable is attached to the power supply at the left side of the instrument.

Unit Instruments being powered by the Type 1205-B may be plugged directly into the multipoint connector at the right-hand side of the power supply. Connections are shown in Figure 7.

2 PRINCIPLES OF OPERATION

2.1 GENERAL. (See Figure 2). The Type 1205-B consists basically of two parts: a series-tube regulator, and a thyatron control rectifier. The series regulator provides fast response, low-drift, and low output impedance over a wide frequency range. The usual high dissipation of such a circuit is averted by use of a thyatron control rectifier, which maintains a constant voltage drop across the series regulator.

GENERAL RADIO COMPANY

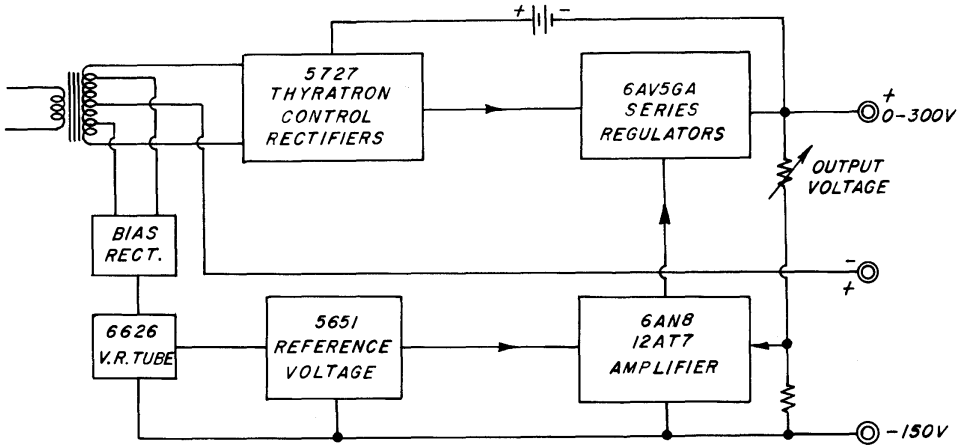

Figure 2. Block Diagram of Power Supply.

2.2 CIRCUIT DESCRIPTIONS. (See Figure 7.)

2.2.1 THYRATRON CONTROL RECTIFIER (V2, V3). A center-tapped high-voltage winding (terminals 5, 7, 9) provides plate voltage for the full-wave thyatron rectifier (V2, V3).

Control is obtained by a variation of the thyatron bias through a dc feedback path from the regulated output to the thyatron grids. Superimposed on this dc feedback is an ac bias voltage phase-shifted 90 degrees from the thyatron plate voltage for smooth control of the thyatron firing angle. A voltage source (RX5, C1) in the feedback path determines the voltage drop across the series regulator. The peak current in each thyatron is limited by a section of inductor L1.

The filtered output (C8, C9) of each half-wave rectifier supplies the series regulator circuit.

2.2.2 SERIES REGULATOR CIRCUIT (V4, V5, V6, V7, V8, V9). Power from the thyatron rectifiers is applied to the plates of the series regulator tubes (V4, V5). The two half-wave voltages are combined to provide 120-cps ripple at the screens of these tubes. The output from V4 and V5 is applied to the output binding posts and to a voltage divider (R51, R45, R57, R46, R59, R48).

A fraction of the output voltage (determined by the setting of the OUTPUT VOLTAGE control, R45) is applied to one grid (pin 7, V7) of the differential cascode amplifier (V7 and pentode section of V6). A reference voltage from V8 and V9 is applied to the other grid (pin 2, V7), and the voltages at the two grids are compared to produce a difference voltage. The amplified difference voltage (at pin 6 of V6) is applied through a cathode follower (triode section of V6) to

TYPE 1205-B ADJUSTABLE REGULATED POWER SUPPLY

the grids of the series regulator tubes, V4 and V5, to maintain constant output voltage. The output of the power supply is thus controlled by a negative feedback loop.

Part of the output from the cathode follower (pin 3, V6) is connected back to the reference grid (pin 2, V7) of the differential amplifier, providing positive feedback within the negative feedback loop. The amount of positive feedback is selected to achieve essentially infinite gain in the amplifier, and thus to provide approximately zero output impedance.

2.2.3 NEGATIVE VOLTAGE SUPPLY. Selenium rectifiers, connected to taps on the high-voltage secondary of the power transformer, provide negative voltage, which is filtered and regulated at -150 volts by V8. This supply powers the differential amplifier and the reference tube V9, and affords a negative bias supply at the front panel.

2.2.4 PROTECTIVE CIRCUITS. To keep the thyratrons from conducting until their cathodes have warmed up, the thyatron grids are returned to the -220-volt supply through a 120-volt source (RX5, C1), keeping the grids at about -100 volts until the cathode follower section of V1 conducts. The delay time is controlled by a resistor (R4) in the heater of V1. When the cathode follower conducts, the thyatron grids are connected to the regulated output voltage through the 120-volt source, and the thyratrons conduct.

If a failure in the amplifier caused loss of bias on the series regulator tubes, the output voltage would rise. Since any increase in output voltage is fed back to the controlled rectifier, the output would continue to rise to maximum, about 400 volts. To prevent such runaway action, an auxiliary regulator circuit controls output from the thyratrons in case of failure in the series regulator circuit. When the output voltage rises beyond the level set by the OUTPUT VOLTAGE control, the voltage rise at R57 is applied to the amplifier section of V1. This section, normally off, then conducts, controlling the firing angle of the thyratrons and thus the output voltage.

A third fail-safe feature is the use of series filaments in the two sections of V1. Thus, if the heater of the protective amplifier fails, the heater of the cathode follower section will be cut off, reducing output voltage to zero.

Any abnormal temperature rise in the power supply causes a thermal breaker (F3) to open, removing all power. The breaker automatically resets after a few minutes.

3 OPERATING PROCEDURE

3.1 MOUNTING. The Type 1205-B may be either bench mounted or mounted in a relay rack by means of a Type 480-PU3 Adaptor Panel. Make sure that proper ventilation exists, especially at the fan air intake at the rear.

GENERAL RADIO COMPANY

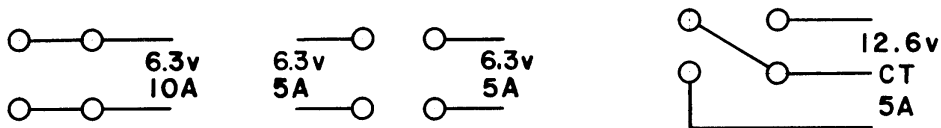

Figure 3. 6.3- and 12.6-Volt Connections.

3.2 OPERATION. To operate the Type 1205-B, simply plug the line connector into a 115-volt, 60-cps source, connect the device to be powered to the appropriate terminals for the voltages desired, and flip the POWER switch to ON.

A standby (B^+ OFF) position of the POWER switch allows the user to remove B^+ without turning off heater or bias voltages.

The heater terminals may be interconnected for either 6.3-v or 12.6-v operation, as shown in Figure 3.

NOTE

When this power supply is used with General Radio Unit instruments, the panel grounding link should be disconnected.

4 SERVICE AND MAINTENANCE.

4.1 GENERAL. This service information should enable the user to locate and correct ordinary difficulties resulting from normal use. Major service problems should be referred to our Service Department, which will cooperate as much as possible by furnishing information and instructions as well as by supplying any replacement parts needed.

When notifying our Service Department of any difficulties in operation or service, specify the serial and type numbers of the instrument. Also give a complete report of trouble encountered and steps taken to eliminate the trouble.

Before returning an instrument or parts for repair, please write to our Service Department, requesting a Returned Material Tag, which includes shipping instructions. Use of this tag will insure proper handling and identification. A purchase order covering material returned for repair should also be forwarded to avoid unnecessary delay.

4.2 REMOVAL OF COVER AND ETCHED BOARD. To remove the cover of the Power Supply, first remove four screws, one in each of the upper and lower rear corners of both side panels of the instrument. The cover can then be pulled back, away from the panel.

TYPE 1205-B ADJUSTABLE REGULATED POWER SUPPLY

If it becomes necessary to move the etched board to the servicing position, remove both screws in the right rear upper and lower corners. Then remove the four screws that attach the transformer (T1) to the front panel. The etched board and transformer can then be removed for servicing. The instrument is operable in this position, as all cables remain connected. However, care must be used when handling the instrument so that the etched board will not be damaged.

4.3 TROUBLE-SHOOTING PROCEDURE.

4.3.1 INCORRECT VOLTAGE AT -150-VOLT BIAS SUPPLY. If the bias voltage is high, replace V8 (Type 6626). If the bias voltage is low, check the voltages across C14 and C15. If the voltage across C14 is normal but that across C15 is low, check for a short in capacitor C15 or along the -150-volt bias bus. Check for an open R27. If voltages across C14 and C15 are both low, check for a shorted C14 or open R26 or defective rectifiers RX1, RX2, RX3, or RX4. Use the schematic diagram (Figure 7) to determine normal operating voltages.

4.3.2 0-300-VOLT SUPPLY INOPERATIVE. If the output voltage is zero and does not change when the OUTPUT VOLTAGE control is rotated, check that S1 is in the ON position rather than at B+ OFF (Standby). If the fan is not operating, check fuses F1 and F2, located on the etched circuit board. If the fuses are good, check thermal breaker F3. If this has overheated, it will reset in a few minutes.

Check the protective circuit V1 (6BZ7). Voltage at the cathode (pin 8) of V1 should be slightly positive with respect to the grid (pin 7). If this voltage is not positive, and if at least 100 volts (with respect to B-) is present at the plate (pin 6), replace V1. Heater voltage between pins 4 and 5 should be 3.8 volts ac.

Check for approximately 120 volts across C1. The voltage at pin 1 of V1 should be at least +100 volts with respect to B+ (regulated output).

Check the cascode differential amplifier. A failure in the triode section of V6 (6AN8) can completely cut off the series tubes V4 and V5 (6AV5GA). Replace V6 if the voltage at the cathode pin (pin 3) of V6 is negative with respect to B-.

Measure the voltages from C8 and from C9 to B-. If these are less than +100 volts, check thyratrons V2 and V3, and check C8 and C9 for an open or short circuit.

Check the series regulator tubes, V4 and V5. Check that the resistance from the cathode (pin 3) of V4 or V5 to the positive output terminal is approximately 82 ohms.

4.3.3 0-300-VOLT SUPPLY ADJUSTABLE BUT WITH EXCESSIVE RIPPLE AND POOR REGULATION. A failure in the pentode section of V6 (12AT7) or in one half (pins 6, 7, and 8) of V7 (12AT7) would permit no current to flow through the cascode amplifier plate resistor R40, and therefore would bring the series tubes V4 and V5 to zero bias. This would cause the output voltage to be

20 to 40 volts higher than normal, with excessive ripple and poor regulation. The voltage at anchor terminal 40 (junction of R46, R57, and R58; see Figure 5) would vary from 0 to -17 volts as the OUTPUT VOLTAGE setting is changed, instead of the constant -25 volts normally measured at this point. This rise in voltage at anchor terminal 40 will cause the amplifier section of the protective circuit V1 (6BZ7) to conduct, limiting the rise in output voltage as explained in paragraph 2.2.4. This kind of failure is readily detected from the excessive ripple that exists when the supply is even lightly loaded and from the improper operating voltages at anchor terminal 40. Measurement of the voltages at V7 and at the pentode section of V6 should locate the source of the trouble.

A failure in the reference voltage amplifier half (pins 1, 2, and 3) of V7 will cause the voltage at anchor terminal 40 to vary from -25 to -65 volts as the OUTPUT VOLTAGE setting is changed, and the output voltage from the 0-300-volt supply will not go above 100 volts.

4.3.4 0-300-VOLT SUPPLY OPERATES CORRECTLY FOR SMALL LOADS BUT CANNOT SUPPLY FULL LOAD OR DOES SO ONLY WITH EXCESSIVE RIPPLE. If the ripple is mostly at 60 cycles, one of the series regulator tubes, V4 or V5, may have low emission or may be inoperative. Also check thyratrons V2 and V3. Prolonged operation with an inoperative series regulator tube or thyatron at load currents above 100 ma will usually shorten the life or degrade the performance of one of the thyratrons.

Check that the voltage across C1 is 133 volts. Measure the voltage at pin 1 of V1. This should be at least +110 volts with respect to B⁺ (regulated output).

4.4 ZERO-SET ADJUSTMENT. If the output voltage is not zero when the OUTPUT VOLTAGE control is set at minimum (fully counterclockwise), open the instrument and set the voltage to zero with the screw-driver adjustment R59 (see Figure 4). Note that, because of the presence of diode RX6, the output voltage cannot be set to more than a few tenths of a volt negative; therefore, the correct setting of R59 is that at which the voltage just reaches zero from a positive value.

4.5 LUBRICATION. The fan motor should be lubricated with light machine oil (SAE 20 to SAE 30) every two to six months of operation. There is an oil port in the shaft of the motor for this purpose.

7

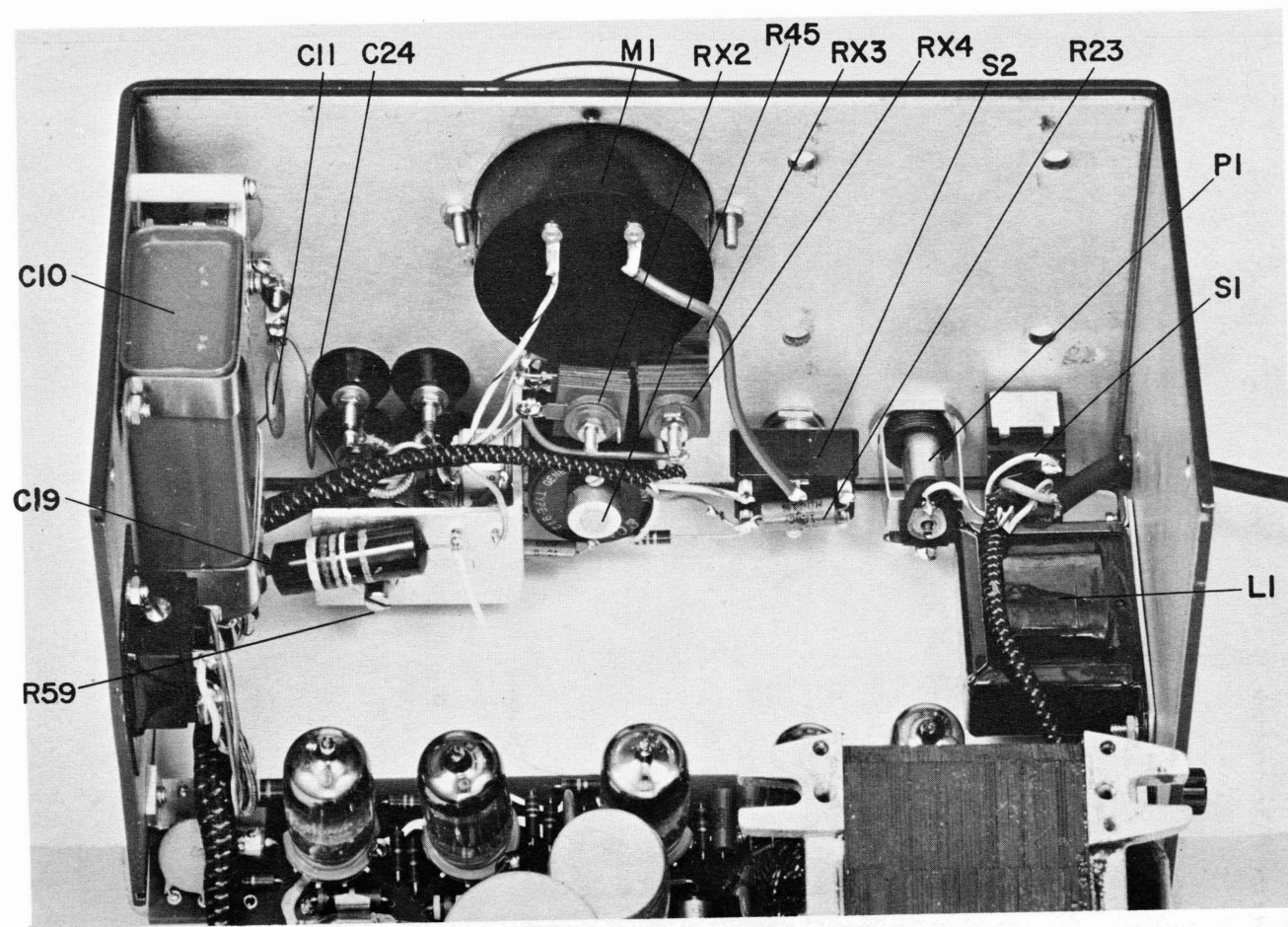

Figure 4. Top Interior View with Etched Board in Servicing Position.

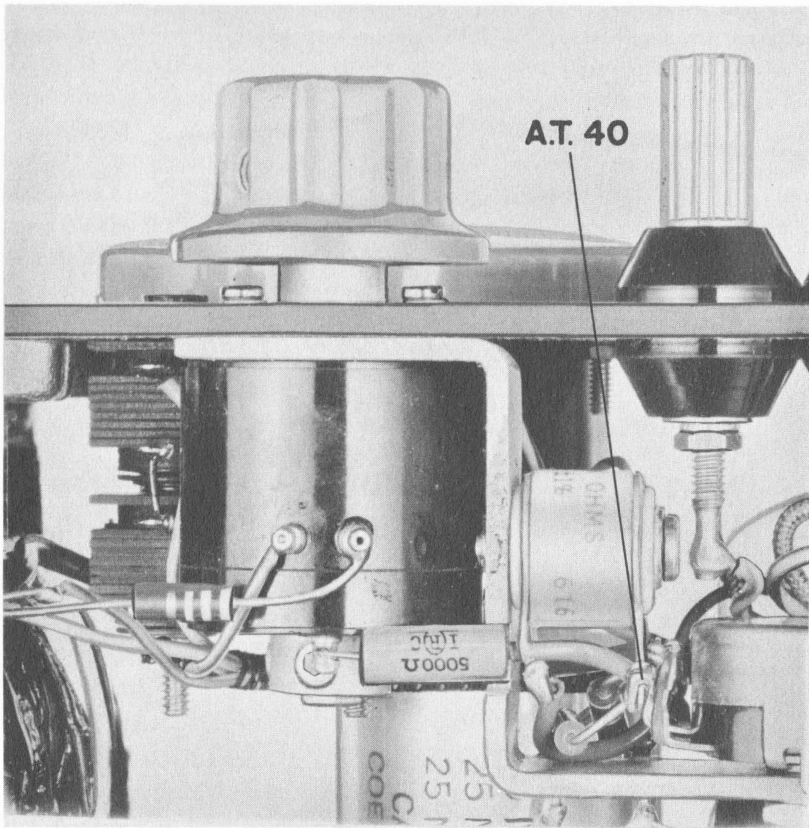

Figure 5. Partial Bottom Interior View Showing Location of Anchor Terminal 40.

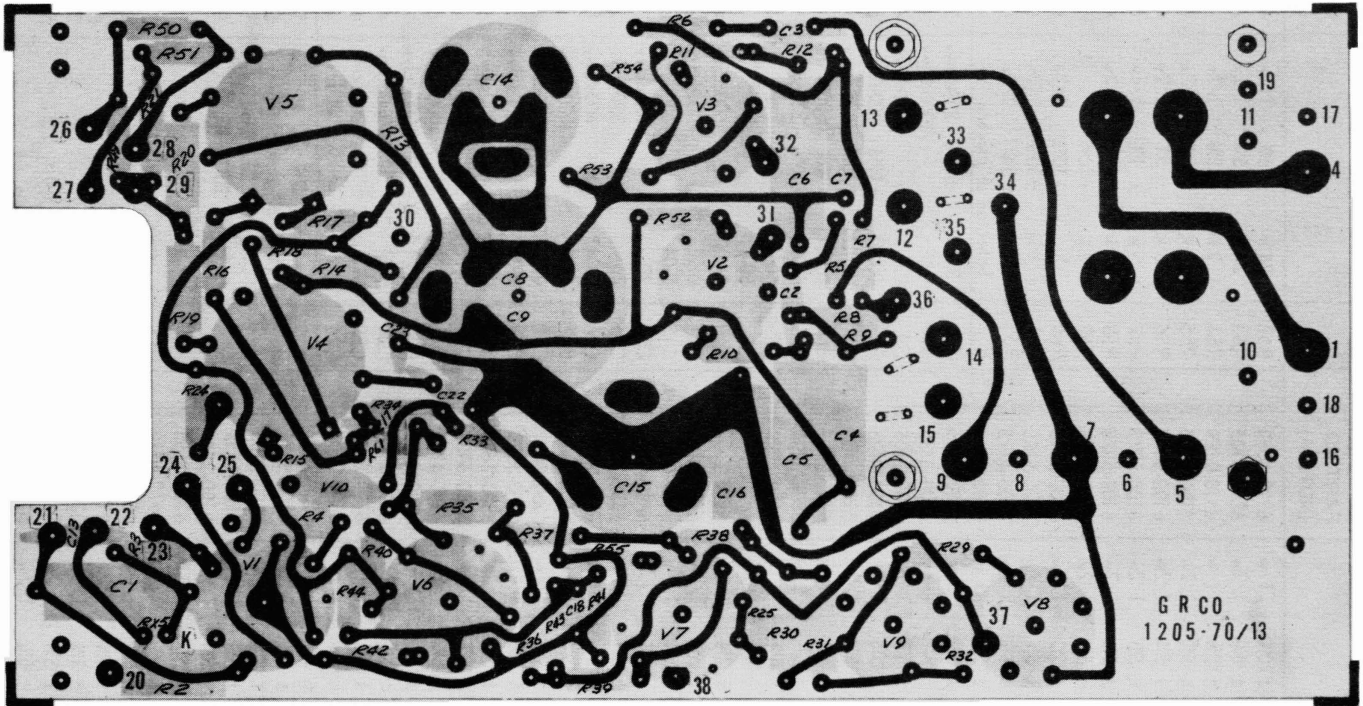

Figure 6. Etched Board Layout Diagram.



TYPE 1205-B ADJUSTABLE REGULATED POWER SUPPLY

PARTS LIST

				PART NO. (NOTE A)				PART NO. (NOTE A)			
RESISTORS (NOTE B)	R2	560 k	±10%	1 w	6110-4569	R52	24 k	± 5%	1/2w	6100-3245	
	R3	1 M	± 5%	1/2w	6100-5105	R53	24 k	± 5%	1/2w	6100-3245	
	R4	6.8	±10%	1 w	6110-9689	R54	1 M	± 5%	1/2w	6100-5105	
	R5	4.7 M	± 5%	1/2w	6100-5475	R55	15 k	± 5%	1/2w	6100-3155	
	R6	4.7 M	± 5%	1/2w	6100-5475	R56	33 k	± 5%	1/2w	6100-3335	
	R7	2.7 M	± 5%	1/2w	6100-5275	R57	5 k	± 1%	1/4w	6350-1500	
	R8	2.7 M	± 5%	1/2w	6100-5275	R58	1 M	± 5%	1/2w	6100-5105	
	R9	470 k	± 5%	1/2w	6100-4475	R59	5 k	±10%		6050-1700	
	R10	1 M	± 5%	1/2w	6100-5105	R60	15	±10%	1/2w	6760-0159	
	R11	1 M	± 5%	1/2w	6100-5105	R61	1 M	±10%	1/2w	6100-5105	
	R12	470 k	± 5%	1/2w	6100-4475	R62	10k	±5%	1/2w	6100-3105	
	R13	1 k	± 5%	3 w	6680-2105	R63	Selected at factory				
	R14	1 k	± 5%	3 w	6680-2105	CAPACITORS (NOTE C)	C1	0.1	±10%	200dcwv	5010-0700
	R15	1 k	± 5%	1/2w	6100-2105		C2	0.01		1000dcwv	4406-3109
	R16	1 k	± 5%	1/2w	6100-2105		C3	0.01		1000dcwv	4406-3109
	R17	100	± 5%	1/2w	6100-1105		C4	0.022	±10%	200dcwv	5010-0500
	R18	100	± 5%	1/2w	6100-1105		C5	0.0022	±10%	600dcwv	4510-4100
	R19	82	± 5%	3 w	6680-0825		C6	0.0022	±10%	600dcwv	4510-4100
	R20	82	± 5%	3 w	6680-0825		C7	0.022	±10%	200dcwv	5010-0500
	R21	0.555	± 1%		6690-1700		C8	50		450dcwv	4450-0800
	R22	25 k	± 5%	10 w	6670-3255		C9	50			4450-0800
	R23	400 k	± 1%	1/2w	6450-3400		C10	3	±10%	600dcwv	4510-1100
	R24	10 M	± 5%	1/2w	6100-6105		C11	0.01		1000dcwv	4406-3109
	R25	10 M	± 5%	1/2w	6100-6105		C13	0.01		1000dcwv	4406-3109
	R26	100	± 5%	5 w	6660-1105		C14	30		350dcwv	4450-3500
	R27	1.8 k	± 5%	10 w	6670-2185		C15	30		350dcwv	4450-3500
	R28	1.8 k	± 5%	10 w	6670-2185		C16	0.047	±10%	400dcwv	5020-1000
	R29	30 k	± 5%	1/2w	6100-3305		C17	0.01		1000dcwv	4406-3109
	R30	600 k	± 1%	1/4w	6350-3600		C18	0.01		1000dcwv	4406-3109
	R31	270 k	± 1%	1/4w	6350-3270		C19	0.047	±10%	600dcwv	4510-4200
	R32	4.7 k	± 5%	1/2w	6100-2475		C20	0.22	±10%	200dcwv	5010-0800
	R33	1 M	± 5%	1/2w	6100-5105		C21	0.01		1000dcwv	4406-3109
	R34	100 k	± 5%	1/2w	6100-4105		C22	0.01		1000dcwv	4406-3109
	R35	470 k	± 5%	1 w	6110-4479		C23	0.01		1000dcwv	4406-3109
	R36	18 k	± 5%	1/2w	6100-3185		C24	0.01		1000dcwv	4406-3109
	R37	8.2 M	± 5%	1/2w	6100-5825		C25	470 μμf		1000dcwv	4404-1479
	R38	1 k	± 5%	1/2w	6100-2105		C26	470 μμf		1000dcwv	4404-1479
	R39	10 k	± 5%	1/2w	6100-3105		ELECTRICAL COMPONENTS	BL1	FAN MOTOR		
	R40	2.7 M	± 5%	1/2w	6100-5275	F1		FUSE, 2.5 amp Slo-Blo			5330-2100
	R41	20 k	± 5%	1/2w	6100-3205	F2		FUSE, 2.5 amp Slo-Blo			5330-2100
	R42	15 k	± 5%	1/2w	6100-3155	F3		CIRCUIT BREAKER, Thermal			5320-1400
	R43	56 k	± 5%	1/2w	6100-3565						
	R44	1.5 M	± 5%	1/2w	6100-5155						
	R45	68 k	± 2%		0972-4030	L1		CHOKE			0745-4180
	R46	15 k	± 1%	1/3w	6700-2100	L2		CHOKE			4290-3400
	R47	220 k	± 5%	1/2w	6100-4225	L3		CHOKE			4290-3400
	R48	7 k	± 1%	1/3w	6700-1400	M1		METER			5730-0980
	R49	10	± 5%	1/2w	6100-0105	P1	PILOT LAMP, 6.3 v Mazda No. 44			5600-0700	
	R50	1.8 k	± 5%	1/2w	6100-2185						
	R51	100	± 5%	1/2w	6100-1105						

SCHEMATIC DIAGRAM
FOR
1205-B ADJUSTABLE REGULATED POWER SUPPLY

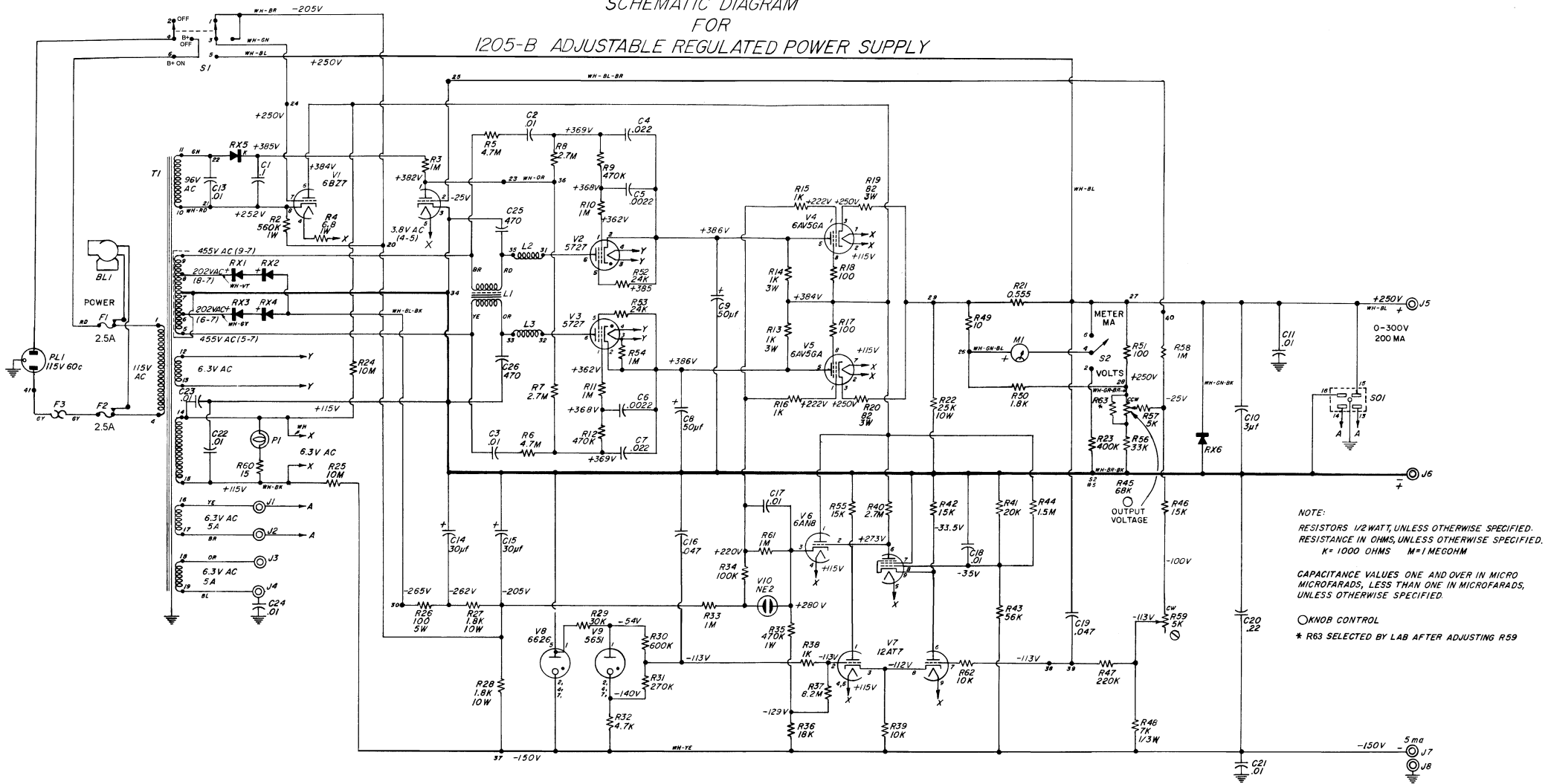

NOTE:
RESISTORS 1/2 WATT, UNLESS OTHERWISE SPECIFIED.
RESISTANCE IN OHMS, UNLESS OTHERWISE SPECIFIED.
K = 1000 OHMS M = 1 MEGOHM

CAPACITANCE VALUES ONE AND OVER IN MICRO MICROFARADS, LESS THAN ONE IN MICROFARADS, UNLESS OTHERWISE SPECIFIED.

KNOR CONTROL
* R83 SELECTED BY LAB AFTER ADJUSTING R59

Figure 7. Schematic Diagram.

PARTS LIST (CONT)

		PART NO. (NOTE A)
RX1	RECTIFIER	2RE-31
RX2	RECTIFIER	2RE-31
RX3	RECTIFIER	2RE-31
RX4	RECTIFIER	2RE-31
RX5	RECTIFIER	2RE-40
RX6	RECTIFIER	2RE-1002
S1	SWITCH, Power	SWT-13NP
S2	SWITCH, Meter	SWT-335NP
T1	TRANSFORMER	365-485

NOTES:

(A) Type designations for resistors and capacitors are as follows:

- COC - Capacitor, ceramic
- COE - Capacitor, electrolytic
- COL - Capacitor, oil
- COW - Capacitor, wax
- POSW - Potentiometer, wire-wound
- REC - Resistor, composition
- REF - Resistor, film

- REPO - Resistor, power
- REPR - Resistor, precision
- REW - Resistor, wire-wound

(B) All resistances are in ohms, except as otherwise noted by k (kilohms) or M (megohms).

(C) All capacitances are in microfarads, except as otherwise noted by $\mu\mu\text{f}$ (micromicrofarads).

TUBES

V1	6BZ7	V6	6AN8
V2	5727	V7	12AT7
V3	5727	V8	6626
V4	6AV5GA	V9	5651
V5	6AV5GA	V10	NE2

GENERAL RADIO COMPANY

WEST CONCORD, MASSACHUSETTS, * 01781

617 369-4400

617 646-7400

SALES ENGINEERING OFFICES

METROPOLITAN NEW YORK*

Broad Avenue at Linden
Ridgefield, New Jersey, 07657
Telephone N.Y. 212 964-2722
N.J. 201 943-3140

SYRACUSE

Pickard Building
East Molloy Road
Syracuse, New York, 13211
Telephone 315 454-9323

PHILADELPHIA

General Radio Company
Fort Washington Industrial Park
Fort Washington, Pennsylvania 19034
Telephone 215 646-8030

WASHINGTON* AND BALTIMORE

Rockville Pike at Wall Lane
Rockville, Maryland, 20852
Telephone 301 946-1600

ORLANDO

113 East Colonial Drive
Orlando, Florida, 32801
Telephone 305 425-4671

* Repair services are available
at these district offices.

CHICAGO*

6605 West North Avenue
Oak Park, Illinois, 60302
Telephone 312 848-9400

CLEVELAND

5579 Pearl Road
Cleveland, Ohio, 44129
Telephone 216 886-0150

LOS ANGELES*

1000 North Seward Street
Los Angeles, California, 90038
Telephone 213 469-6201

SAN FRANCISCO

1186 Los Altos Avenue
Los Altos, California, 94022
Telephone 415 948-8233

DALLAS

2501-A West Mockingbird Lane
Dallas, Texas, 75235
Telephone 214 Fleetwood 7-4031

TORONTO*

99 Floral Parkway
Toronto 15, Ontario, Canada
Telephone 416 247-2171

MONTREAL

Office 395, 1255 Laird Boulevard
Town of Mount Royal, Quebec, Canada
Telephone 514 737-3673

General Radio Company (Overseas), 8008 Zurich, Switzerland
General Radio Company (U.K.) Limited, Bourne End, Buckinghamshire, England
Representatives in Principal Overseas Countries

