

OPERATING INSTRUCTIONS



TYPE 1217-C

UNIT PULSE GENERATOR

GENERAL RADIO COMPANY

B



File Courtesy of GRWiki.org

SPECIFICATIONS

PULSE REPETITION FREQUENCY

Internally Generated: 2.5 c/s to 1.2 Mc/s, with calibrated points in a 1-3 sequence from 10 c/s to 300 kc/s, and 1.2 Mc/s, all $\pm 5\%$. Continuous coverage with an uncalibrated control.

Externally Controlled: Aperiodic, dc to 2.4 Mc/s with 1 V, rms, input (0.5 V at 1 Mc/s and lower); input impedance at 0.5 V, rms, approximately 100 k Ω shunted by 50 pF. Output pulse is started by negative-going input transition.

OUTPUT-PULSE CHARACTERISTICS

Duration: 100 ns to 1 s in 7 decade ranges, $\pm 5\%$ of reading or $\pm 2\%$ of full scale or ± 35 ns, whichever is greater.

Rise and Fall Times: Less than 10 ns into 50 or 100 Ω ; typically 60 ns + 2 ns/pF external load capacitance into 1 k Ω (40 V).

Voltage: Positive and negative 40-mA current pulses available simultaneously. Dc coupled, dc component negative with respect to ground. 40 V, peak, into 1-k Ω internal load impedance for both negative and positive pulses. Output control marked in approximate output impedance.

Overshoot: Overshoot and noise in pulse, less than 10% of amplitude with correct termination. **Ramp-off:** Less than 1%.

Synchronizing Pulses:

Pre-pulse: Positive and negative 8-V pulses of 150-ns duration. If positive sync terminal is shorted, negative pulse can be increased to 50 V. Sync-pulse source impedance:

positive — approx 300 Ω ; negative — approx 1 k Ω .

Delayed Sync Pulse: Consists of a negative-going transition of approximately 5 V and 100-ns duration coincident with the late edge of the main pulse. Duration control reads time between prepulse and delayed sync pulse. This negative transition is immediately followed by a positive transition of approximately 5 V and 150 ns to reset the input circuits of a following pulse generator. (See oscillogram).

Stability: Prf and pulse-duration jitter are dependent on power-

1- μ s pulse into 50 ohms with delayed sync pulse.

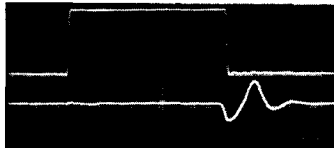

supply ripple and regulation. With TYPE 1201 Power Supply external-drive terminals short-circuited, prf jitter and pulse-duration jitter are each 0.01%. With TYPE 1203 Power Supply, they are 0.05% and 0.03%, respectively. (Jitter figures may vary somewhat with range switch settings, magnetic fields, etc.)

GENERAL

Power Required: TYPE 1203 or TYPE 1201 Unit Power Supply is recommended.

Accessories Available: TYPE 1217-P2 Single-Pulse Trigger, rack-adaptor panel for both generator and power supply (19 by 7 in).

MECHANICAL DATA Unit-Instrument Cabinet (see page 258)

	Width		Height		Depth		Net Wt		Ship Wt	
	in	mm	in	mm	in	mm	lb	kg	lb	kg
With power supply	15	385	5 3/4	150	6 1/2	165	9 1/2	4.4	12	5.5

See also *General Radio Experimenter*, December 1964.

TABLE OF CONTENTS

Section 1	INTRODUCTION	1
	1.1 Purpose	1
	1.2 General Description	1
	1.3 Controls and Connectors	2
	1.4 Accessories Supplied	3
	1.5 Accessories Required	3
	1.6 Accessories Available	3
Section 2	OPERATING PROCEDURE	4
	2.1 Installation	4
	2.2 Definition of Terms	6
	2.3 Normal Internal Operation	7
	2.4 Normal External Operation	8
	2.5 PRF vs Pulse Duration	10
	2.6 Precautions for Very Long or Very Short Pulses	12
	2.7 Rise and Fall Times	13
	2.8 External Load Considerations	13
	2.9 Output DC Component—DC Translation	14
	2.10 Locking on High-Frequency Signals	15
	2.11 Count-Down Operation	16
	2.12 Single-Pulse Operation	16
	2.13 Use as a Delay Generator	17
	2.14 Use for Complex Waveforms	18
Section 3	PRINCIPLES OF OPERATION	19
	3.1 General	19
	3.2 Input and PRF Oscillator Circuit - External Operation	20
	3.3 Input and PRF Oscillator Circuit - Internal Operation	21
	3.4 Output Pulse Circuit	22
Section 4	SERVICE AND MAINTENANCE	27
	4.1 Warranty	27
	4.2 Service	27
	4.3 Removal of Cover	28
	4.4 Trouble-Shooting Notes	28
	4.5 Waveforms	30
	4.6 Voltages and Resistances	31
	4.7 Calibration Procedure	32
	Parts Lists and Schematics	40





Type 1217-C Unit Pulse Generator.



Type 1217-C Unit Pulse Generator with Type 1201-C Unit Regulated Power Supply.

SECTION 1**INTRODUCTION****1.1 PURPOSE.**

The Type 1217-C Unit Pulse Generator is a general-purpose pulse source intended primarily for laboratory use. The repetition rates of the pulses may be either internally controlled, at frequencies from 2.5 cps to 1.2 Mc, or externally controlled at frequencies up to 2.4 Mc.

In addition to the main positive and negative output pulses, the instrument also supplies synchronizing pulses that correspond to the beginning and end of the main pulse. The early sync pulse ("prepulse") is intended chiefly for synchronizing an oscilloscope while the late pulse ("delay" pulse) is intended to make the instrument an accurate time-delay generator.

1.2 GENERAL DESCRIPTION.

The Type 1217-C comprises two main circuit groups:

(1) A combination input circuit and oscillator that establishes the repetition rate of the main pulse.

(2) A combination pulse-timing and output circuit that establishes the duration and amplitude of the main pulse.

The repetition frequency, duration, and amplitude of the main output pulse are adjustable by front-panel controls. The instrument is housed in a compact unit-type cabinet designed for bench mounting. It can also be rack-mounted with a unit power supply by means of a relay-rack adaptor panel (refer to paragraph 2.1.6).

**1.3 CONTROLS AND CONNECTORS.**

See Figure 1-1 and Table 1-1 for the location and the description of the controls and connectors used on the Type 1217-C.

TABLE 1-1.
CONTROLS AND CONNECTORS

<i>Reference (Figure 1-1)</i>	<i>Name</i>	<i>Type</i>	<i>Function</i>
1	PRF	12-position rotary switch	Sets PRF range. In EXT DRIVE, it changes prf oscillator to an aperiodic input circuit.
2	ΔF	Continuous rotary switch	Adjusts prf continuously between calibrated switch positions. When set fully clockwise, PRF switch is calibrated. When PRF switch is set to EXT DRIVE, ΔF control sets triggering level of pulse generating circuits.
3	PULSE DURATION	Continuous rotary dial (no stop)	Sets pulse duration.
4	PULSE DURATION RANGE	7-position rotary switch	Sets pulse duration range.
5	AMPLITUDE	Continuous rotary control	Sets pulse amplitude and output impedance. Calibrated in approximate impedance (ohms).
6	OUTPUT PULSE -	Jack-top binding post pair	For negative main output pulse.
7	OUTPUT PULSE +	Jack-top binding post pair	For positive main output pulse.
8	SYNC DELAYED	Jack-top binding post pair	For delayed sync pulse. Amount of delay is controlled by PULSE DURATION controls.
9	SYNC -	Jack-top binding post pair	For negative prepulse.
10	SYNC +	Jack-top binding post pair	For positive prepulse.
11	EXT DRIVE	Jack-top binding post pair	For external drive signal.
12	--	5-terminal male connector	For power input.



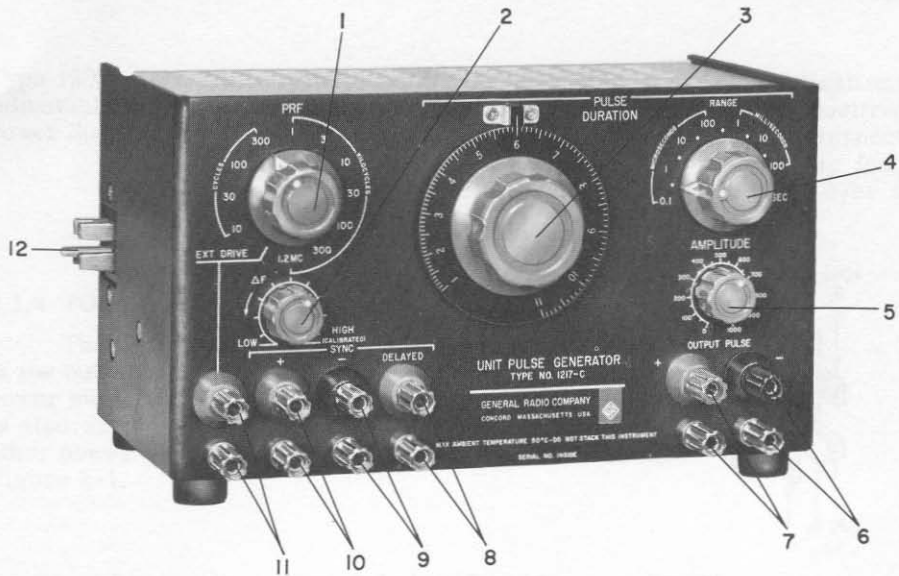

Figure 1-1. Type 1217-C Unit Pulse Generator.

1.4 ACCESSORIES SUPPLIED.

One instruction book, code number 1217-0130.

Two locking strips, code number 1200-0800. Used to attach the pulse generator rigidly to the power supply. Refer to paragraph 2.1.5 for further details.

1.5 ACCESSORIES REQUIRED.

Power supply. Refer to paragraph 2.1.3 for further details.

1.6 ACCESSORIES AVAILABLE.

Type 1217-P2 Single-Pulse Trigger, code number 1217-9602. Used to generate single pulses. See Figure 1-2 and paragraph 2.12.4 for further details.

Type 480-P4U3 Relay-Rack Adaptor Set, code number 0480-9986. Used to rack-mount the Type 1217-C. Refer to paragraph 2.1.6 for further details.



Figure 1-2. Type 1217-P2 Single Pulse Trigger.



SECTION 2

OPERATING PROCEDURE

2.1 INSTALLATION.

2.1.1 COOLING.

It is important that the interior of the instrument be adequately ventilated; therefore make sure the air holes in the cover are not blocked.

2.1.2 POWER SUPPLY REQUIREMENTS.

- 300 volts dc at 60 milliamperes.
- 6.3 volts ac at 3 amperes.

Neither positive nor negative dc-supply terminals should be connected to the chassis of the Type 1217-C.

2.1.3 POWER SUPPLIES RECOMMENDED.

- Type 1201 Recommended if jitter requirements are critical. The low dc ripple of the Type 1201 produces less time jitter of both the pulse period and pulse duration.
- Type 1203 Recommended if jitter requirements are not critical. The Type 1203 is not regulated.



Type 1205..... Recommended in some special applications where it is desirable to regulate both positive and negative supplies separately with respect to ground (as, for instance, where pulse load impedance is to be externally adjusted over a wide range).

Adjustable Regulated Power Supply

2.1.4 POWER SUPPLY CONNECTIONS.

The power input connector on the left-hand side of the pulse generator mates directly with any of the unit power supplies mentioned above. A mating connector is also supplied with the pulse generator for use with other power supplies. Input connections are shown in Figure 2-1.

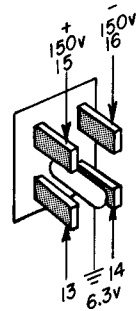

Figure 2-1. Input Power Connector, PL-101.

2.1.5 BENCH MOUNTING.

The Type 1217-C can be rigidly attached to the power supply by means of two stainless-steel locking strips supplied (code number 1200-0800 each). One strip is used at the top and the other at the bottom as shown in Figure 2-2. It may be necessary to remove the dust covers of the instruments and to slide the covers and strips in place simultaneously.

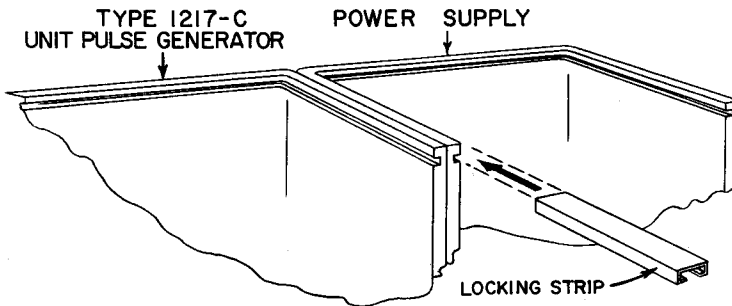

Figure 2-2. Rigidly mounting the power supply to the Type 1217-C.

2.1.6 RACK-MOUNTING.

The Type 1217-C may be rack-mounted with either the Type 1201 or 1203 Power Supply by means of a Type 480-P4U3 Relay-Rack Adaptor Set (code number 0480-9986). The adaptor panel is finished in charcoal gray



cracklepaint to match the front panel of the instruments and comes complete with the necessary hardware to mount the instruments in the panel. To make the installation proceed as follows:

- a. Use the locking strips to attach the pulse generator rigidly to the power supply (refer to paragraph 2.1.5).
- b. Mount the instruments in the adaptor panel by means of the tee bolts and associated hardware as shown in Figure 2-3.
- c. Mount the assembly in the relay rack.

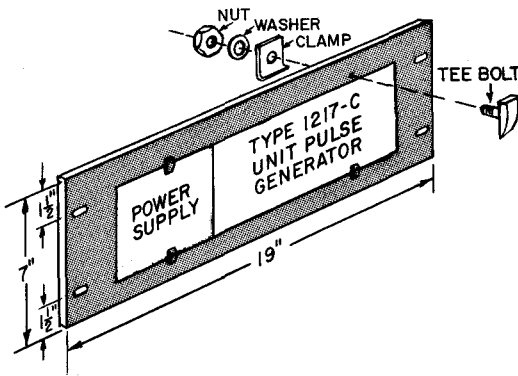

Figure 2-3. Rack-mounting the Type 1217-C/ power supply combination by means of a Type 480-P4U3 Relay-Rack Adapter Set.

2.2 DEFINITION OF TERMS.

- main pulse..... The principal output of the instrument; available at the OUTPUT PULSE binding posts.
- prepulse..... The positive or negative sync pulse supplied just before the start of the main pulse; available at the SYNC + and SYNC - binding posts.
- delayed pulse..... The pulse coincident with the end of the main pulse; available at the DELAYED binding posts.
- internal operation..... The mode where pulse repetition frequency is determined by the pulse generator itself and controlled by the PRF controls on the front panel.
- external operation..... The mode where pulse repetition frequency is determined by an external signal source; the pulse generator generates pulses only when triggered by signals applied to the EXT DRIVE binding posts.
- duty ratio..... The ratio of pulse "on" time to the total time of the period established by the prf setting; duty ratio, in percent = $\text{prf} \times \text{duration} \times 100$.



2.3 NORMAL INTERNAL OPERATION.

2.3.1 PRF ADJUSTMENT.

Pulse repetition frequency is adjusted by the PRF controls (1 and 2, Figure 1-1), over a range of 2.5 cps to 1.2 Mc. The PRF switch is calibrated to indicate prf correctly only when the ΔF control is fully clockwise. When the ΔF control is fully counterclockwise, the prf is lowered well below the next lower PRF switch setting. The range of adjustment of the ΔF control is more than enough to span any one of the ranges set by the PRF switch, and thus affords continuous coverage of the prf range of 2.5 cps to 1.2 Mc. It is important to remember, however, that the only calibrated frequencies are those indicated by the PRF switch positions, and that these are accurate only when the ΔF control is fully clockwise.

2.3.2 PULSE DURATION ADJUSTMENT.

Duration of the main pulse is adjusted by the PULSE DURATION controls (3 and 4, Figure 1-1). The RANGE switch (4) selects one of seven decade ranges and the range selected is covered by the PULSE DURATION dial (3). This control consists of a knob linked by a slow-motion drive to a dial that is calibrated from 1 to 11 in tenths of a unit. The overlap beyond the decade span ensures continuous coverage of all durations.

2.3.3 AMPLITUDE ADJUSTMENT.

Amplitude of the main pulse is adjusted by the AMPLITUDE control. Since output amplitude is directly proportional to output impedance, the control is calibrated in approximate output impedance. When this control is fully clockwise, the amplitude is 40 volts and the output impedance is 1 kilohm.

2.3.4 FAMILIARIZATION PROCEDURE.

The best way to become familiar with the pulse generator is to connect it to an oscilloscope and watch the pulses themselves. The procedure is as follows:

- a. Connect the OUTPUT PULSE + binding post to the oscilloscope vertical input by means of open leads or a probe.
- b. Connect the SYNC + binding post to the oscilloscope sync or trigger input.
- c. Connect any of the ground binding posts to the oscilloscope ground.
- d. Adjust the oscilloscope trigger controls to trigger on the 8-volt, 100-nsec, positive prepulse of the Type 1217-C.
- e. Set the oscilloscope sweep rate controls for a 200- μ sec/div sweep rate.
- f. Set the oscilloscope vertical gain controls for about 20 volts/cm sensitivity.
- g. Set the PRF switch to 1 kc.



- h. Set the ΔF control fully clockwise.
- i. Set the PULSE DURATION dial to 5.
- j. Set the PULSE DURATION RANGE switch to 100 μsec -1 msec.
- k. Set the AMPLITUDE control fully clockwise.

The oscilloscope should now display a 1-kc square-wave from the pulse generator. Use the PULSE DURATION dial to shorten and lengthen the pulse and then set the PULSE DURATION RANGE switch to the next lower range. Decrease the prf first by turning the ΔF control counterclockwise and then by setting the PRF switch to the next lower position. Adjust the oscilloscope sweep rate control to keep both the pulse duration and frequency under observation. To decrease pulse amplitude, turn the AMPLITUDE control counterclockwise.

If the oscilloscope has a dc-coupled vertical amplifier, set it for dc, disconnect the pulse, and establish the ground reference trace. Now reconnect the positive main pulse and vary its amplitude. Then move the connector from the + OUTPUT PULSE to the - OUTPUT PULSE binding post and vary the amplitude again. Note that the pulse contains a dc component that is negative with respect to ground. The positive pulse starts from -40 volts and rises to ground during its active interval. The negative pulse starts from ground and falls to -40 volts during its active interval.

If, during any of the above procedures, the pulse is defective or the pattern becomes confused, check to make sure that the pulse duration has not been made too long for the pulse repetition frequency. The Type 1217-C can produce pulses of very long duration. To observe these properly, an oscilloscope with a dc-coupled vertical amplifier must be used.

2.4 NORMAL EXTERNAL OPERATION.

2.4.1 DRIVING SIGNAL REQUIREMENTS.

The Type 1217-C will produce externally triggered pulses at frequencies from dc to 2.4 Mc. The driving signal should be applied to the EXT DRIVE terminals, and should be at least 0.5 volt rms up to 500 kc and at least 1 volt rms from 500 kc to 2.4 Mc. Excessive driving voltages at frequencies above 1.5 Mc may overload the triggering circuits. If the unit fails to trigger, reduce the driving voltage. With optimum driving voltage the unit will trigger to frequencies typically as high as 2.5 Mc.

2.4.2 EXTERNAL DRIVE PROCEDURE.

For external operation, set the PRF switch to EXT DRIVE and apply the external driving signal to the EXT DRIVE binding posts. The ΔF control now becomes a triggering level adjustment; the input circuits are set for maximum sensitivity when this control is centered.

The input circuit is dc-coupled, and the pulse generator will operate from pulses at any low frequency desired. The input signal must therefore either be at a dc potential close to ground or be ac-coupled, with an external blocking capacitor.

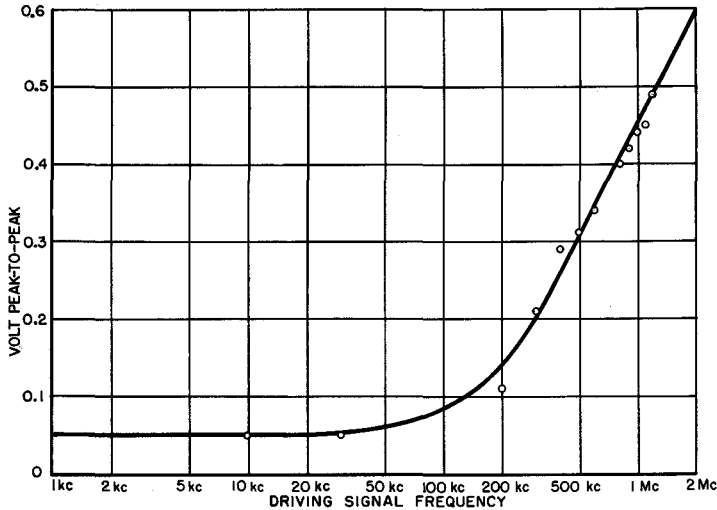

Figure 2-4. Typical sensitivity-vs-frequency characteristics.
Voltage is minimum for 1-to-1 synchronization.

2.4.3 OPERATION WITH OSCILLOSCOPE.

To observe external operation on an oscilloscope, proceed as follows:

- a. Set up the equipment to display a 1-kc square wave, as described in paragraph 2.3.4, a to k.
- b. Set the PRF switch to EXT DRIVE.
- c. Connect an adjustable audio-frequency generator to the EXTDRIVE binding posts and set the generator to produce a 1-kc signal of at least 1 volt rms.
- d. Center the ΔF control (now used as a triggering level control). The oscilloscope should display a square wave as described in paragraph 2.3.4.
- e. Decrease the frequency of the audio-frequency generator. Note that the external generator controls the prf of the Type 1217-C.
- f. Reset the audio-frequency generator to 1 kc and reduce its amplitude. When the Type 1217-C fails to trigger, adjust the ΔF control until triggering is re-established. When no further adjustment of the ΔF control will re-establish triggering, the triggering threshold has been reached (this should be at about 0.3 volt p-to-p to 1 kc). A plot of typical sensitivity is given in Figure 2-4.
- g. Reset the generator amplitude to 1 volt rms. If possible, display its output waveform and the Type 1217-C output pulse simultaneously on the oscilloscope.
- h. Adjust the ΔF control and observe the starting point of the pulse. Note that the ΔF control adjusts the phase at which the pulse is formed, and that the pulse always starts during the negative-going input transition.



2.5 PRF VS PULSE DURATION.

2.5.1 DUTY RATIO LIMITS DURATION ACCURACY.

There is no restriction on the duty ratio of the Type 1217-C. (Duty ratio is the ratio of the pulse "on" time to the total time of the period established by the prf setting; duty ratio, in percent = prf X duration X 100.) Therefore, the PULSE DURATION controls may be mistakenly set for a duration longer than the total period (period is the reciprocal of prf). The instrument cannot be damaged by such settings, but the user may be confused by the resulting oscilloscope display. Refer to Table 2-1 for duration accuracy versus duty ratio specifications.

TABLE 2-1
DURATION ACCURACY VS DUTY RATIO

<i>Duty Ratio</i>	<i>Accuracy</i>
0 to 20%	±2% of full scale with DURATION dial at 1 to 4. ±5% of reading with DURATION dial at 5 to 10. ±35 nsec with durations of 0.1 to 0.7 μsec
20 to 50%	±10% of reading.
Over 50%	Inaccurate.

2.5.2 DURATION LESS THAN 50% OF PERIOD.

The accuracy of the DURATION control settings is preserved if the duty ratio is 50% or less (pulse duration is 50% or less of total time of period). Table 2-2 lists the 50%-of-period figures for each PRF control setting.

TABLE 2-2
50% - OF - PERIOD FIGURES

<i>PRF Control Setting</i> <i>(Δ F control fully clockwise)</i>	<i>50% of Period (Durations inaccurate for DURATION control settings longer than those listed)</i>
10 cps	50 msec
30 cps	17 msec
100 cps	5 msec
300 cps	1.7 msec
1 kc	500 μsec
3 kc	170 μsec
10 kc	50 μsec
30 kc	17 μsec
100 kc	5 μsec
300 kc	1.7 μsec
1.2 Mc	0.42 μsec



2.5.3 DURATION GREATER THAN 50% OF PERIOD.

When the pulse occupies more than 50 percent of the total period, the dial reading of duration is erroneous. This effect is due to insufficient recovery time for the pulse-forming circuits but can be circumvented by reversal of the OUTPUT PULSE polarity.

For example: A 1-kc, 600 μ sec positive pulse is desired. From Table 2-2 it can be seen that 600 μ sec exceeds the 500 μ sec maximum duration given for a PRF control setting of 1 kc (actual duty ratio = $10^3 \times 6 \times 10^{-4} \times 10^2 = 60\%$). But, from Figure 2-5, it also can be seen that a positive duration of 600 μ sec can be obtained if connection is made to the -OUTPUT PULSE binding post rather than to the + OUTPUT PULSE binding post, and if the DURATION controls are set to 400 μ sec (total period minus 600 μ sec). The duty ratio for a 1-kc, 400- μ sec pulse is 40% therefore the DURATION control accuracy is preserved.

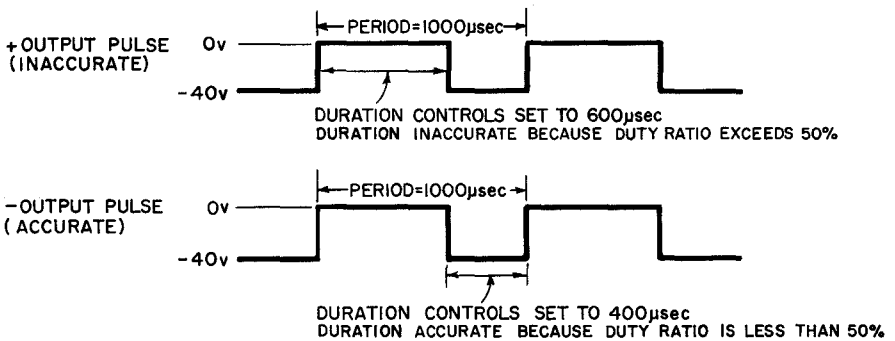

Figure 2-5. Circumvention of 50% duty-ratio limitation at 1 kc by reversal of OUTPUT PULSE polarity.

2.5.4 DURATION EQUAL TO PERIOD.

When the DURATION controls call for a pulse exactly equal to the pulse period, the instrument fails completely, and both duration and prf are indeterminate.

2.5.5 DURATION GREATER THAN PERIOD.

When the duration is set longer than the pulse period, the pulse timing circuits will "count down", producing one pulse for each 2,3,4, ...n input periods. In general, the pulse duration will not be precisely controllable due to lack of recovery time. However, such frequency division may be useful in some experiments and it should be remembered that the Type 1217-C can be used as a frequency divider of arbitrary scale by such operation.



2.6 PRECAUTIONS FOR VERY LONG OR VERY SHORT PULSES.

2.6.1 GENERAL.

When pulses of very long or very short duration are to be produced and observed, special attention must be given to the equipment setup and interconnections. Bandwidth considerations are fundamental and oscilloscopes with the desired frequency response must be chosen as indicators.

2.6.2 LONG PULSES—LOW-FREQUENCY RESPONSE.

An oscilloscope with a frequency response to dc is necessary to observe very long pulses. The low-frequency cutoff of most oscilloscopes that do not have dc amplifiers is about 5 or 10 cps, and these oscilloscopes will exhibit "ramp-off" effects with pulse durations over 10 milliseconds. (Ramp-off is the slope on the flat top and bottom.) The oscilloscope low-frequency response can be extended 10 times by use of a 10-megohm probe. Almost any indicator has adequate high-frequency response for long-duration pulses because the "flats" are usually of more interest than are the rapid rise and fall voltage transitions. The Type 1217-C uses a direct-coupled output system and will not cause ramp-off at any duration.

2.6.3 SHORT PULSES—HIGH-FREQUENCY RESPONSE.

Faithful reproduction of very short pulses or of the rapidly changing voltage of the leading or trailing edge of such a pulse requires wide-bandwidth amplifier and indicator systems. For example, when a pulse with a rise time of 0.05 μsec is displayed on an oscilloscope whose amplifier has a rise time of 0.05 μsec , the indicated rise time will be 0.07 μsec . For a system with n individual components of specified rise time, the equation for over-all rise time¹ is

$$T_r = \sqrt{T_1^2 + T_2^2 + \dots T_r^2} \quad (1)$$

The rise time of an amplifier system, T_r , is related to the 3-db bandwidth, B , by the equation (2)², where the factor of 0.35 should be used if the overshoot is less than 10 percent.

$$T_r = \frac{0.35 \text{ to } 0.45}{B} \quad (2)$$

With very short pulses, it is necessary to take care in the wiring of system components. Short, direct wires should be used for both signal and ground paths if open wiring is used, and coaxial cables should be terminated properly. A common sign of an improperly connected ground or of an inductive loop in the wiring is the presence of high-frequency ringing (damped oscillation) on the pulse transitions.

¹Valley, G. E., and Wallman, Henry, *Vacuum Tube Amplifiers*, Radiation Laboratory Series, Vol. 18, McGraw-Hill, 1948, p. 77.

²Ibid, p. 80



2.7 RISE AND FALL TIMES.

The Type 1217-C has very short rise and fall times (typically 8 nsec) of output current into the internal 1-kilohm loads and their associated stray capacitances. The internal stray capacitances are about 30 pf, which results in open-circuit rise and fall times of about 70 nsec across the internal 1-kilohm load. The rise and fall times increase linearly with external capacitance and decrease linearly with external resistance—the final transition time is about 2.2 RC. The intrinsic rise time can therefore be observed only if a resistance of 100 ohms or less is connected across the output binding posts. With an open-circuit connection, the Type 1217-C output circuit is capacitance-limited, the voltage transition varies exponentially with time, and no overshoot is possible. Because of this important feature, the Type 1217-C can be used to check almost any amplifier system for overshoot—including any oscilloscope whose input impedance is over 1 kilohm.

For further information on rise and fall times, refer to paragraph 2.8, below.

2.8 EXTERNAL LOAD CONSIDERATIONS.

The output circuits of the pulse generator are as stable as possible for an instrument of such simplicity. Some important points to remember are:

- (1) The output tubes act as current sources that produce 40-ma pulses into a parallel combination of the AMPLITUDE control potentiometer and whatever external load is connected to the instrument.
- (2) The pulses are direct-coupled to the OUTPUT PULSE binding posts and therefore contain a negative dc component of 40 ma.
- (3) In order to produce the cleanest possible pulses at low levels, the output potentiometers are used as potentiometers rather than as rheostats, so that the output tubes always produce their pulses into a full 1000-ohm load.

Figure 2-6 shows an equivalent circuit for the Type 1217-C output system as it appears when feeding a high external load impedance (e.g., a 12-pf, 10-megohm oscilloscope probe). The pulses from this circuit will be capacitance-limited by the 42-nsec RC time constant, and a rise time of 80 nsec results (Figure 2-7). As the AMPLITUDE control setting is reduced, load capacitance is essentially removed and finally, at very low output impedances, the rise time is limited only by the stray capacitance inherent in the instrument; in this instance the rise time is about 60 nsec. The appearance of a brief pulse at output settings of 0.4 volt and 4 volts is shown in Figures 2-7A and B.

Two important features should be noted from the above: (1) the rise time can be controlled by the addition of fixed external capacitance according to the equation

$$T_r \text{ (nsec)} = 2.2 (30 \text{ pf} + C_{\text{ext}}) \quad (3)$$

Figure 2-6. Equivalent circuit for Type 1217-C output system feeding high load impedance.

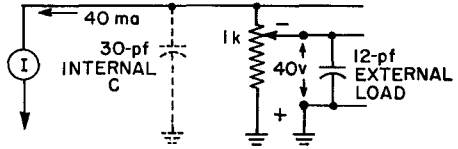

and (2) the ultimate rise time can be realized only by use of maximum AMPLITUDE control setting with a low-impedance external load. The circuit for such a connection is shown in Figure 2-8. Here the time constant of the output circuit is about 1.5 nsec, and the fast rise and fall of the current pulse can be observed. In this connection, the negative transition will typically be less than 18 nsec and the positive transitions less than 10 nsec. See Figure 2-9 for the typical appearance of waveforms under terminated conditions.

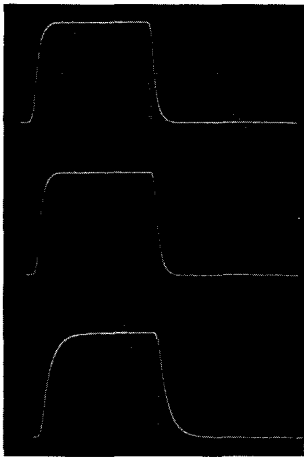

A
0.4 volt, peak-to-peak,
into 10 ohms;
0.1 μ sec/cm

B
4 volts, peak-to-peak,
into 100 ohms;
0.1 μ sec/cm

C
40 volts, peak-to-peak,
into 1 kilohm;
0.1 μ sec/cm

Figure 2-7. Pulses from circuit of Figure 2-6.

2.9 OUTPUT DC COMPONENT - DC TRANSLATION.

In certain applications it may be desirable to remove or to change the dc component of the main output pulse. There are two methods of doing this: the simplest is to add an external coupling capacitor large enough to prevent ramp-off for the desired pulse duration. Where the pulses are very long or circuit impedances are low, it may be desirable to translate the pulse dc component by use of an external power supply connected to the OUTPUT PULSE binding posts through a resistor so that it approximates a current source. Such a connection is shown in Figure 2-10, where the output impedance of the pulse generator is reduced to 800 ohms and a 33-volt pulse is produced.

Figure 2-8. Equivalent circuit for achieving ultimate rise time.

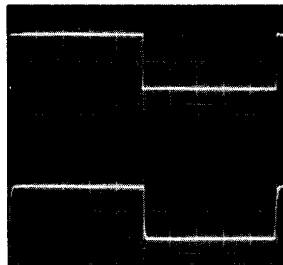
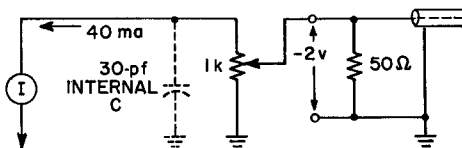

A
2-volt, 5- μ sec pulse;
50-ohm termination.

B
As in (A), but with open-
circuit termination, 40-
volt pulse.

Figure 2-9. Typical waveforms under terminated conditions.

Figure 2-10. Connection for translating pulse dc component by means of external power supply.

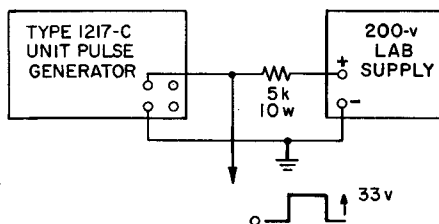

A precaution when the instrument is used under conditions of varying output impedance: In some unusual applications where dc translation is used as described above or where an external rheostat is used to adjust pulse amplitude and output impedance, the frequency of the prf oscillator will change slightly with variations in the load current. If this effect is annoying (1) change to external operation or (2) supply power to the pulse generator from two power supplies rather than from one ungrounded 300-volt supply. Connect a regulated +150-volt supply (such as a Type 1205 Adjustable Regulated Power Supply) to pin 15 of the power input connector and a regulated -150-volt supply to pin 16. Connect the commons of the two supplies to chassis ground of the Type 1217-C.

2.10 LOCKING ON HIGH-FREQUENCY SIGNALS.

2.10.1 FREQUENCY DIVIDER ACTION.

If an external signal is applied to the EXTDRIVE binding posts and the PRF switch is set to one of the numbered positions, the internal oscillator of the Type 1217-C will lock on the external signal. For instance, if a 50-kc



signal is applied at the EXT DRIVE terminals and the PRF switch is set to 10 kc (with the ΔF control fully clockwise), the main pulse of the Type 1217-C will be at 10 kc, locked to the external 50-kc signal. In other words, the pulse generator is operating as a 5-to-1 frequency divider and supplies one output pulse for each fifth input pulse. The pulse generator can be phase-locked in this manner to frequencies well above the maximum prf of the internal oscillator.

2.10.2 OBSERVATION WITH OSCILLOSCOPE.

To observe the above action, connect an oscilloscope and an audio-frequency generator to the Type 1217-C as described in paragraph 2.4.3. If possible, observe the waveform of the external generator on the oscilloscope, together with the Type 1217-C output. Then proceed as follows:

- a. Set the PRF switch to 1 kc.
- b. Set the ΔF control fully clockwise.
- c. Set the external generator to 1 kc.
- d. Set the output amplitude of the external generator to minimum and then increase it until the Type 1217-C locks.
- e. Set the frequency of the external generator to 2 kc, 3 kc, 4 kc, etc., and each time advance the signal amplitude to lock the pulse generator. In this way the pulse generator can be locked at very high ratios.

2.11 COUNT-DOWN OPERATION.

When the duration is set longer than the pulse period, the pulse timing circuits will "count down," producing one pulse for each 2,3,4 ...n input periods. In general, the pulse duration will not be precisely controllable, owing to lack of recovery time. However, such frequency division may be useful in some experiments and it should be remembered that the Type 1217-C can be used as a frequency divider of arbitrary scale by such operation.

2.12 SINGLE-PULSE OPERATION.

2.12.1 METHODS.

There are three ways by which one can produce a single pulse:

1. By rotating the ΔF control with the PRF switch set to EXT DRIVE.
2. By touching the EXT DRIVE binding post.
3. By using the Type 1217-P2 Single-Pulse Trigger.

The following three paragraphs explain each method in detail.

2.12.2 ROTATION OF ΔF CONTROL.

Set the PRF switch to EXT DRIVE and rotate the ΔF control about 20 or 30 degrees clockwise from its center position and then reverse the di-



rection of rotation. An output pulse will be produced as the ΔF control is moved counterclockwise past the center position. Very little rotation is necessary to reset and to start the input circuits. Be careful not to touch the EXT DRIVE binding post because a pulse burst may be produced by the injected hum.

2.12.3 TOUCHING EXT DRIVE BINDING POST.

Set the PRF switch to EXT DRIVE and set the ΔF control near the center of its range. A single pulse will be produced when the EXT DRIVE binding post is touched. This method is useful only for very long pulses because the driving signal is a burst of noise or hum.

2.12.4 TYPE 1217-P2 SINGLE-PULSE TRIGGER.

The most convenient way to produce single pulses is to use a push-button actuating circuit such as the Type 1217-P2 Single-Pulse Trigger, shown pictorially in Figure 1-2 and schematically in Figure 2-11. To use it, set the PRF switch to EXT DRIVE and experiment with the ΔF control while pushing the button of the Type 1217-P2 to obtain proper triggering.

To produce a main pulse when the switch opens, connect the negative banana plug of the Type 1217-P2 (arrowhead terminal in Figure 2-11) to the EXT DRIVE binding post of the Type 1217-C.

To produce a main pulse when the switch closes, reverse the double banana plug of the Type 1217-P2 so the positive banana plug (ground symbol in Figure 2-11) is connected to the EXT DRIVE binding post of the Type 1217-C.

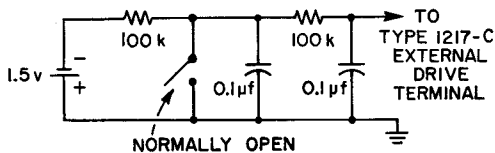

Figure 2-11.

Schematic diagram of the Type 1217-P2 Single-Pulse Trigger.

2.13 USE AS A DELAY GENERATOR.

The delayed sync pulse from the Type 1217-C can be used to operate the input circuits of a second Type 1217-C with a minimum of adjustment. The delayed pulse consists of a negative-going transition of about 5 volts and 100-nsec duration, followed immediately by a positive transition of about 5 volts and 150-nsec duration. The initial negative-going transition will trigger the input circuits and start the main pulse of a following Type 1217-C. The positive-going transition will then reset the input circuits of the second Type 1217-C to prepare it for the next delayed pulse. Figure 2-12 shows connections and timing waveforms of such a system.

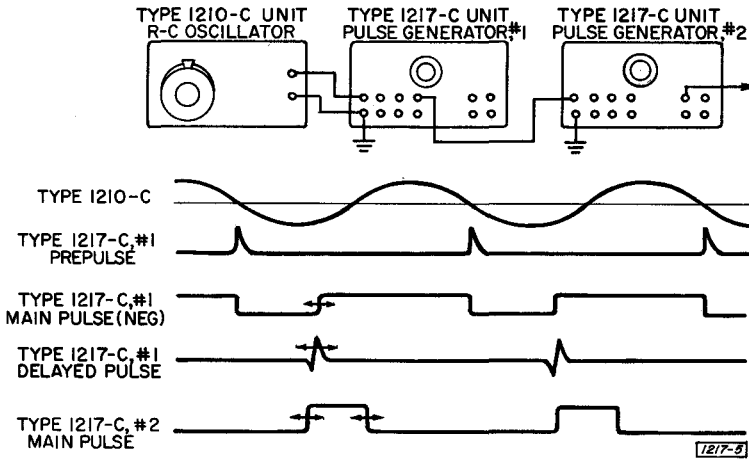

Figure 2-12. Connection of two Type 1217-C's as a delay generator.

2.14 USE FOR COMPLEX WAVEFORMS.

Since the output circuit of the Type 1217-C is essentially a current source feeding a resistive load, the outputs of two or more pulse generators can be directly paralleled to produce complex additive waveforms. The output impedance of n pulse generators so paralleled is $1000/n$ ohms and the peak voltage is still 40 volts. A complex waveform and the system to produce it are shown in Figure 2-13.

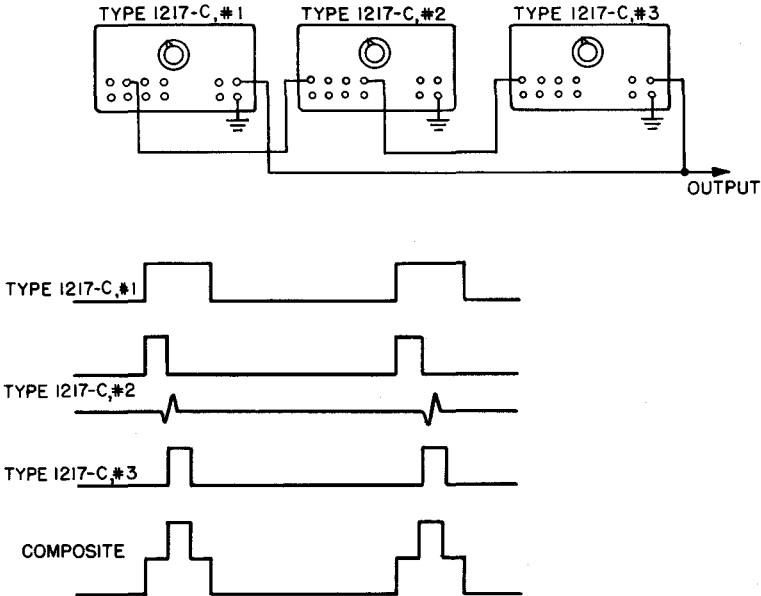

Figure 2-13. System for producing the complex waveform shown.

SECTION 3

PRINCIPLES OF OPERATION

3.1 GENERAL.

The Type 1217-C is composed of two basic sections: (1) the input and prf oscillator circuit and (2) the output pulse circuit.

Externally or internally generated positive spikes from the input and prf oscillator circuit trigger the output pulse circuit. The output pulse circuit, in turn, produces positive and negative pulses that appear at the OUTPUT PULSE binding posts. A detailed analysis of each circuit is contained in the following paragraphs.

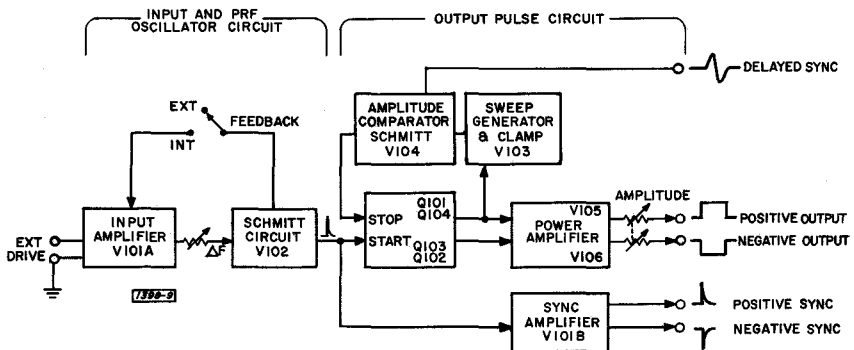

Figure 3-1. Block diagram of the Type 1217-C Unit Pulse Generator.

3.2 INPUT AND PRF OSCILLATOR CIRCUIT – EXTERNAL OPERATION.

3.2.1 GENERAL.

Let us first consider the circuit as an aperiodic input circuit, i.e., with the PRF switch set to EXT DRIVE, as shown in Figure 3-2. In this mode, the circuit converts an external signal, applied to the EXT DRIVE binding posts, to a positive spike, which appears at the output, pin 6 of V102B.

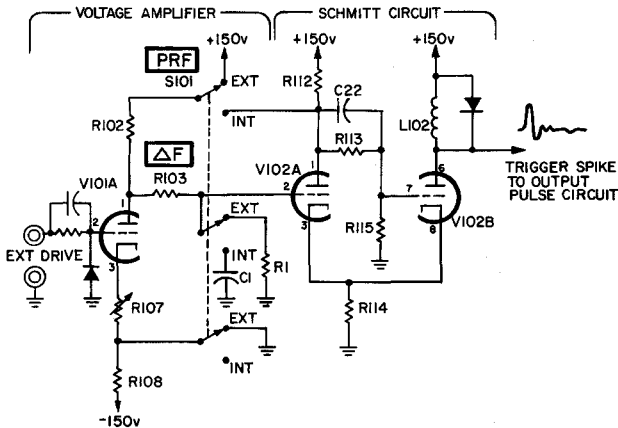

Figure 3-2. Simplified schematic diagram of the input and prf oscillator circuit.

3.2.2 SCHMITT CIRCUIT

Quiescent: V102A OFF, V102B ON

V102A and B form a Schmitt multivibrator circuit. The grid voltage of V102B is set to about +48 volts by the voltage divider R113 and R115. V102B, therefore, is on (conducting) and V102A is off (not conducting).

3.2.3 SCHMITT CIRCUIT

Switching Action

In the quiescent state, V102A is further biased off by the voltage divider R102, R103, and R1. This bias is such that the grid voltage must be increased to about +45 volts before V102A will turn on. If its grid reaches +45 volts, it begins to conduct and its plate voltage begins to drop (its plate signal is inverted with respect to its grid signal). This negative-going signal is coupled through C22 to the grid of V102B and causes V102B to start turning off. As V102B starts turning off, the common cathode voltage decreases, which also lowers the bias of V102A. As this bias lowers, V102A conducts more and more until it is conducting as heavily as its plate load resistor, R112, will allow it to. This is the normal regenerative action of any multivibrator. Upon completion of the switching action, V102A is on and V102B is off. Note that the output at pin 6 of V102B has been inductively spiked by L102.

3.2.4 VOLTAGE AMPLIFIER
Schmitt Hysteresis

In order to reverse the conductive states of V102A and V102B, the grid voltage of V102A must be lowered below the level that was necessary to cause the switching action in the first place. Thus the circuit presents a voltage hysteresis effect.

V101A and R102 operate as a voltage divider to set the grid voltage of V102A to a level near the center of this hysteresis region (exactly at the center for maximum sensitivity with a symmetrical waveform). V101A is connected as a voltage amplifier so that the hysteresis is reduced in voltage as presented to the EXT DRIVE binding posts. R107 is factory-adjusted so that the hysteresis effect referred to the EXT DRIVE terminals is symmetrical with respect to ground when the ΔF control, R103, is centered.

A single pulse can be produced (paragraph 2.12.2) by rotation of the ΔF control through its centered position. This rotation simply sets and resets the Schmitt trigger.

3.3 INPUT AND PRF OSCILLATOR CIRCUIT – INTERNAL OPERATION.

3.3.1 GENERAL.

In Figure 3-2, the PRF switch is shown in the EXT DRIVE position. When this switch is set to any of the other positions, the voltage amplifier and Schmitt circuits are converted to a prf oscillator.

3.3.2 OSCILLATOR ACTION.

The PRF switch, S101, converts the input amplifier to a current source that translates the plate swing of V102B so that it is symmetrical around its own grid voltage. The switch ungrounds the junction of R107 and R108 and switches R102 from the plate supply voltage to the plate of V102A. The ΔF control (R103) and R102 form the resistance part of the frequency determining network and the PRF switch forms the capacitance part by adding capacitance from the grid of V102A to ground. The mechanism of oscillation is shown in Figure 3-3. Suppose that V102A is off; its plate voltage is high and C1 charges through R103 and R102 until V102A turns on. When V102A

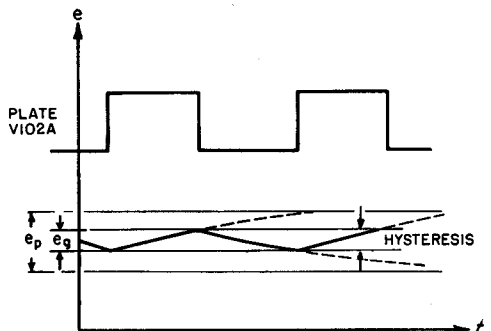

Figure 3-3. Diagram showing operation of internal oscillator.

turns on, its plate voltage falls and C1 begins to discharge. C1 continues to discharge until V102A again turns off. The Schmitt circuit thus oscillates with V102A's grid voltage "trapped" within the hysteresis region. The prf is changed by adjustment of capacitance with the PRF switch and resistance with the ΔF control.

3.3.3 OSCILLATOR STABILITY.

The output frequency of this oscillator is quite stable. Parameters important in controlling frequency are R, C, and the magnitude of the hysteresis is established by the Schmitt circuit design, where both sections of V102 operate far from zero bias so that R114 provides current feedback, and stabilizes the circuit against the effects of changing tube characteristics. Typical warmup and drift characteristics are shown in Figure 3-4.

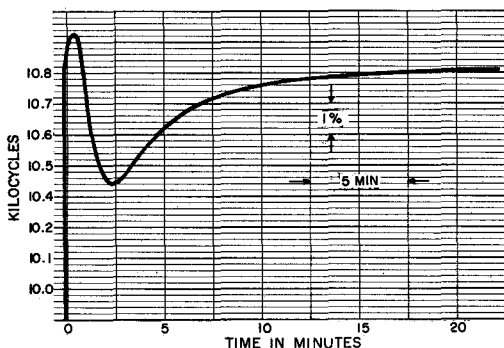

Figure 3-4a. Typical warmup characteristics of prf oscillator.

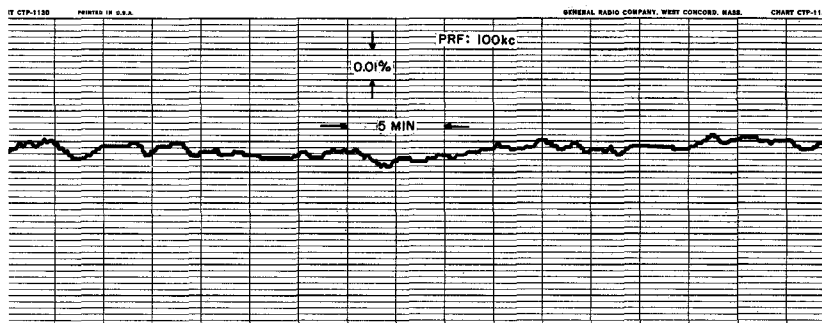

Figure 3-4b. Typical drift characteristics of prf oscillator.

3.4 OUTPUT PULSE CIRCUIT.

3.4.1 GENERAL.

The output pulse circuit produces a positive and negative output pulse, simultaneously, for each positive spike it receives from the prf oscillator.

3.4.2 START AND STOP SIGNAL PATHS.

The output pulse circuit requires a positive spike to start its action, but once started, will turn itself off. Therefore, there are two signal paths in the circuit; one to start the action and one to stop it. Both paths are shown in Figure 3-5.

3.4.3 POWER AMPLIFIERS, AMPLITUDE CONTROL.

The output power amplifiers are V105 and V106. The plate-load resistor of each amplifier is a 1-kilohm potentiometer with the center-arm connected to the respective OUTPUT PULSE binding post. Both potentiometers are ganged together so that a common front panel AMPLITUDE control sets the output amplitude and impedance of both amplifiers.

3.4.4 + OUTPUT AMPLIFIER

Quiescent: V105 ON

With the AMPLITUDE control set for the maximum output, the positive output pulse starts from -40 volts and rises to 0 volts. Therefore, in the quiescent state (before the trigger spike from the input and prf oscillator circuit is applied) V105 is on (conducting) and about 40 ma flows through R130, causing its center-arm to rest at about -40 volts.

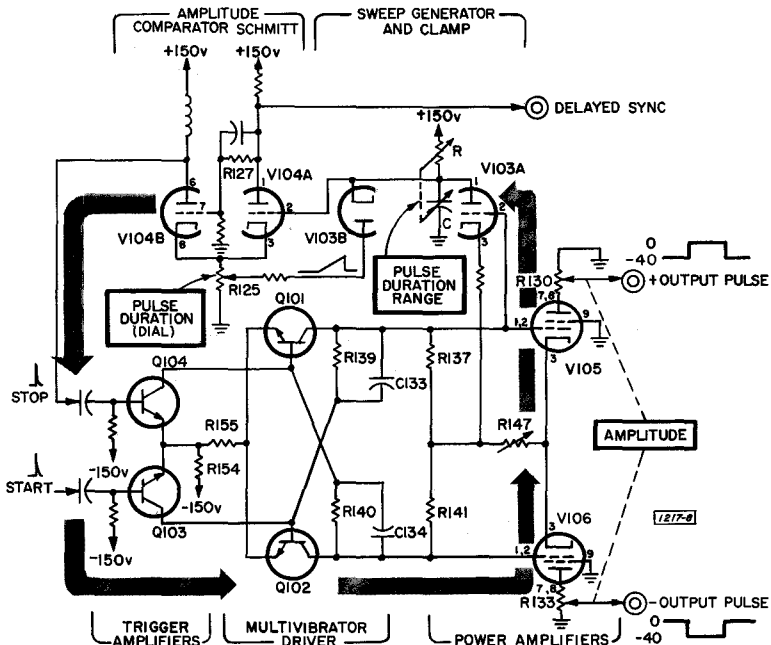

Figure 3-5. Simplified schematic diagram of the output pulse circuit.



3.4.5 - OUTPUT AMPLIFIER

Quiescent: V106 OFF

The negative output pulse starts from 0 volts and falls to -40 volts. Therefore, in the quiescent state, V106 is off (not conducting), no current flows through R133, and its center-arm rests at ground potential (0 volts).

3.4.6 MULTIVIBRATOR DRIVER, OUTPUT AMPLIFIER BIAS.

Quiescent: Q101 OFF, Q102 ON

The plate voltages of the output amplifiers are controlled by their grid voltages, which, in turn, are controlled by the multivibrator driver, which consists of two npn transistors, Q101 and Q102.

As noted before, V105 is on in the quiescent state which means its grid bias must be low enough to allow conduction. The bias of V105 is determined by the current that flows through R147 and R137. Current always flows through R147 because it is the common cathode resistor of V105 and V106 and one or the other of these tubes is always on. The value of this current is about 50 ma, which results in about a 10-volt bias; not sufficient, in itself, to turn off either V105 or V106.

But if current were to flow through R137, the voltage drop across R137 and R147 (V105 bias) would be sufficiently large to turn off V105. Since V105 is on, not off, its bias must be due only to the current through R147, and no current must be flowing through R137.

R137 is part of the collector load for Q101. Since there is no current through R137, Q101 must be off. When Q101 is off, Q102 is on because the two transistors form a bistable multivibrator. With Q102 on, current flows through R141 and this current, in conjunction with the current through R147, is sufficient to bias V106 off – the quiescent condition described above in paragraph 3.4.5.

3.4.7 TRIGGER AMPLIFIERS

Start Signal Action

Q103 and Q104 are the trigger amplifiers. Both are biased off. Since both are npn transistors, a positive spike applied to their bases will turn them on for the duration of the spike. When a start signal (positive spike) arrives from the input and prf circuit, it is applied to the base of Q103. Q103 conducts and produces a negative spike at its collector.

3.4.8 MULTIVIBRATOR DRIVER SWITCHING

Start Signal Action

The negative spike at the collector of Q103 is coupled to the base of Q102 and causes Q102 to start to turn off. Q102 is one half of a multivibrator that consists of Q102 and Q101; as Q102 starts to turn off, Q101 starts to turn on. This is the normal regenerative action of any multivibrator and the discussion that follows describes the switching action and the regenerative paths of Q101 and Q102.

The negative spike at the base of Q102 appears as a positive spike at the collector of Q102. This positive spike is coupled through C134 to the base



of Q101 and causes Q101 to start to turn on. The positive spike at the base of Q101 appears as a negative spike at the collector. This negative spike is coupled through C133 and R139 back to the base of Q102, aids the negative spike already present from the collector of Q103, and thus completes the regenerative loop. Upon completion of the switching action, Q101 is on and Q102 is off.

3.4.9 OUTPUT AMPLIFIERS

Start Signal Action

Since the multivibrator driver has reversed its state, the output amplifiers have also reversed their states. V105 is now off and the + OUTPUT PULSE voltage is 0 volts instead of -40 volts and V106 is now on and the - OUTPUT PULSE voltage is -40 volts instead of 0 volts. All that remains to convert these dc-voltage steps to pulses is to return the circuits to their quiescent levels.

3.4.10 SWEEP GENERATOR AND CLAMP, DURATION CONTROL

Quiescent: V103A ON, V103B ON

The stop signal returns the circuits to their quiescent levels. The length of time it takes the circuits to return is the length of the output pulse (pulse duration); therefore the PULSE DURATION controls are located in the stop signal path.

The duration is actually controlled by a sweep generator whose sweep rate can be adjusted by the DURATION controls. Before the arrival of a start spike, all circuits are in their quiescent states. V105 is on because of its low grid bias. The grid bias of V105 is also the grid bias of V103A, therefore V103A is also on in the quiescent state.

The plate load of V103A is very large compared with the cathode load. Since the cathode load is returned to -150 volts, the voltage at the plate of V103A is negative when it is on. This negative voltage is applied to the cathode of the diode, V103B, and since the plate of V103B is connected to a potential that is positive with respect to its cathode, V103B is also on.

3.4.11 AMPLITUDE COMPARATOR SCHMITT

Quiescent: V104A OFF, V104B ON

The amplitude comparator Schmitt multivibrator consists of V104A and V104B. V104B is on in the quiescent state because of the divider, R127 and R129, that is connected to its grid. When V104B is on, V104A is off, because the two tubes form multivibrator and also because the grid of V104A is tied to the negative potential at the plate of V103A.

The bias of both V104A and V104B is also set by R125, the PULSE DURATION dial. In the quiescent state, V103A sets the grid of V104A sufficiently negative so that R125 has no effect on whether or not either tube will conduct.

3.4.12 SWEEP GENERATOR AND CLAMP

Stop Signal Action

When V105 reverts from its quiescent state, it turns off. V103A also turns off because both tubes share a common bias. When V103A turns off,



capacitor C begins to charge to +150 volts. As it charges, it draws current through the plate load resistor, R, of V103A and thus keeps the plate of V103A from returning immediately to +150 volts.

Therefore, the voltage at the plate of V103A goes positive at a rate determined by the values of C and R. After a period of time, this voltage will become positive enough to overcome the bias of V104A that was set by the DURATION potentiometer, R125.

When the bias is overcome, V104A turns on and, due to regenerative action, V104B turns off. When V104B turns off, its plate goes more positive, and this positive spike is applied to the stop trigger amplifier.

3.4.13 STOP TRIGGER AMPLIFIER

Stop Signal Action

The stop trigger amplifier behaves in the same fashion as the start trigger amplifier when it receives a positive spike, i.e., it reverses the state of the multivibrator, which, in turn, reverses the state of the output amplifiers. Thus V105 is turned back on, V106 is turned off, all circuits have returned to their quiescent levels, and the output pulse is terminated.

SECTION 4

SERVICE AND MAINTENANCE

4.1 WARRANTY.

We warrant that each new instrument sold by us is free from defects in material and workmanship, and that, properly used, it will perform in full accordance with applicable specifications for a period of two years after original shipment. Any instrument or component that is found within the two-year period not to meet these standards after examination by our factory, sales engineering office, or authorized repair agency personnel, will be repaired or, at our option, replaced without charge, except for tubes or batteries that have given normal service.

4.2 SERVICE.

The two-year warranty stated above attests the quality of materials and workmanship in our products. When difficulties do occur, our service engineers will assist in any way possible. If the difficulty cannot be eliminated by use of the following service instructions, please write or phone our Service Department (see rear cover), giving full information of the trouble and of steps taken to remedy it. Be sure to mention the service and typenumber of the instrument.

Before returning an instrument to General Radio for service, please write to our Service Department or nearest sales engineering office, requesting a Returned Material Tag. Use of this tag will insure proper handling and identification. For instruments not covered by the warranty, a purchase order should be forwarded to avoid unnecessary delay.



4.3 REMOVAL OF COVER.

To open the instrument for access to components, loosen the large fluted screw at the rear of the right-hand side of the cabinet. Then grasp the panel by the top and bottom edges with one hand, and with the other hand slide the aluminum dust cover away from the panel and off the rear.

All components are easily accessible. See Figures 4-3, 4-4, and 4-6 for location of components.

4.4 TROUBLE - SHOOTING NOTES.

4.4.1 GENERAL.

If the pulse generator is inoperative, make the following simple checks before removing the cover:

a. Check the power line voltage and frequency to make sure they are as required by the power supply.

b. Check line cord, fuses, and voltage from the power supply (B + demands are 300 volts at 60 ma).

c. See if the prepulse is present at the SYNC binding posts. If this pulse is present and the main pulse is defective, refer to paragraph 4.4.2. If the prepulse is present and there is no main pulse, refer to paragraph 4.4.3. If neither prepulse nor main pulse is present, refer to paragraph 4.4.4. If prepulse is absent and main pulse is present, refer to paragraph 4.4.7.

4.4.2 DEFECTIVE MAIN PULSE.

Overshoot. Under normal conditions, with a high impedance load, overshoot is not possible on any transition. Therefore, check the oscilloscope for overshoot first. If overshoot occurs with a low-impedance terminated system, check the system for proper grounding and make sure that all wiring is as short as possible. Note that some overshoot may be present on negative pulse transitions as shown in Figure 2.9.

Large imbalance in pulse amplitudes or slowly falling negative-going edge of positive pulse. These defects can be caused by weakening of one of the output tubes. These tubes (V105, V106) are chosen for balance at the factory; if either is defective, therefore, order a replacement set or choose a balanced pair if possible. If the output tubes are replaced, readjust R147 to produce -150 volts at pin 16 of PL101 with a 300 volt regulated power supply (refer to paragraph 4.7.2 of the calibration procedure for further details).

Output pulse occasionally fails, and starts only when RANGE switch setting is changed. There are two possible causes of this difficulty: (1) The ionization voltage of V107 has drifted sufficiently so that the automatic restarting circuit no longer functions, or (2) a tube has developed heater-to-cathode leakage. First check the voltage from pin 13 or 14 of PL101 to ground, using an electronic voltmeter of at least 100 megohms input impedance. The proper voltage is -70 ± 5 volts behind 5 megohms. If this voltage is correct, the trouble is a defective V107, and a new NE-96 should be installed. If the voltage measured is not correct, check all tubes for heater-to-cathode leakage.



Pulse duration errors. An error indication on only one setting of the RANGE switch is an indication that a time-determining component for that range has drifted or failed.

A uniform error on all ranges is an indication that the amplitude comparison circuit (V104 and associated components) is defective. For instance, a decrease in resistance of R127 would make all pulses too long at all settings of the PULSE DURATION controls, while an increase in this resistance would reverse the effect.

If the output pulse is of fixed, long duration, independent of the PULSE DURATION controls, V103B is not functioning, and a new tube should be inserted.

Another difficulty traceable to a defective V103 would be excessive duration at the high end of each range, especially at longer duration ranges. It is probable that V103 is not remaining off, and it should be replaced.

4.4.3 NO MAIN OUTPUT PULSE, SYNC PULSES PRESENT.

If no output pulses are present and V107 flashes continually, check V103 and V104 and replace if necessary.

If V107 is not flashing, measure the voltage at the + OUTPUT PULSE binding post. If it is -40 volts with respect to ground, the trouble is either a defective transistor Q102 or Q104 or failure of the start triggering circuits. Check for the presence of a 15-volt, 0.15 μ sec positive trigger pulse at pin 6 of V102. Check L103 for a short or open circuit.

4.4.4 MAIN AND SYNC PULSES BOTH ABSENT.

This indicates trouble in the input circuits. First check V101 and V102. (After replacing V101, center the ΔF control and adjust R107 for optimum sensitivity with an external signal.) If this fails to pinpoint the problem, check voltages against those given in Table 4-1.

4.4.5 INCORRECT FREQUENCIES.

If the frequency error occurs at only one setting of the PRF switch, the fault is one of the timing capacitors, C108 through C117. Replace the appropriate capacitor.

If all frequencies are in error by about the same amount with the ΔF control fully clockwise, check R102, R108, R104, and R105.

4.4.6 FAILS TO SYNC ON EXTERNAL SIGNAL.

If the instrument operates normally on internal operation but will not synchronize on external signals, check the input network. An extremely high transient voltage may have caused CR101 to short-circuit.

4.4.7 MAIN PULSES PRESENT, NO SYNC PULSES.

Check V101 and the components associated with V101B.



4.5 WAVEFORMS.

4.5.1 TEST CONDITIONS.

Figure 4-1 depicts important waveforms in the Type 1217-C. They were taken with a 10-megohm, 12-pf probe; the vertical sensitivity listed beside each oscillogram includes the 10X attenuation of the probe. Power was supplied by a Type 1201 Unit Regulated Power Supply. The Type 1217-C controls were set as follows (except where noted):

- PRF..... 100 kc
- ΔFcentered
- PULSE DURATION dial.....1
- PULSE DURATION RANGE.....0.1 to 1 μ sec
- AMPLITUDE.....1000 (fully clockwise)

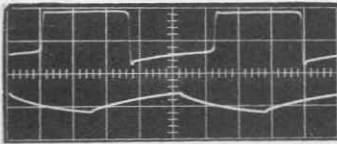

V102, pin 1, 20v/cm, 2 μ sec/cm.
V102, pin 2, 20v/cm, 2 μ sec/cm.

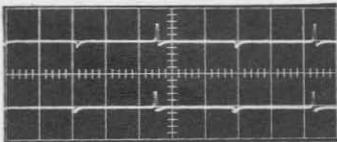

V101, pin 7, 20v/cm, 2 μ sec/cm.
V101, pin 8, 20v/cm, 2 μ sec/cm.

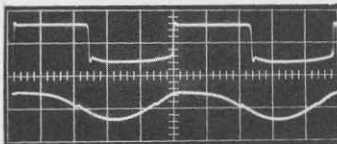

V102, pin 1, 20v/cm, 2 μ sec/cm;
1v, 100kc external drive.
V102, pin 2, 20v/cm, 2 μ sec/cm;
1v, 100 kc external drive.

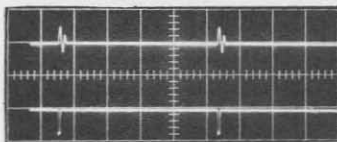

V104, pin 2, 10v/cm, 2 μ sec/cm.
V103A, pin 2, 20v/cm, 2 μ sec/cm.

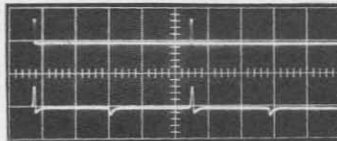

V106, pin 2, 20v/cm, 2 μ sec/cm.
V102, pin 6, 20v/cm, 2 μ sec/cm.

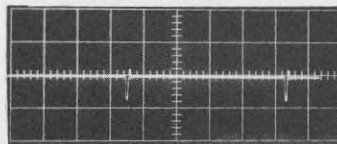

V104, pin 1, 20v/cm, 2 μ sec/cm.

Figure 4-1. Waveforms.



4.6 VOLTAGES AND RESISTANCES.

TABLE 4 - 1
VOLTAGES AND RESISTANCES

<i>Tube</i>	<i>Pin</i>	** <i>Dc Volts to Ground</i>	*** <i>Ohms to Ground</i>	<i>Transistor</i>	<i>Lead</i>	<i>Dc Volts to Supply</i>	*** <i>Ohms to Ground</i>	
V101 6DJ8	1	33	34k	Q101	E	1.5	30	
	2	-0.1	*300 to 1M	2N708	B	15	52k	
	3	0.8	52k		C	1.7	52k	
	6	135	1k	Q102	E	1.5	30	
	7	10	51k	2N708	B	1.8	52k	
	8	0	1k		C	2.3	52k	
	V102 6DJ8	1	123	3k	Q103	E	0.75	15
		2	33	85k	2N708	B	2.3	52k
3		39	3.3k		C	0	10k	
6		150	2					
7		33	67k	Q104	E	0.75	15	
8		39	3.3k	2N708	B	1.7	52k	
V103 6DJ8	1	44	68k		C	0	50k	
	2	135	52k					
	3	130	54k					
	6	44.5	5.6k					
	7	44.5	5.6k					
V104 6DJ8	1	149	1.5k					
	2	44	68k					
	3	52	5k					
	6	150	1.2					
	7	50	65k					
	8	52	5k					
V105 6CW5	1	135	52k					
	2	135	52k					
	3	135	51.5k					
	7	43	1k					
	8	43	1k					
	9	0	49k					
V106 6CW5	1	147	52k					
	2	147	52k					
	3	125	51.5k					
	7	0	1k					
	8	0	1k					
V107 NE-96	+	44	68k					
	-	-75	0					

TEST CONDITIONS

This table lists important voltages and resistances in the Type 1217-C. Power was supplied by a Type 1201-B Unit Regulated Power Supply. The Type 1217-C controls were set as follows:

PRF.....1 kc

ΔF.....centered

PULSE DURATION

dial.....1

RANGE..... 0.1 to 1 μsec

AMPLITUDE..... 1000 (fully cw)

* Depends on ohmmeter polarity and resistance range.

** All heaters elevated to -70v.

*** Power supply disconnected, all PL101 terminals grounded, all transistors removed.





4.7 CALIBRATION PROCEDURE.

4.7.1 TEST SETUP AND EQUIPMENT REQUIRED.

General. A description of the equipment required for a complete calibration of the Type 1217-C Unit Pulse Generator is given in the paragraphs that follow. The interconnections necessary are shown in Figure 4-2.

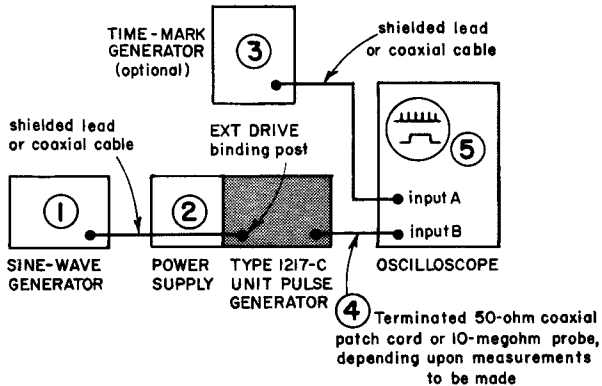

Figure 4-2. Calibration Test Setup.

(1) Sine-wave generator. Capable of 10 kc, 0.1v into 1 M Ω and 2.2 Mc, 0.5v into 1 M Ω . Accuracy $\pm 10\%$ or better. The Type 1330 Bridge Oscillator or the Type 1001 Standard Signal Generator may be used.

(2) Power supply. Capable of 6.3v ac at 3a and 300v dc at 60 ma. The Type 1201 Unit Regulated Power Supply or two Type 1205 Adjustable Regulated Power Supplies may be used. (Refer to paragraph 2.1.2 for additional power supply details.)

(3) Time-mark generator. Capable of 100-msec to 0.1 μ sec marks in 5 decade ranges. Accuracy $\pm 0.1\%$ or better. The use of a time-mark generator is optional. When it is used, time-measurement accuracy is dependent upon the accuracy of the time-mark generator (typically 0.001%) rather than upon the accuracy of the oscilloscope time-base (typically 3%).

(4) Terminated 50-ohm coaxial patch cord. A coaxial cable with a double banana plug on one end, a coaxial fitting on the other end, and a 50-ohm noninductive resistor on the coaxial fitting end. An assembly that consists of a Type 874-R34 Coaxial Patch Cord, a Type 874-W50 50-Ohm Termination, and an adaptor to fit the 50-ohm termination to the oscilloscope may be used. A Type 874-QUP Adaptor fits uhf connectors and a Type 874-QBPA Adaptor fits BNC connectors.

(5) Oscilloscope. Capable of measuring 10-nsec rise times and durations of 1.05 sec to 75 nsec. Accuracy $\pm 1\%$ or better. Must have sweep delaying provision if time jitter is to be measured (paragraph 4.7.4).

4.7.2 PRF ACCURACY.

Setup. Connect the -OUTPUT PULSE binding posts to the oscilloscope via a terminated 50-ohm coaxial patch cord. Set the Type 1217-C controls as follows:

- ΔF..... HIGH (fully clockwise)
- PULSE DURATION dial.....1
- PULSE DURATION RANGE.....0.1 to 1 μsec
- AMPLITUDE.....1000 (fully clockwise)

PRF switch accuracy. Check or adjust the pulse repetition frequency as outlined in Table 4-2. Note that frequency is measured in terms of period length (1/prf).

TABLE 4-2
PRF ACCURACY

<i>PRF Switch Setting</i>	 <i>Period 1/prf</i> <i>±5% Tolerance</i>
100 cps	Adjust R147 for minimum period then adjust R158 for period of 10 msec.
10 cps	95 to 105 msec
30 cps	31.7 to 35 msec
300 cps	3.17 to 3.5 msec
1 kc	950 to 1050 μsec
3 kc	315 to 350 μsec
10 kc	95 to 105 μsec
30 kc	31.7 to 35 μsec
100 kc	9.5 to 10.5 μsec
300 kc	Adjust C117 for period of 3.33 μsec. Vary ΔF control over full range; period must change smoothly and must be greater than 10 μsec when ΔF control is set fully counterclockwise.
1.2 Mc	Adjust C140 for period of 850 μsec.



4.7.3 PULSE DURATION ACCURACY.

Setup. Connect the -OUTPUT PULSE binding posts to the oscilloscope via a terminated 50-ohm coaxial patch cord. Set the Type 1217-C controls as follows:

ΔFHIGH (fully clockwise)
AMPLITUDE.....1000 (fully clockwise)

PULSE DURATION dial accuracy. In each of the following checks, set the PULSE DURATION dial for the indicated duration as measured on the oscilloscope and note the PULSE DURATION dial reading:



<i>PULSE DURATION RANGE Setting</i>	<i>Maximum PRF</i>	<i>DURATION Set PULSE DURATION dial for measured duration of:</i>
10 to 100 μ sec	3 kc	50 μ sec
100 μ sec to 1 msec	300 cps	500 μ sec
1 to 10 μ sec	30 cps	5 msec
10 to 100 msec	10 cps	50 msec

The difference between the lowest and highest PULSE DURATION dial readings is the error span. Mechanically position the PULSE DURATION dial with respect to its associated potentiometer so that a reading of 5 lies on the center of the error span.

For example: If the lowest dial reading was 5.8 and occurred on the 10 to 100 msec RANGE and the highest dial reading was 6.6 and occurred on the 1 to 10 msec RANGE, the error span is $6.6 - 5.8 = 0.8$.

Set the RANGE switch to 10 to 100 msec (the range where the lowest dial reading was noted) and set the PULSE DURATION dial for a measured duration of 50 msec. Loosen the hub set-screw (behind the PULSE DURATION potentiometer) and position the dial for a reading of $5 - 0.4 = 4.6$. Be careful not to disturb the setting of the potentiometer itself; the measured duration must remain 50 msec. Tighten the setscrew. A dial reading of 5 now lies in the center of the error span (center of error span = error span $\div 2$ or $0.8 \div 2 = 0.4$).

To be sure a PULSE DURATION dial reading of 5 lies in the center of the error span, set the RANGE switch to 1 to 10 msec (the range where the highest dial reading was noted) and set the PULSE DURATION dial for a measured duration of 5 msec. If the dial has been positioned correctly it will read $5 + 0.4 = 5.4$.

PULSE DURATION RANGE accuracy. Check or adjust the PULSE DURATION RANGE accuracy as outlined in Table 4-3.



**TABLE 4-3
PULSE DURATION RANGE ACCURACY**

<i>PULSE DURATION RANGE</i>	<i>Dial</i>	<i>Maximum PRF</i>	<i>Duration Limits</i>
100 msec to 1 sec	1	10 cps	95 to 105 msec ($\pm 2\%$ of full scale)
10 to 100 msec	1	30 cps	9.5 to 10.5 msec ($\pm 2\%$ of full scale)
1 to 10 msec	1	300 cps	0.95 to 1.05 msec ($\pm 2\%$ of full scale)
100 μ sec to 1 msec	1	3 kc	95 to 105 μ sec ($\pm 2\%$ of full scale)
10 to 100 μ sec	1	30 kc	9.5 to 10.5 μ sec ($\pm 2\%$ of full scale)
1 to 10 μ sec	1	300 kc	0.9 to 1.05 μ sec ($\pm 2\%$ of full scale)
0.1 to 1 μ sec	1	1.2 Mc	65 to 135 nsec (± 35 nsec)
100 msec to 1 sec	5	10 cps	475 to 525 msec ($\pm 5\%$ of reading)
10 to 100 msec	5	10 cps	47.5 to 52.5 msec ($\pm 5\%$ of reading)
1 to 10 msec	5	30 cps	4.75 to 5.25 msec ($\pm 5\%$ of reading)
100 μ sec to 1 msec	5	300 cps	475 to 525 μ sec ($\pm 5\%$ of reading)
10 to 100 μ sec	5	3 kc	47.5 to 52.5 μ sec ($\pm 5\%$ of reading)
1 to 10 μ sec	5	30 kc	4.75 to 5.25 μ sec ($\pm 5\%$ of reading)
0.1 to 1 μ sec	5	300 kc	465 to 535 nsec (± 35 nsec)
100 msec to 1 sec	10	10 cps	0.95 to 1.05 sec ($\pm 5\%$ of reading)
10 to 100 msec	10	10 cps	95 to 105 msec ($\pm 5\%$ of reading)
1 to 10 msec	10	30 cps	9.5 to 10.5 msec ($\pm 5\%$ of reading)
100 μ sec to 1 msec	10	300 cps	0.95 to 1.05 msec ($\pm 5\%$ of reading)
10 to 100 μ sec	10	3 kc	95 to 105 μ sec ($\pm 5\%$ of reading)
1 to 10 μ sec	10	30 kc	9.5 to 10.5 μ sec ($\pm 5\%$ of reading)
0.1 to 1 μ sec	10	300 kc	Adjust C141 for duration of 1 μ sec

4.7.4 OUTPUT PULSE CHARACTERISTICS.

Setup. The characteristics and specifications for both the + and the - OUTPUT PULSE waveforms are the same, except for polarity. Connect the appropriate OUTPUT PULSE binding posts to the oscilloscope via a terminated 50-ohm cable. Set the Type 1217-C controls as follows:

- ΔFHIGH (fully clockwise)
- PRF.....1.2 MC
- PULSE DURATION dial.....5
- PULSE DURATION RANGE.....0.1 to 1 μ sec
- AMPLITUDE.....1000 (fully clockwise)

Amplitude. Equal to or greater than 2 volts, peak-to-peak.





Rise time. 10 nsec or faster as measured between the 10 and 90% points. Be sure any rise-time limitations of the oscilloscope are taken into account (refer to paragraph 2.6.3 for further rise-time details).

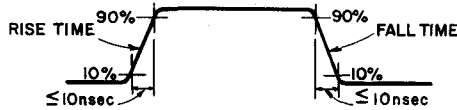

Overshoot and ringing. Not greater than 10% of amplitude.

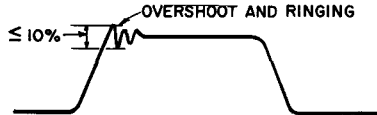

Jitter—oscilloscope limitation. The amount of jitter present in the oscilloscope must be taken into account when duration and period jitter are measured. Typical jitter for most delaying sweep oscilloscopes is 0.02% of the amount of delay. To determine actual jitter, connect a stable time-mark signal to the oscilloscope, set the oscilloscope for the amount of delay required, and measure any jitter that may be present. If the time-mark signal is stable, any jitter present is due to the oscilloscope.

Duration jitter. Less than or equal to 0.01% with the Type 1201 Power Supply; less than or equal to 0.03% with the Type 1203 Power Supply. Set the Type 1217-C controls as follows:

- ΔFcentered
- PRF..... 30 cps
- PULSE DURATION dial.....10
- PULSE DURATION RANGE.....1 to 10 msec
- AMPLITUDE.....1000 (fully clockwise)

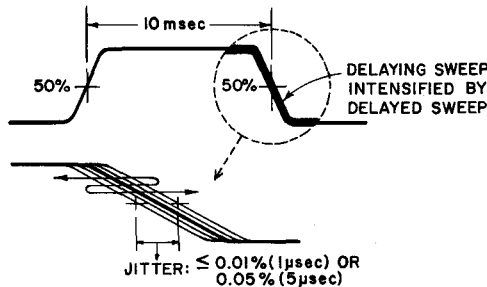

PRF jitter. Less than or equal to 0.01% with the Type 1201 Power Supply; less than or equal to 0.05% with the Type 1203 Power Supply. Set the Type 1217-C controls as follows:

- ΔFHIGH (fully clockwise)
- PRF..... 100 cps
- PULSE DURATION dial.....1
- PULSE DURATION RANGE.....1 to 10 μ sec
- AMPLITUDE.....1000 (fully clockwise)

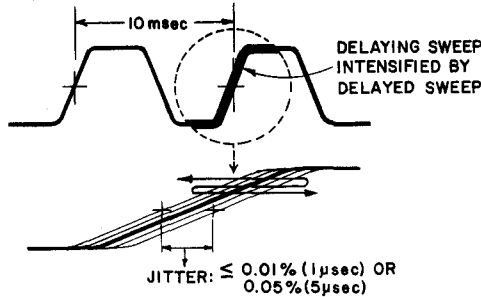

4.7.5 SYNC OUTPUT CHARACTERISTICS.

Setup. Connect the OUTPUT PULSE binding posts to the external trigger input of the oscilloscope and connect the appropriate SYNC binding post to the vertical input of the oscilloscope via a 10-megohm, 12-pf probe. Set the Type 1217-C controls as follows:

- ΔFHIGH (fully clockwise)
- PRF..... 1.2 Mc
- PULSE DURATION dial.....5
- PULSE DURATION RANGE.....0.1 to 1 μ sec
- AMPLITUDE.....1000 (fully clockwise)

±SYNC output. The characteristics and specifications for both the + and the - SYNC outputs are the same, except for polarity. Amplitude: Equal to or greater than 8 volts, peak-to-peak. Duration: Equal to or less than 0.2 μ sec.



DELAYED SYNC output. Amplitude: Equal to or greater than 8 volts, peak-to-peak. Duration: Equal to or less than 0.3 μ sec.

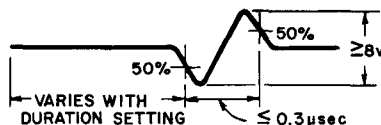



4.7.6 EXTERNAL DRIVE.

Setup. Connect a sine-wave generator to the EXT DRIVE binding posts. Set the generator for an output of 10 kc, 0.1v, rms. Set the Type 1217-C controls as follows:

- ΔF.....centered
- PRF..... EXT DRIVE
- PULSE DURATION dial.....1
- PULSE DURATION RANGE.....0.1 to 1 μsec
- AMPLITUDE.....1000 (fully clockwise)

R107 adjustment. Connect a 10-megohm probe from the oscilloscope to V102, pin 1. Adjust R107 for a symmetrical square wave.

2.2-Mc sensitivity. Set the generator for an output of 2.2 Mc, 0.5v, rms. Set the ΔF control for a triggered oscilloscope display. To check if the display is actually triggered, disconnect the sine-wave generator; if the display was triggered, the display will disappear. Reconnect the generator.

Trigger pulling. Vary the PULSE DURATION dial from 1 to 6; the pulse repetition frequency must remain 2.2 Mc.





Figure 4-3. Top rear interior view.

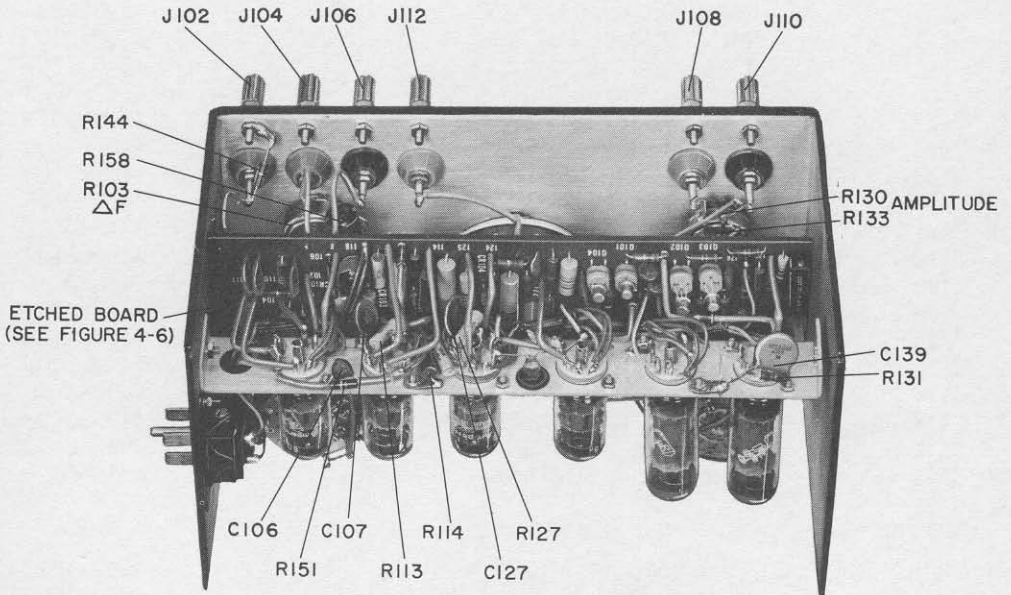

Figure 4-4. Bottom rear interior view.

PARTS LIST

REF NO.	DESCRIPTION	PART NO.
CAPACITORS		
C101	Ceramic, 47 pf $\pm 10\%$ NPO 500v	4410-0478
C102	Ceramic, 68 pf $\pm 10\%$ NPO 500v	4410-0688
C103	Ceramic, 0.01 μf $\pm 20\%$ 500v	4406-3100
C104	Ceramic, 0.01 μf $\pm 20\%$ 500v	4406-3100
C105	Ceramic, 0.01 μf $\pm 20\%$ 500v	4406-3100
C106	Ceramic, 100 pf $\pm 10\%$ 500v	4404-1108
C107	Ceramic, 22 pf $\pm 10\%$ NPO 500v	4410-0228
C108	Plastic, 1 μf $\pm 2\%$ 100v	4860-8002
C109	Plastic, 0.316 μf $\pm 2\%$ 200v	4860-7977
C110	Plastic, 0.0931 μf $\pm 1\%$ 100v	4860-7884
C111	Plastic, 0.0301 μf $\pm 2\%$ 200v	4860-7602
C112	Mica, 0.00909 μf $\pm 1\%$ 300v	4780-0096
C113	Mica, 0.00294 μf $\pm 2\%$ 500v	4780-0029
C114	Mica, 845 pf $\pm 2\%$ 300v	4690-4073
C115	Mica, 523 pf $\pm 1\%$ 300v	4690-4020
C116	Mica, 115 pf $\pm 2\%$ 500v	4650-0208
C117	Trimmer, 3 to 12 pf	4910-0600
C118	20 μf 250v	1130-0480
C119	20 μf 250v	1130-0480
C120	Ceramic, 20 pf $\pm 10\%$ 500v	4404-0208
C121	Ceramic, 0.001 μf $\pm 10\%$ 500v	4405-2108
C122	Mica, 61.9 pf $\pm 2\%$ 500v	4650-0110
C123	Mica, 0.001 μf $\pm 2\%$ 300v	4690-4200
C124	Mica, 0.01 μf $\pm 2\%$ 300v	4780-0300
C125	Plastic, 0.1 μf $\pm 2\%$ 200v	4860-8252
C126	Plastic, 1 μf $\pm 2\%$ 100v	4860-8002
C127	Ceramic, 82 pf $\pm 10\%$ NPO 500v	4410-0828
C128	Ceramic, 0.01 μf $\pm 80 -20\%$ 50v	4401-3100
C129	Ceramic, 0.01 μf $\pm 80 -20\%$ 50v	4401-3100
C130	Ceramic, 15 pf $\pm 5\%$ NPO 50v	4410-0155
C131	Ceramic, 33 pf $\pm 5\%$ N330 500v	4415-0335
C132	Ceramic, 0.01 μf $\pm 80 -20\%$ 50v	4401-3100
C133	Ceramic, 15 pf $\pm 5\%$ NPO 500v	4410-0155
C134	Ceramic, 15 pf $\pm 5\%$ NPO 500v	4410-0155
C135	Ceramic, 0.01 μf $\pm 20\%$ 500v	4406-3100
C136	Ceramic, 0.01 μf $\pm 20\%$ 500v	4404-2100
C138	Ceramic, 0.047 μf $\pm 20\%$ 250v	4408-3500
C139	Ceramic, 0.022 μf $\pm 20\%$ 500v	4407-3220
C140	Trimmer, 7 to 45 pf	4910-0100
C141	Trimmer, 1.5 to 7 pf	4910-0300
DIODES		
CR101	Type 1N625	6082-1012
CR103	Type 1N118A	6082-1006
CR104	Type 1N118A	6082-1006

PARTS LIST (continued)

REF NO.	DESCRIPTION	PART NO.
BINDING POSTS		
J101	Insulated	EXT DRIVE 4060-0100
J102	Uninsulated (ground)	EXT DRIVE 4060-1800
J103	Insulated	SYNC + 4060-0100
J104	Uninsulated (ground)	SYNC + 4060-1800
J105	Insulated	SYNC - 4060-0100
J106	Uninsulated (ground)	SYNC - 4060-1800
J107	Insulated	OUTPUT PULSE + 4060-0400
J108	Uninsulated (ground)	OUTPUT PULSE + 4060-1800
J109	Insulated	OUTPUT PULSE - 4060-0200
J110	Uninsulated (ground)	OUTPUT PULSE - 4060-1800
J111	Insulated	SYNC DELAYED 4060-0100
J112	Uninsulated (ground)	SYNC DELAYED 4060-1800
CHOKES		
L101	Metal, 120 μh $\pm 10\%$	4300-3600
L102	Metal, 82 μh $\pm 10\%$	4300-3400
L103	Metal, 150 μh $\pm 10\%$	4300-3810
L104	Metal, 27 μh $\pm 10\%$	4300-2800
L105	Metal, 56 μh $\pm 10\%$	4300-3200
L106	Metal, 1.8 μh $\pm 10\%$	4300-1100
L107	Metal, 1.8 μh $\pm 10\%$	4300-1100
PLUGS		
PL101	Plug, power supply	4220-0401
TRANSISTORS		
Q101	Type 2N708	8210-3089
Q102	Type 2N708	8210-3089
Q103	Type 2N708	8210-3089
Q104	Type 2N708	8210-3089
RESISTORS		
R101	Composition, 33 k Ω $\pm 5\%$ 1/2w	6100-3335
R102	Film, 31.6 k Ω $\pm 1\%$ 1/2w	6450-2316
R103	Potentiometer, composition 250 k Ω $\pm 10\%$ ΔF	6048-4259
R104	Film, 32.4 k Ω $\pm 1\%$ 1/4w	6350-2324
R105	Composition, 3 k Ω $\pm 5\%$ 1/2w	6100-2305
R106	Composition, 2 M Ω $\pm 5\%$ 1/2w	6100-5205
R107	Potentiometer, wire-wound 500 Ω $\pm 10\%$	6057-1509
R108	Film, 52.3 k Ω $\pm 1\%$ 1/2w	6450-2523
R109	Composition, 1 k Ω $\pm 5\%$ 1/2w	6100-2105
R110	Composition, 1 k Ω $\pm 5\%$ 1/2w	6100-2105
R111	Composition, 110 k Ω $\pm 5\%$ 1/2w	6100-4115
R112	Composition, 3 k Ω $\pm 5\%$ 1 w	6110-2305



PARTS LIST (continued)

REF NO.	DESCRIPTION	PART NO.
R113	Film, 100 k Ω $\pm 1\%$ 1/4w	6350-3100
R114	Composition, 3.3 k Ω $\pm 5\%$ 1 w	6110-2335
R115	Film, 51.1 k Ω $\pm 1\%$ 1/4w	6350-2511
R116	Film, 150 k Ω $\pm 1\%$ 1/4w	6350-3150
R117	Power, 7.5 k Ω $\pm 5\%$ 3 w	6680-2755
R118	Composition, 68 k Ω $\pm 5\%$ 1/2w	6100-3685
R119	Film, 270 k Ω $\pm 1\%$ 1/4w	6350-3270
R120	Film, 2.74 M Ω $\pm 1\%$ 2 w	6590-4274
R121	Composition, 56 Ω $\pm 5\%$ 1/2w	6100-0565
R122	Composition, 1.5 k Ω $\pm 5\%$ 1/2w	6100-2155
R123	Composition, 1.2 k Ω $\pm 5\%$ 1/2w	6100-2125
R124	Composition, 1 k Ω $\pm 5\%$ 1/2w	6100-2105
R125	Potentiometer, 5 k Ω PULSE DURATION	0975-4050
R126	Composition, 1.5 k Ω $\pm 5\%$ 1/2w	6100-2155
R127	Film, 191 k Ω $\pm 1\%$ 1/4w	6350-3191
R128	Composition, 130 k Ω $\pm 5\%$ 1/2w	6100-1135
R129	Film, 100 k Ω $\pm 1\%$ 1/4w	6350-3100
R130	Potentiometer, 1 k Ω $\pm 10\%$ + AMPLITUDE	*1217-0400
R131	Composition, 10 M Ω $\pm 5\%$ 1/2w	6100-6105
R132	Composition, 150 k Ω $\pm 5\%$ 1/2w	6100-1155
R133	Potentiometer, 1 k Ω $\pm 10\%$ - AMPLITUDE	*1217-0400
R134	Composition, 100 k Ω $\pm 5\%$ 1/2w	6100-4105
R135	Composition, 100 k Ω $\pm 5\%$ 1/2w	6100-4105
R136	Composition, 330 Ω $\pm 5\%$ 1/2w	6100-1335
R137	Composition, 150 Ω $\pm 5\%$ 1/2w	6100-1155
R138	Composition, 150 Ω $\pm 5\%$ 1/2w	6100-1155
R139	Composition, 6.8 k Ω $\pm 5\%$ 1/2w	6100-2685
R140	Composition, 6.8 k Ω $\pm 5\%$ 1/2w	6100-2685
R141	Composition, 150 Ω $\pm 5\%$ 1/2w	6100-1155
R142	Composition, 200 Ω $\pm 5\%$ 1/2w	6100-1205
R143	Composition, 2 k Ω $\pm 5\%$ 1/2w	6100-2205
R144	Composition, 1 M Ω $\pm 5\%$ 1/2w	6100-5105
R145	Composition, 3.6 k Ω $\pm 5\%$ 1 w	6110-2365
R146	Composition, 5.6 k Ω $\pm 5\%$ 1/2w	6100-2565
R147	Potentiometer, wire-wound 100 Ω $\pm 10\%$	6057-1109
R148	Composition, 30 Ω $\pm 5\%$ 1/2w	6100-0305
R149	Composition, 30 Ω $\pm 5\%$ 1/2w	6100-0305
R150	Composition, 10 M Ω $\pm 5\%$ 1/2w	6100-6105
R151	Composition, 100 k Ω $\pm 5\%$ 1/2w	6100-4105
R152	Composition, 330 k Ω $\pm 5\%$ 1/2w	6100-1335
R153	Composition, 150 Ω $\pm 5\%$ 1/2w	6100-1155
R154	Composition, 15 Ω $\pm 5\%$ 1/2w	6100-0155
R155	Composition, 15 Ω $\pm 5\%$ 1/2w	6100-0155
R156	Composition, 10 k Ω $\pm 5\%$ 1/2w	6100-3105
R157	Composition, 10 k Ω $\pm 5\%$ 1/2w	6100-3105
R158	Potentiometer, wire-wound 10 k Ω $\pm 10\%$	6057-3109

*1217-0400 is a dual potentiometer consisting of both R130 and R133.



PARTS LIST (continued)

REF NO.	DESCRIPTION	PART NO.
---------	-------------	----------

SWITCHES

S101	Rotary wafer	BRF 7890-3670
S102	Rotary wafer	PULSE DURATION 7890-3740

TUBES

V101	Type 6DJ8	8380-9911
V102	Type 6DJ8	8380-9911
V103	Type 6DJ8	8380-9911
V104	Type 6922	8380-9912
V105	Type 6CW5	8380-9910
V106	Type 6CW5	8380-9910
V107	Type NE-96	8390-Q960

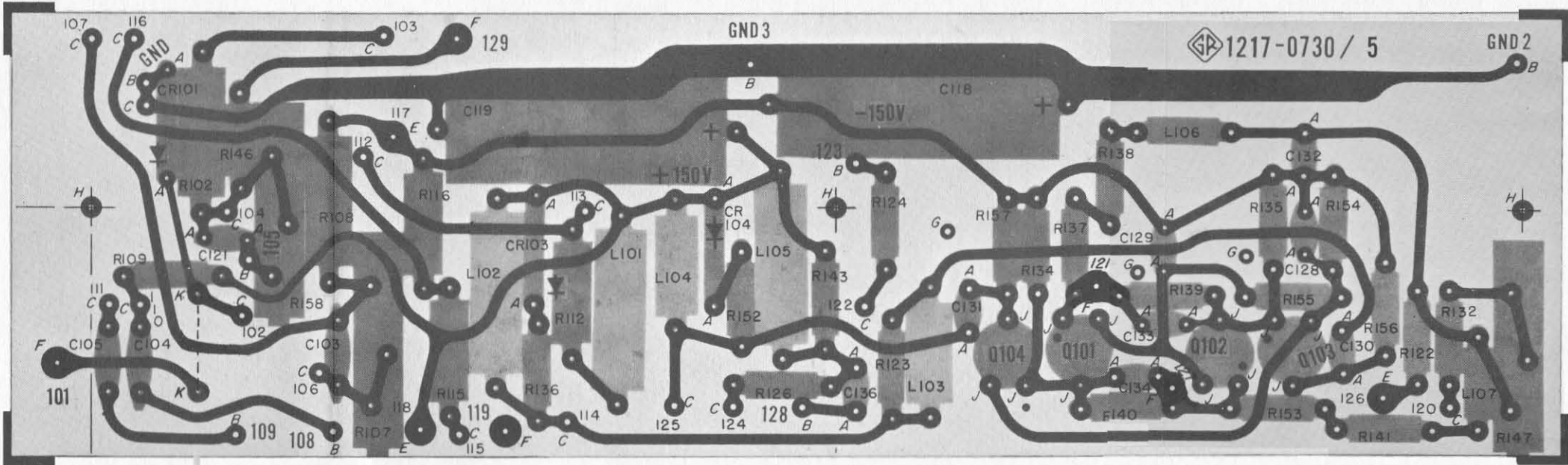
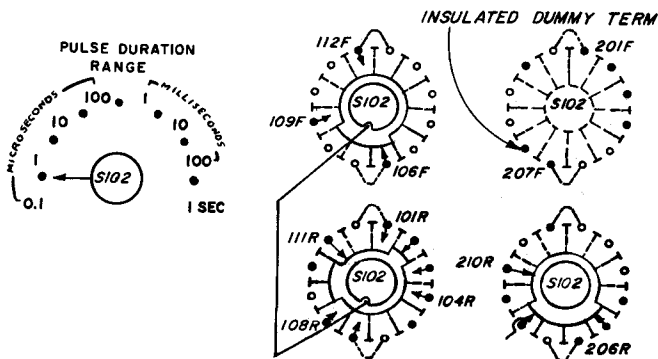
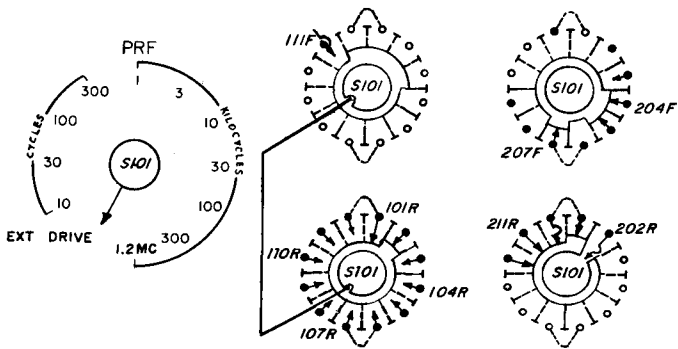
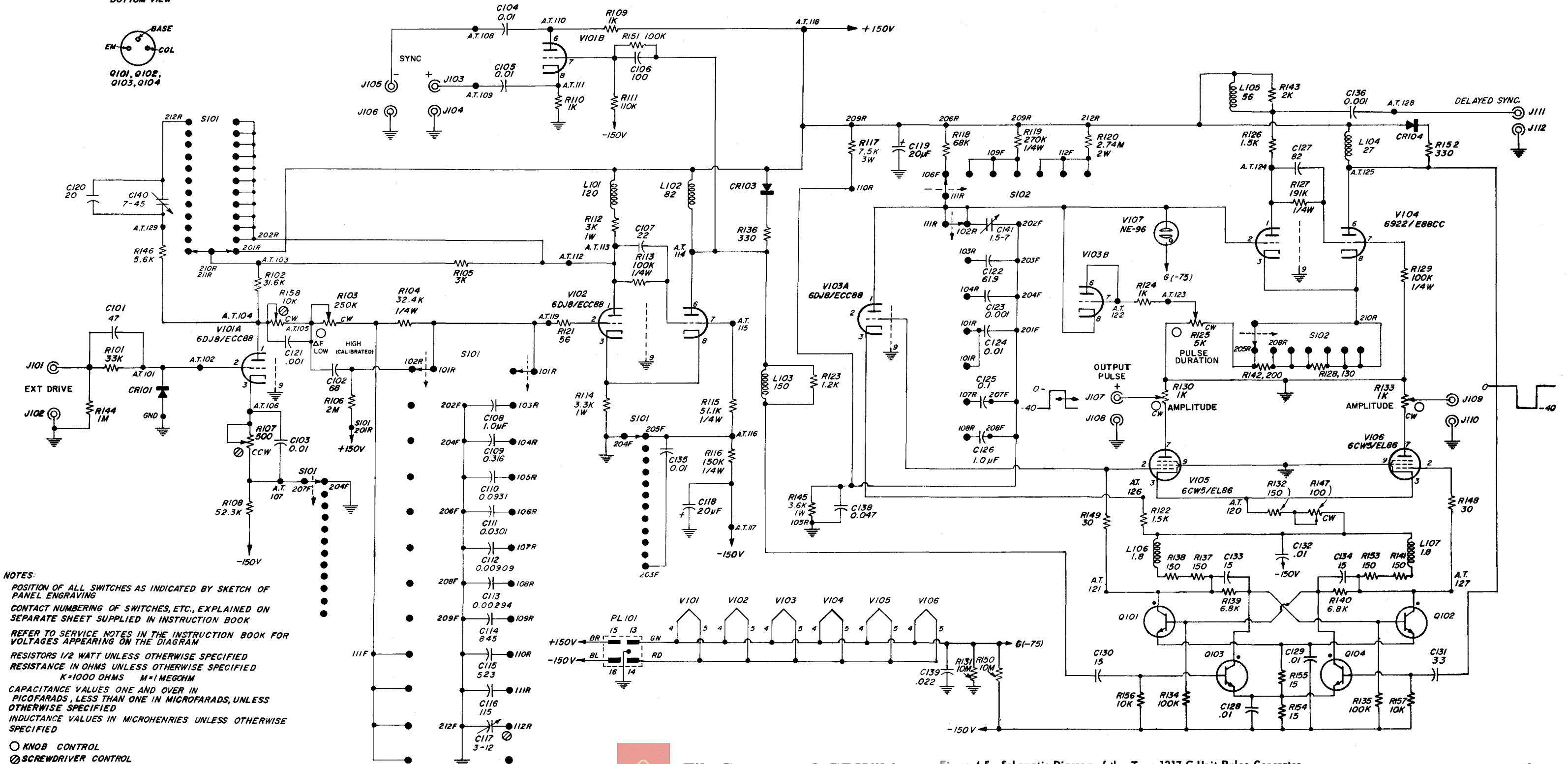
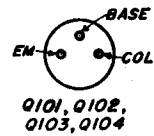

Figure 4-6. PCB layout. File Courtesy of GRWiki.org



Rotary switch sections are shown as viewed from the panel end of the shaft. The first digit of the contact number refers to the section. The section nearest the panel is 1, the next section back is 2, etc. The next two digits refer to the contact. Contact 01 is the first position clockwise from a strut screw (usually the screw above the locating key), and the other contacts are numbered sequentially (02, 03, 04, etc), proceeding clockwise around the section. A suffix F or R indicates that the contact is on the front or rear of the section, respectively.

BOTTOM VIEW



NOTES:

- POSITION OF ALL SWITCHES AS INDICATED BY SKETCH OF PANEL ENGRAVING
- CONTACT NUMBERING OF SWITCHES, ETC., EXPLAINED ON SEPARATE SHEET SUPPLIED IN INSTRUCTION BOOK
- REFER TO SERVICE NOTES IN THE INSTRUCTION BOOK FOR VOLTAGES APPEARING ON THE DIAGRAM
- RESISTORS 1/2 WATT UNLESS OTHERWISE SPECIFIED
- RESISTANCE IN OHMS UNLESS OTHERWISE SPECIFIED
- K=1000 OHMS M=1 MEGOHM
- CAPACITANCE VALUES ONE AND OVER IN PICO FARADS, LESS THAN ONE IN MICROFARADS, UNLESS OTHERWISE SPECIFIED
- INDUCTANCE VALUES IN MICROHENRIES UNLESS OTHERWISE SPECIFIED

- KNOB CONTROL
- ⊗ SCREWDRIVER CONTROL



GENERAL RADIO COMPANY

WEST CONCORD, MASSACHUSETTS 01781

617 369-4400

617 646-7400

SALES ENGINEERING OFFICES

NEW ENGLAND *

22 Baker Avenue
West Concord, Massachusetts 01781
Telephone 617 646-0550

METROPOLITAN NEW YORK *

Broad Avenue at Linden
Ridgefield, New Jersey 07657
Telephone N.Y. 212 964-2722
N.J. 201 943-3140

SYRACUSE

Pickard Building
East Molloy Road
Syracuse, New York 13211
Telephone 315 454-9323

PHILADELPHIA

Fort Washington Industrial Park
Fort Washington, Pennsylvania 19034
Telephone 215 646-8030

WASHINGTON * AND BALTIMORE

11420 Rockville Pike
Rockville, Maryland 20852
Telephone 301 946-1600

ORLANDO

113 East Colonial Drive
Orlando, Florida 32801
Telephone 305 425-4671

* Repair services are available
at these district offices.

CHICAGO *

6605 West North Avenue
Oak Park, Illinois 60302
Telephone 312 848-9400

CLEVELAND

5579 Pearl Road
Cleveland, Ohio 44129
Telephone 216 886-0150

LOS ANGELES *

1000 North Seward Street
Los Angeles, California 90038
Telephone 213 469-6201

SAN FRANCISCO

1186 Los Altos Avenue
Los Altos, California 94022
Telephone 415 948-8233

DALLAS *

2600 Stemmons Freeway, Suite 210
Dallas, Texas 75207
Telephone 214 637-2240

TORONTO *

99 Floral Parkway
Toronto 15, Ontario, Canada
Telephone 416 247-2171

MONTREAL

1255 Laird Boulevard
Town of Mount Royal, Quebec, Canada
Telephone 514 737-3673

General Radio Company (Overseas), 8008 Zurich, Switzerland
General Radio Company (U.K.) Limited, Bourne End, Buckinghamshire, England
Representatives in Principal Overseas Countries

